

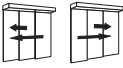

 WN 059437 45532
 01 02/09

LH ^{max.} : 3 000 mm			
	ES 200 EASY	ES 200	ES 200 2D
	m = 2 x 50 kg LW: 800 - 2400 mm	m = 2 x 75 kg LW: 800 - 2400 mm	m = 2 x 75 kg LW: 1000 - 2400 mm
	m = 4 x 43 kg LW: 1400 - 4000 mm	m = 4 x 75 kg LW: 1400 - 4000 mm	m = 4 x 65 kg LW: 1400 - 4000 mm

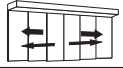

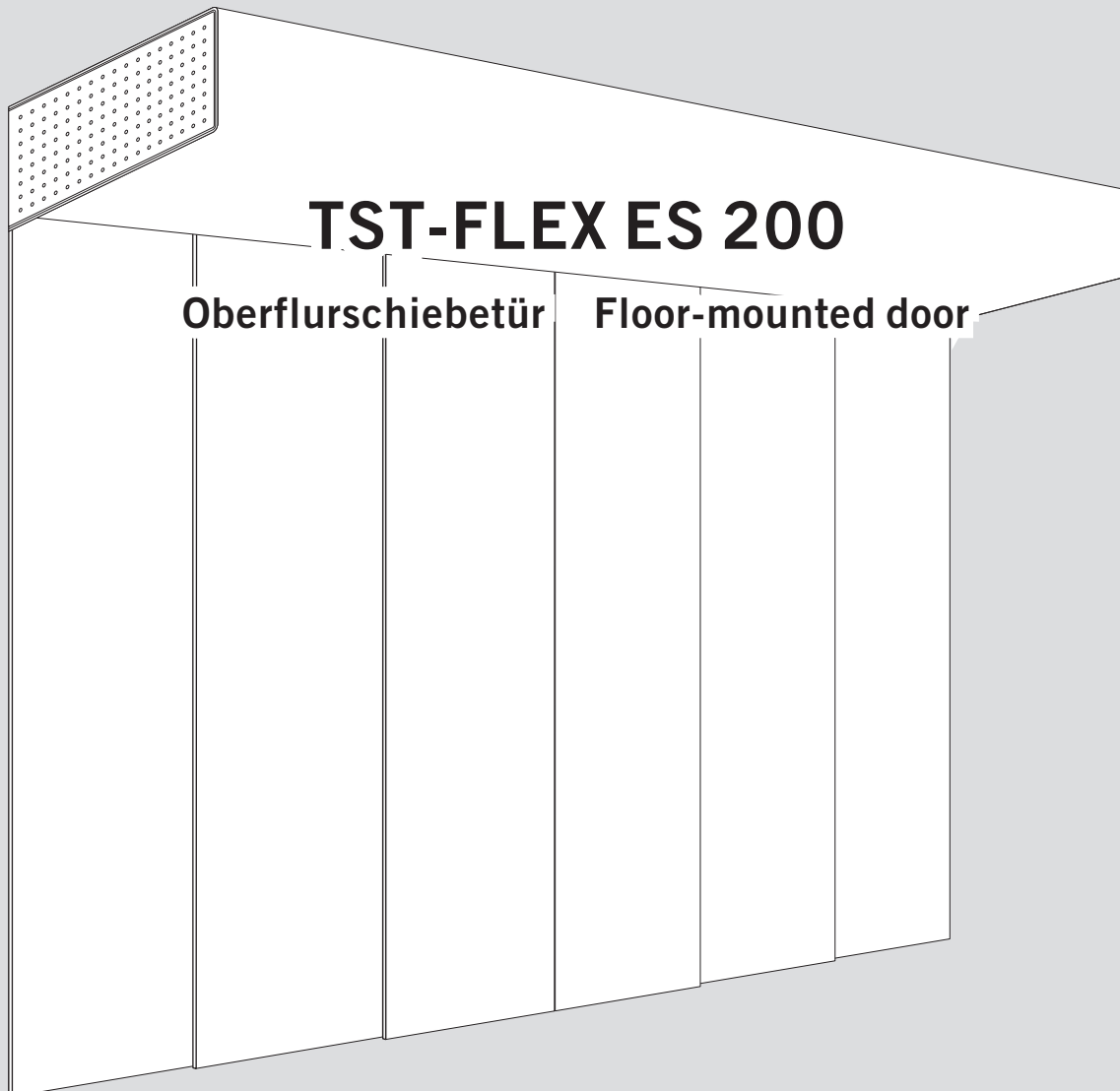

WN 069437 45532
02 02/09

Inhaltsverzeichnis

02.2009

	Seite
Inhaltsverzeichnis	02
Übersicht Schnittzeichnungen	03
Fahrflügel Schnellläufer	
Benötigte Profile und Zubehör	04 - 05
Übersichtszeichnung des Fahrflügels	06
Bearbeitungszeichnungen der Profile	07
Fahrflügel Langsamläufer	
Benötigte Profile und Zubehör	08 - 09
Übersichtszeichnung des Fahrflügels	10
Bearbeitungszeichnungen der Profile	11
Seitenteil	
Benötigte Profile und Zubehör	12 - 13
Übersichtszeichnung des Seitenteils	14
Bearbeitungszeichnungen der Profile	15 - 16
Wandanbindung der Anlage ohne Seitenteil	
Benötigte Profile und Zubehör	17/18
Übersichtszeichnung der Anbindung	17/18
Bearbeitungszeichnungen der Profile	17/19
Oberlicht	
Benötigte Profile und Zubehör	20 - 21
Übersichtszeichnung des Oberlichts	22
Bearbeitungszeichnungen der Profile	23

Contents

02.2009

	Side
Contents	02
Overview cutaway	03
Moving leaf fast	
Profiles and accessories which are required	04 - 05
Overview drawing of the moving leaf	06
Detail drawings of the profiles	07
Moving leaf slow	
Profiles and accessories which are required	08 - 09
Overview drawing of the moving leaf	10
Detail drawings of the profiles	11
Side panel	
Profiles and accessories which are required	12 - 13
Overview drawing of the side panel	14
Detail drawings of the profiles	15 - 16
Connection to the wall without side panel	
Profiles and accessories which are required	17/18
Overview drawing of the Connection to the wall	17/18
Detail drawings of the profiles	17/19
Transom light	
Profiles and accessories which are required	20 - 21
Overview drawing of the transom light	22
Detail drawings of the profiles	23



WN 059437 45532
03 02/09

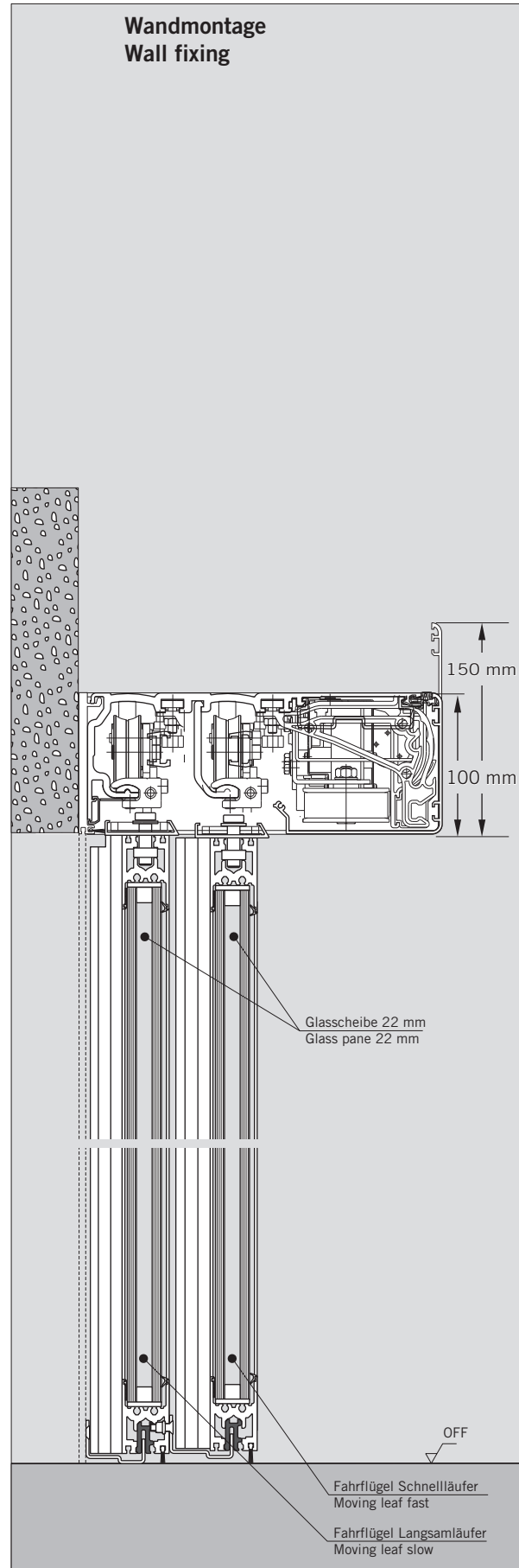
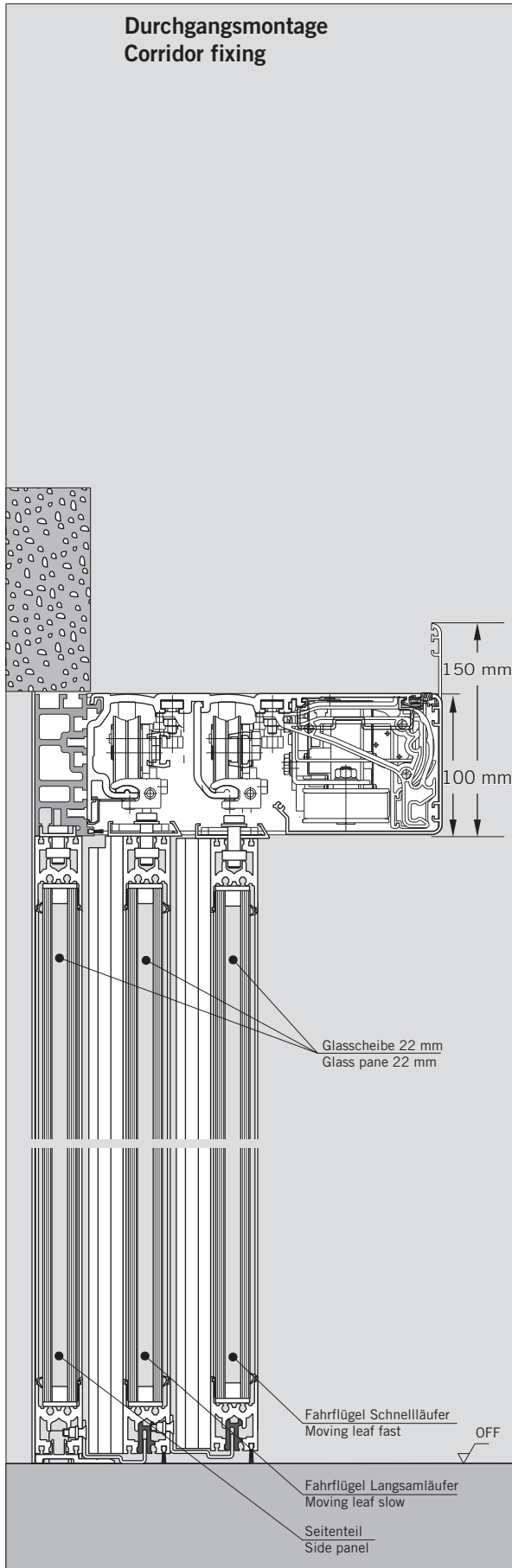



WN 059437 45532
04 02/09

A		B		St. pc.
Profile/Zubehör Profils/accessories	Artikelnummer Article-number	Bezeichnung Name	Zuschnittsformel Cutting Formula	
	325 408-XX-1-20 01 - 6250mm roh / mill finish 02 - 6250mm E6 / CO 06 - 4250mm roh / mill finish 07 - 4250mm E6 / CO	Horizontalprofil horizontal profile	A $L = \frac{LW}{4} - 39$ B $L = \frac{LW}{2} - 39$	2
 PVC schwarz	325 411-XX-1-20 02 - 2500mm 03 - 3200mm	Seitendichtung side seal	$L = LH - 10$	1
	325 409-XX-1-20 01 - 5100mm roh / mill finish 02 - 5100mm E6 / CO	Vertikalprofil vertical profile	$L = LH - 10$	2
 PVC schwarz	325 412-XX-1-20 01 - 2500mm 02 - 3200mm	Mitteldichtung central seal	$L = LH - 10$	1
	255 069-XX-1-20 01 - 6250mm roh / mill finish 02 - 6250mm E6 / CO	Justierbügelprofil adjustable bracket profile	A $L = \frac{LW}{4} + 37$ B $L = \frac{LW}{2} + 37$	1
	325 424-01-1-20	Gummidichtung rubber seal	GB GH	2
	325 137-02-1-20	Gummidichtung rubber seal	GB GH	2
	050 121-12-3-32	Bürste brush	A $L = \frac{LW}{4} + 24$ B $L = \frac{LW}{2} + 24$	1
	325 082-21-1-20	Gleiterprofil slide profile	A $L = \frac{LW}{4} + 24$ B $L = \frac{LW}{2} + 24$	1
		Glasscheibe glass pane	A $GB = \frac{LW}{4} - 11$ $GH = LH - 76$ B $GB = \frac{LW}{2} - 11$ $GH = LH - 76$	1

pro Fahrflügel Schnellläufer
per moving leaf fast

 WN 059437 45532
 05 02/09

A		B		St. pc.
Profile/Zubehör Profils/accessories	Artikelnummer Article-number	Bezeichnung Name	Zuschnittsformel Cutting Formula	
pro Fahrflügel Schnellläufer per moving leaf fast				
	Montageset – Fahrflügel fixing set – moving leaf 4400320	FLEX-Eckverbinder corner join		2
		Halteklammer retaining clip		2
		Gegenhalteplatte retaining plate		2
		Verdrehsicherung anti twist protection		2

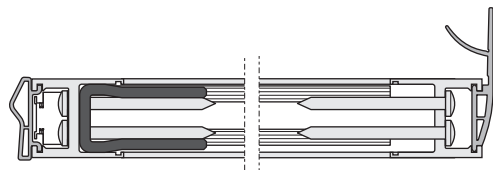
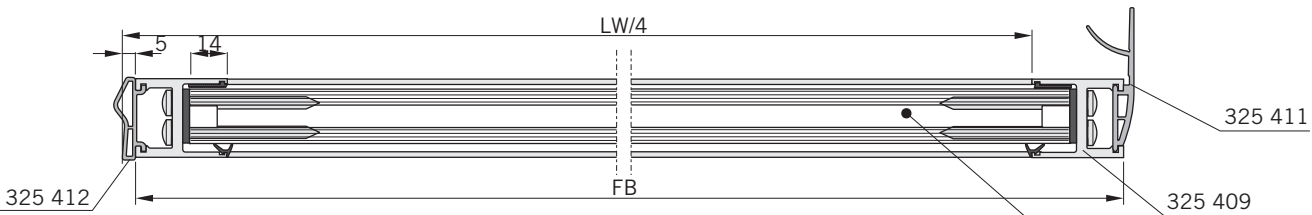
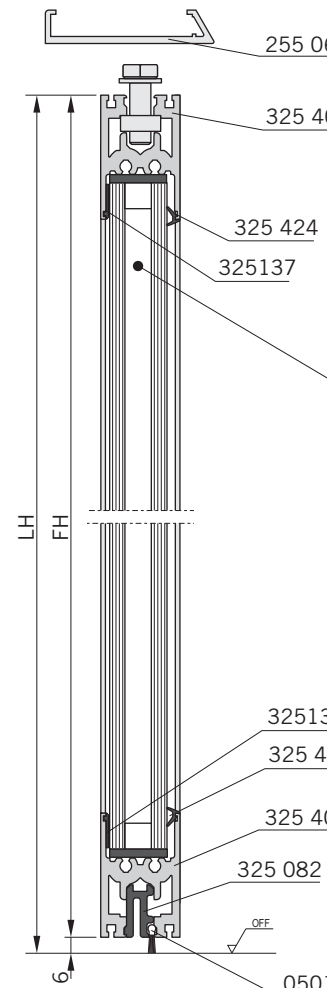
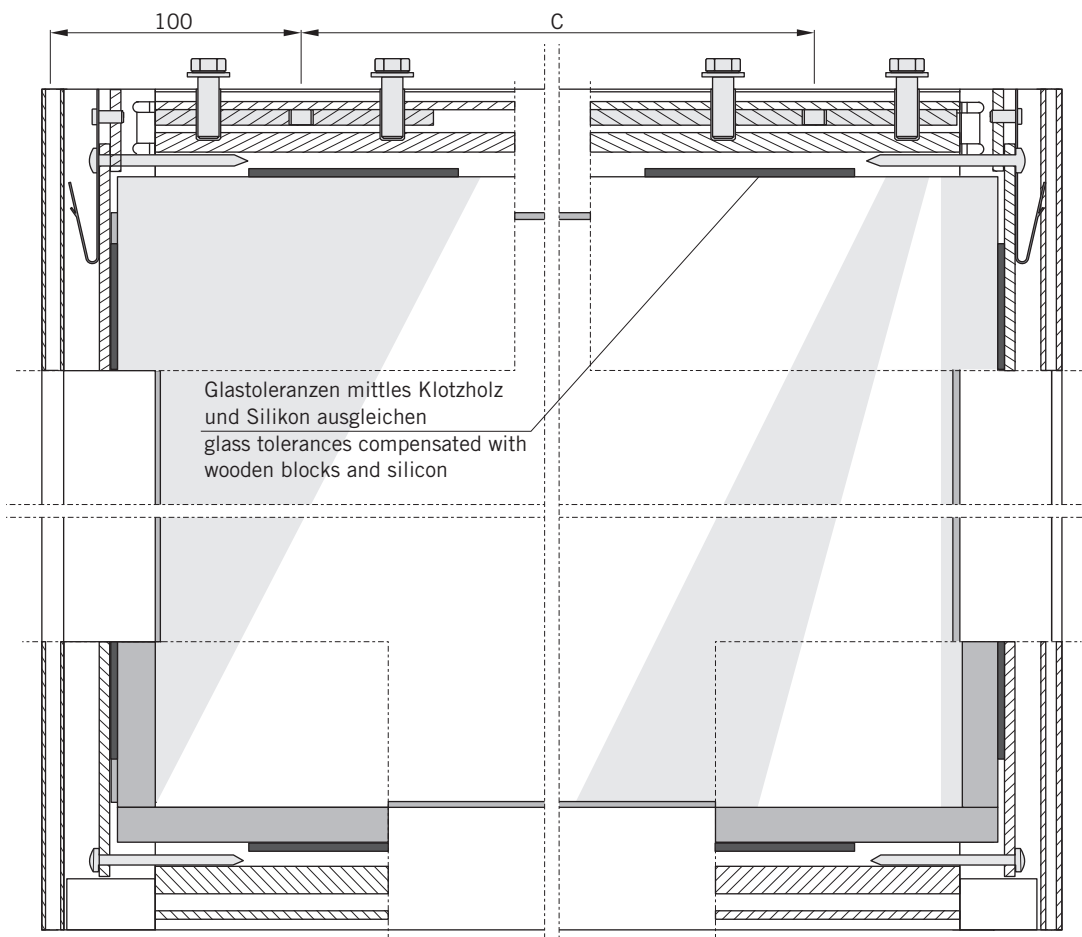

Glasscheibe 22 mm
Glass pane 22 mm



WN 059437 45532
07 02/09

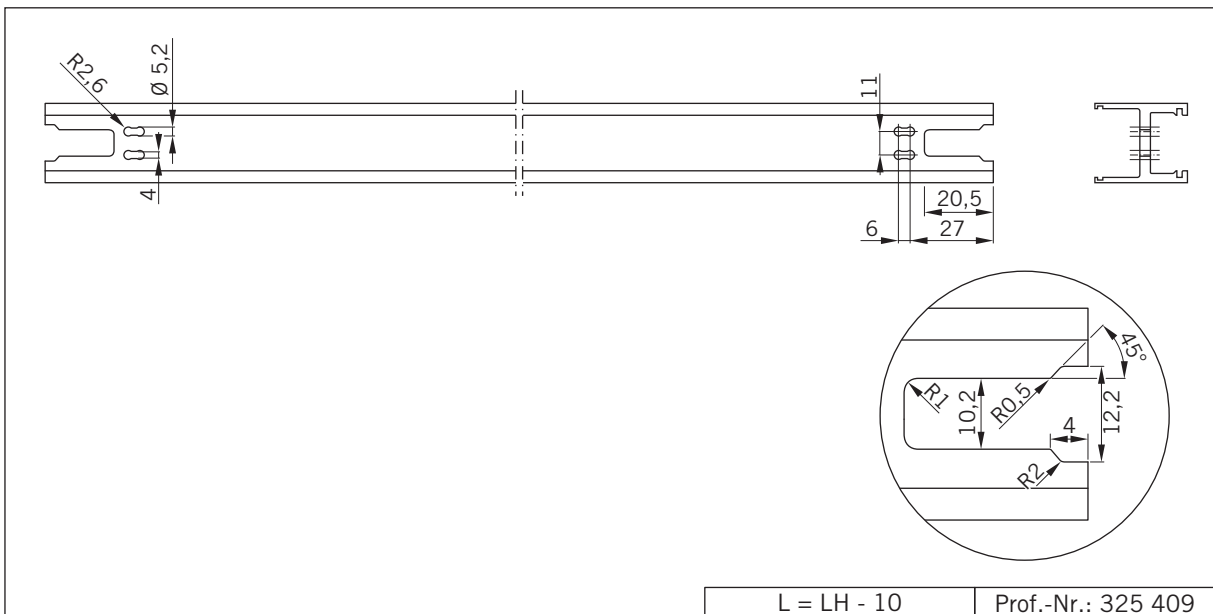
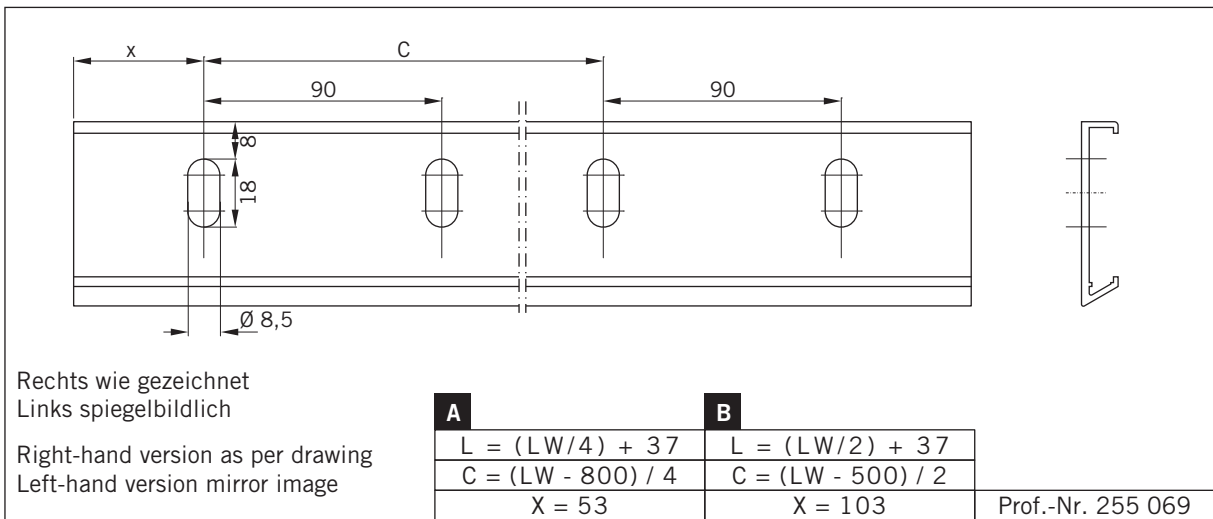
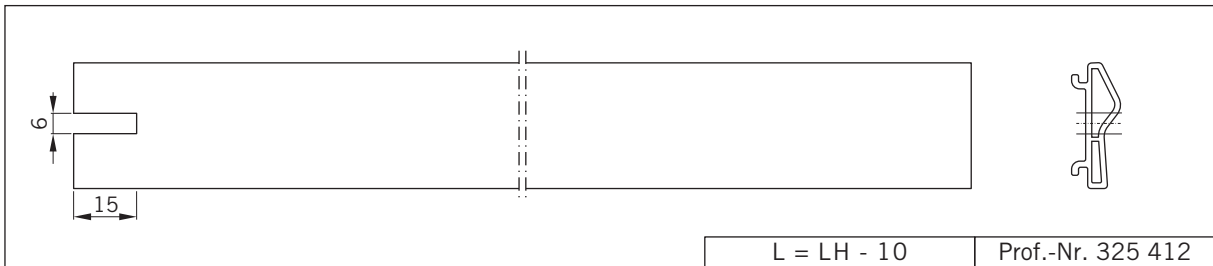
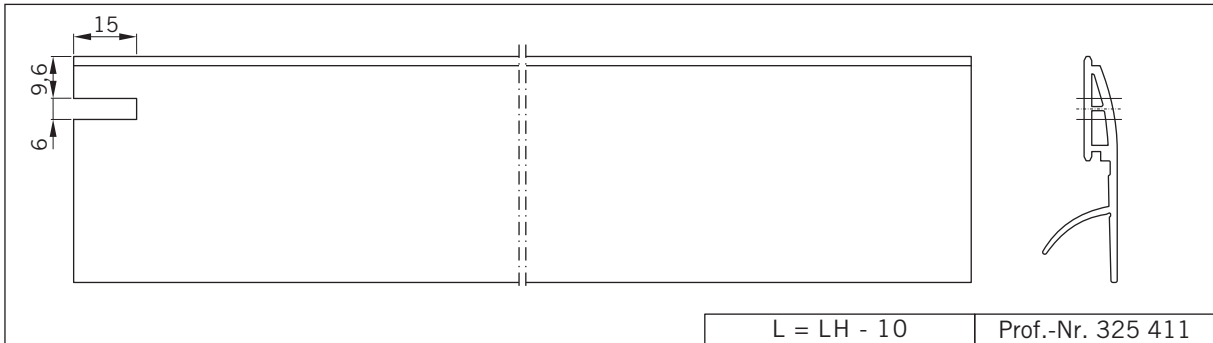



 WN 059437 45532
 08 02/09

A		B		St. pc.
Profile/Zubehör Profils/accessories	Artikelnummer Article-number	Bezeichnung Name	Zuschnittsformel Cutting Formula	
	325 408-XX-1-20 01 - 6250mm roh / mill finish 02 - 6250mm E6 / CO 06 - 4250mm roh / mill finish 07 - 4250mm E6 / CO	Horizontalprofil horizontal profile	A $L = \frac{LW}{4} - 39$ B $L = \frac{LW}{2} - 39$	2
 PVC schwarz	325 411-XX-1-20 02 - 2500mm 03 - 3200mm	Seitendichtung side seal	$L = LH - 6$	1
	325 409-XX-1-20 01 - 5100mm roh / mill finish 02 - 5100mm E6 / CO	Vertikalprofil vertical profile	$L = LH - 6$	2
	325 418-XX-1-20 01 - 5100 mm roh / mill finish 02 - 5100 mm E6 / CO	Seitendichtung side seal profile	$L = LH - 6$	1
	255 069-XX-1-20 01 - 6250mm roh / mill finish 02 - 6250mm E6 / CO	Justierbügelprofil adjustable bracket profile	A $L = \frac{LW}{4} + 39$ B $L = \frac{LW}{2} + 39$	1
	325 424-01-1-20	Gummidichtung rubber seal	GB GH	2
	325 137-02-1-20	Gummidichtung rubber seal	GB GH	2
	050 107-12-3-32	Bürste brush	A $L = \frac{LW}{4} + 27$ B $L = \frac{LW}{2} + 27$	1
	325 082-21-1-20	Gleiterprofil slide profile	A $L = \frac{LW}{4} + 27$ B $L = \frac{LW}{2} + 27$	1
		Glasscheibe glass pane	A $GB = \frac{LW}{4} - 11$ $GH = LH - 72$ B $GB = \frac{LW}{2} - 11$ $GH = LH - 72$	1

 pro Fahrflügel Langsamläufer
 per moving leaf slow

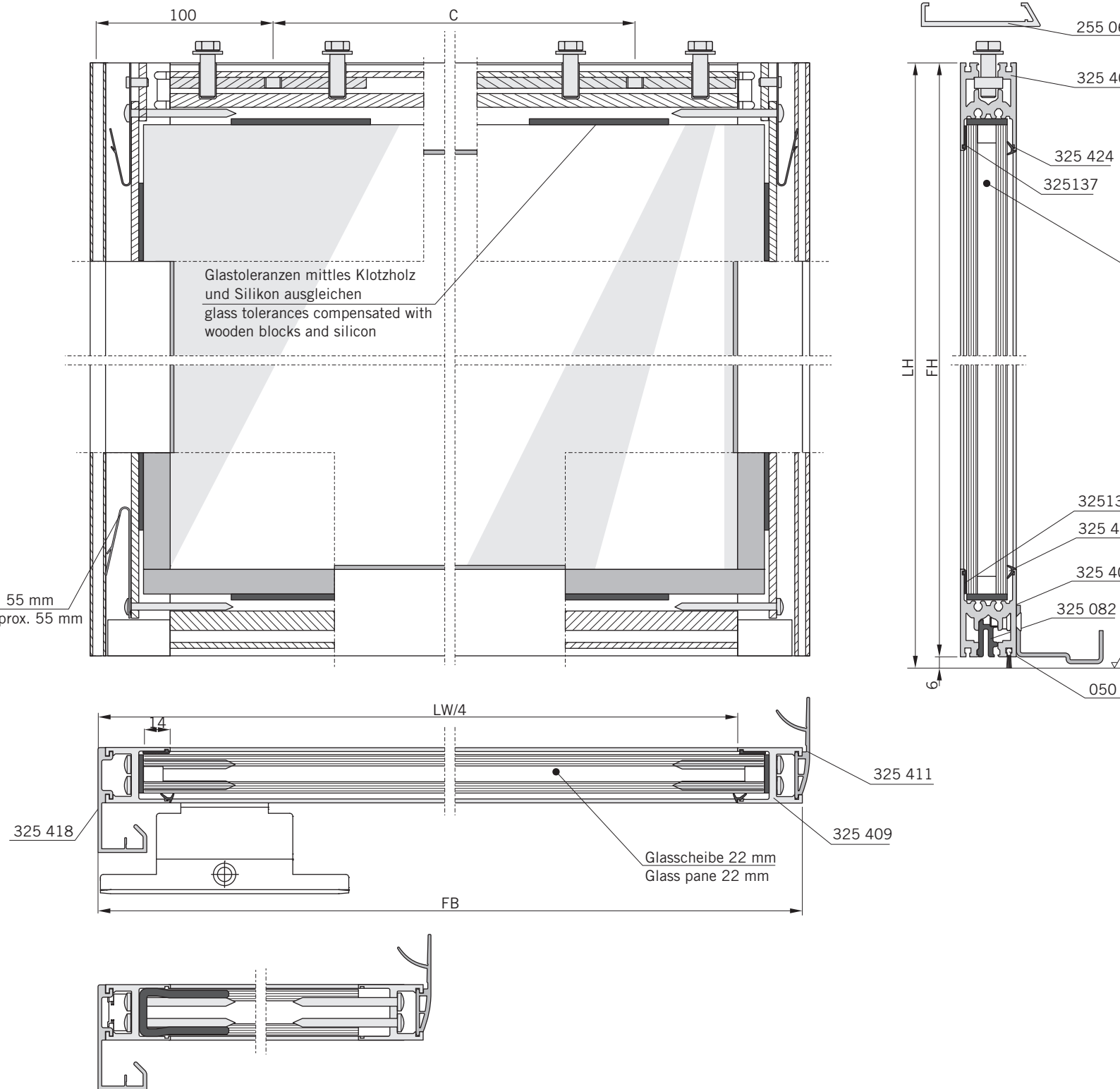

 WN 059437 45532
 09 02/09

A		B		St. pc.
Profile/Zubehör Profils/accessories	Artikelnummer Article-number	Bezeichnung Name	Zuschnittsformel Cutting Formula	pro Fahrflügel Langsamläufer per moving leaf slow
 	Montageset – Fahrflügel fixing set – moving leaf 4400320	FLEX-Eckverbinder corner join		2
		Halteklammer retaining clip		3
		Gegenhalteplatte retaining plate		2
		Verdrehsicherung anti twist protection		2
		Führungswinkel U-Form guide bracket U-shape		1



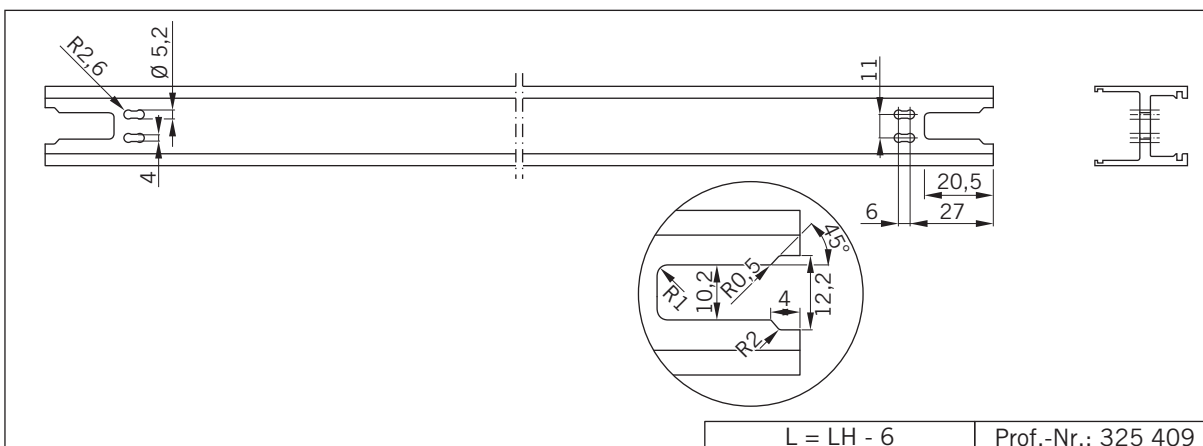
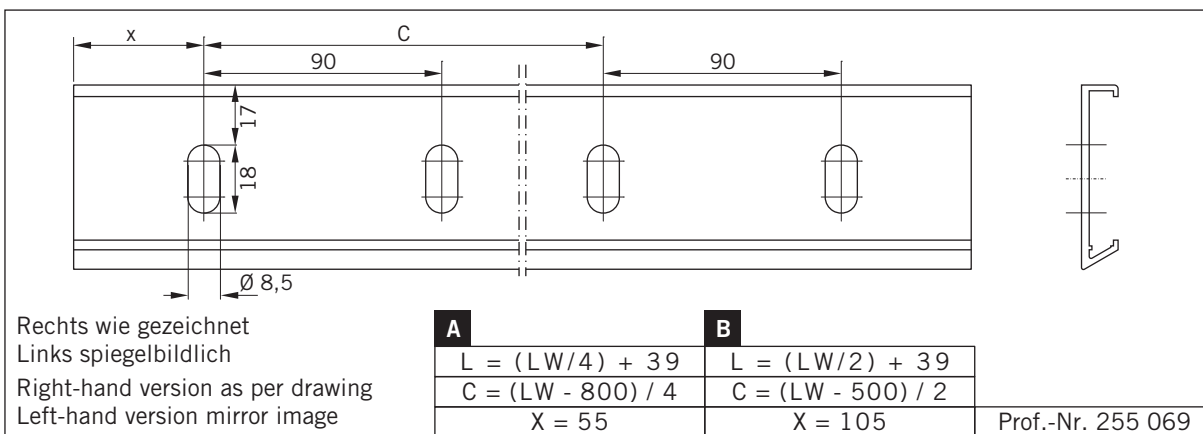
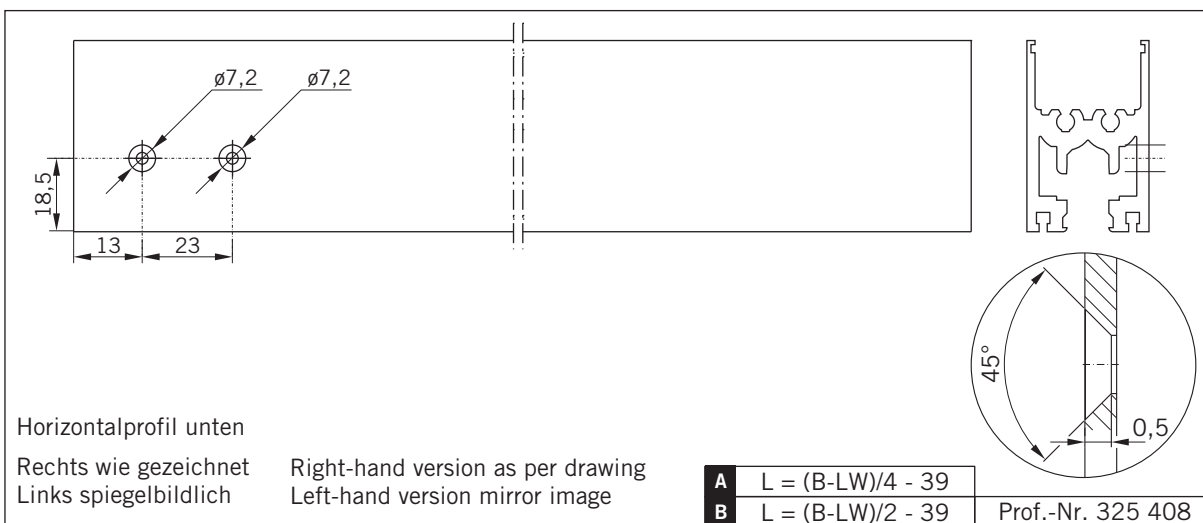
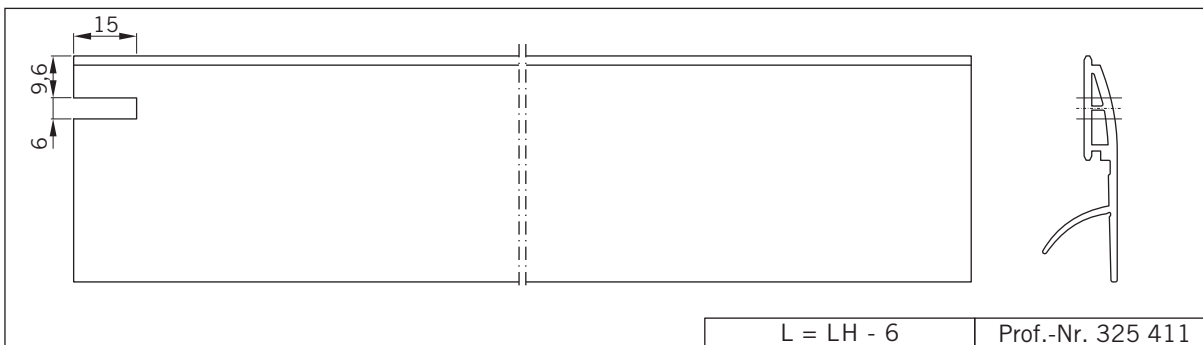

WN 059437 45532
11 02/09



 WN 069437 45632
12 02/09

A		B		St. pc.
Profil/Zubehör Profils/accessories	Artikelnummer Article-number	Bezeichnung Name	Zuschnittsformel Cutting Formula	pro Seitenteil per side panel
	325 408-XX-1-20 01 - 6250mm roh / mill finish 02 - 6250mm E6 / CO 06 - 4250mm roh / mill finish 07 - 4250mm E6 / CO	Horizontalprofil horizontal profile	A $L = \frac{(B-LW)}{2} - 89$	2
			B $L = (B-LW) - 89$	
	325 409-XX-1-20 01 - 5100 mm roh / mill finish 02 - 5100 mm E6 / CO	Vertikalprofil vertical profile	$L = LH$	2
	325 219-XX-1-20 01 - 5100 mm roh / mill finish 02 - 5100 mm E6 / CO	U-Profil U-profile	$L = LH$	1
	255 088-00-1-20	Ausnehmung nur bei LM-Träger 100mm Only LM-girder 100mm cut out	$L = LH + 100$	
	325 418-XX-1-20 01 - 5100 mm roh / mill finish 02 - 5100 mm E6 / CO	Seitendichtung side seal profile	$L = LH$	1
	325 413-XX-1-20 01 - 6250mm roh / mill finish 02 - 6250mm E6 / CO 06 - 4250mm roh / mill finish 07 - 4250mm E6 / CO	Bodenschiene ground rail track	A $L = \frac{(B-LW)}{2} - 89$	1
			B $L = (B-LW) - 89$	
	325 424-01-1-20	Gummidichtung rubber seal	GB GH	2
	325 137-02-1-20	Gummidichtung rubber seal	GB GH	2
		Glasscheibe glass pane	A $GB = \frac{(B-LW)}{2} - 61$ GH = LH - 72	1
			B $GB = (B-LW) - 61$ GH = LH - 72	



WN 059437 45532
02/09

A		B		St. pc.
Profile/Zubehör Profils/accessories	Artikelnummer Article-number	Bezeichnung Name	Zuschnittsformel Cutting Formula	St. pc.
	Montageset – Seitenteil fixing set – side panel 4400330	U-Füllstück U-filler		2
		Halteklammer retaining clip		2
		Gegenhalteplatte retaining plate		2
		Verdrehsicherung anti twist protection		4
		Führungswinkel U-Form guide bracket U-shape		1

pro Seitenteil
per side panel

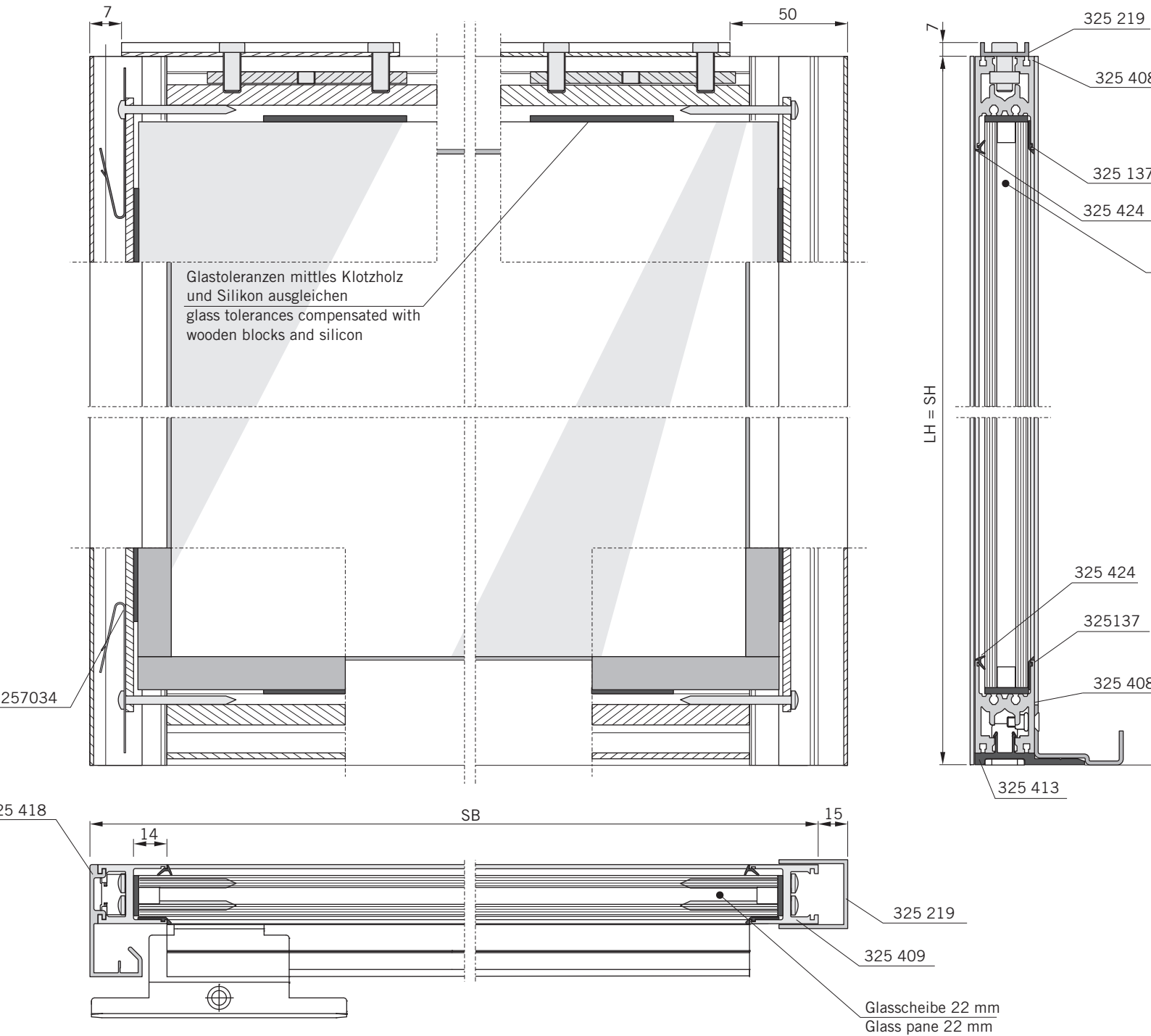



WN 069437 45632
15 02/09

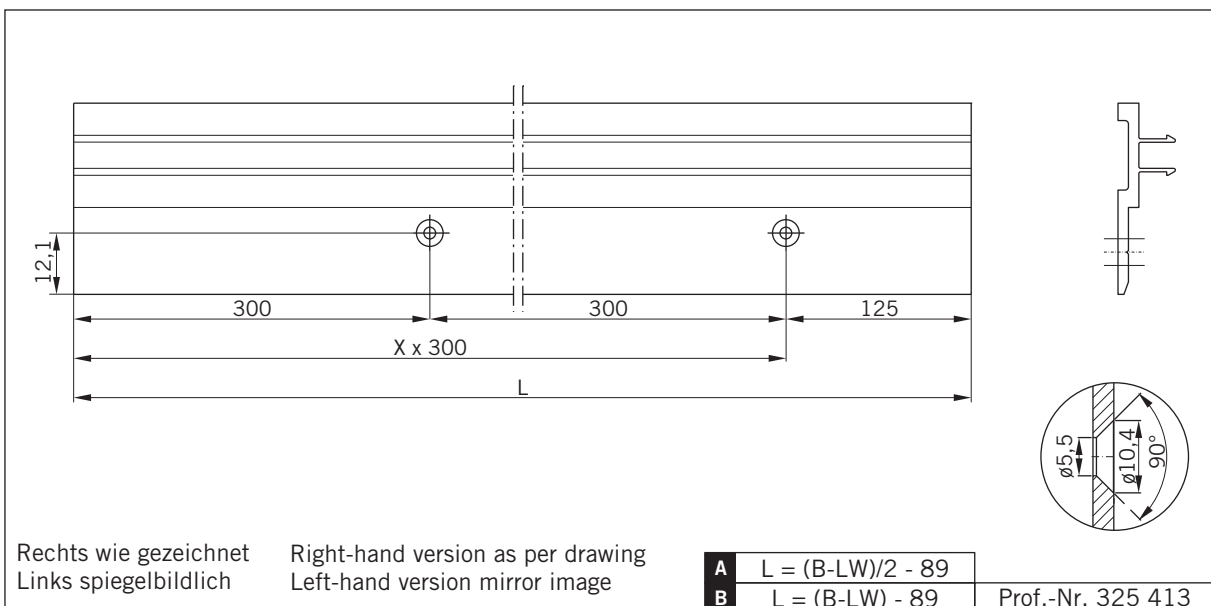
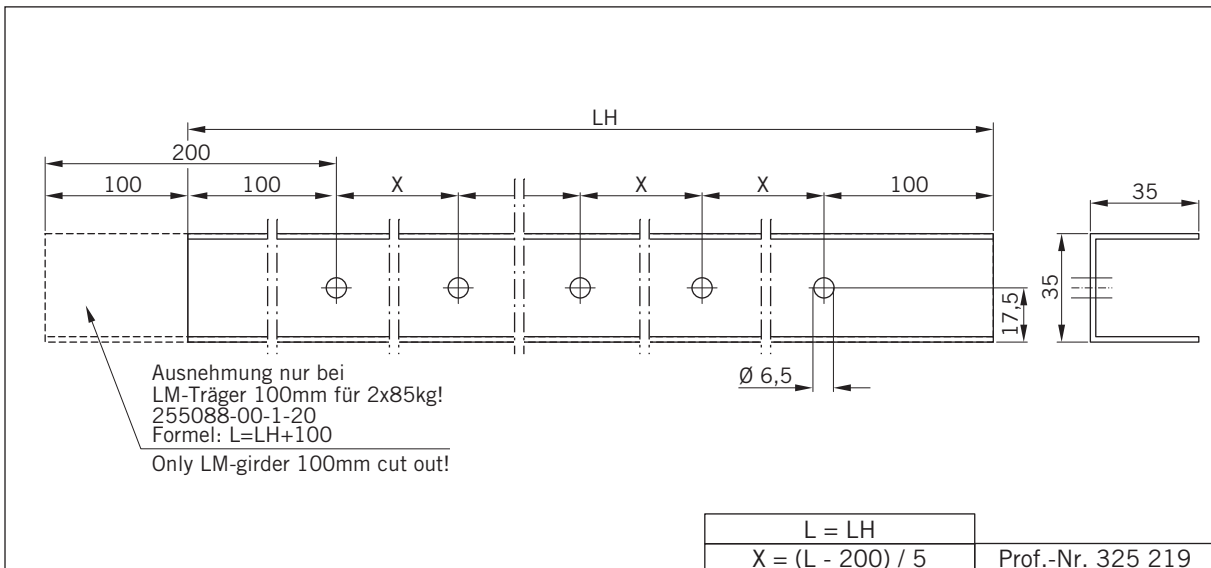
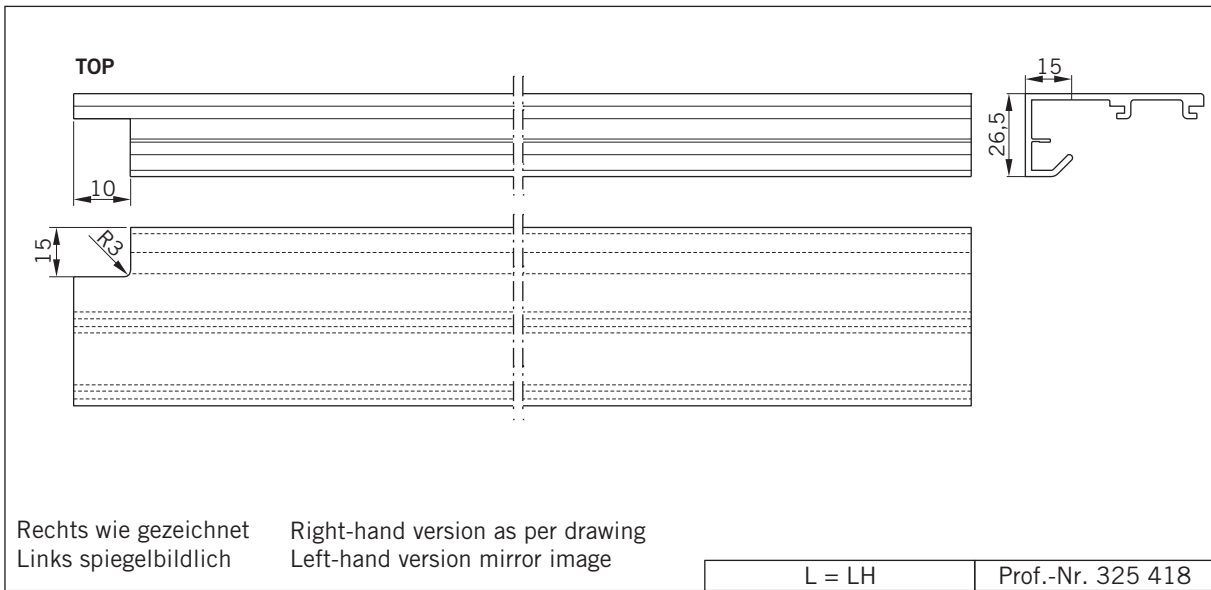



WN 069437 45632
16 02/09

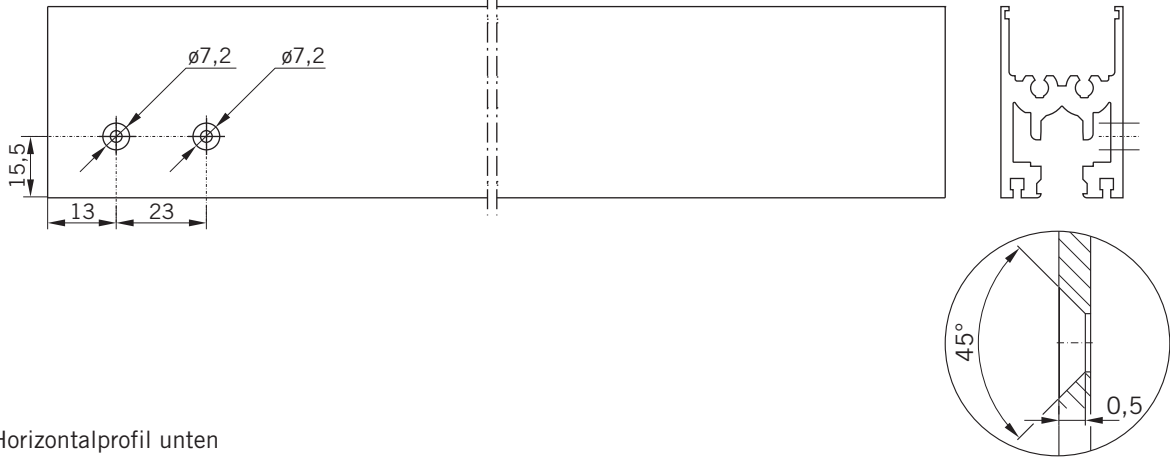

Horizontalprofil unten

Rechts wie gezeichnet
Links spiegelbildlich

Right-hand version as per drawing
Left-hand version mirror image

A	$L = (B-LW)/2 - 89$
B	$L = (B-LW) - 89$

Prof.-Nr. 325 408

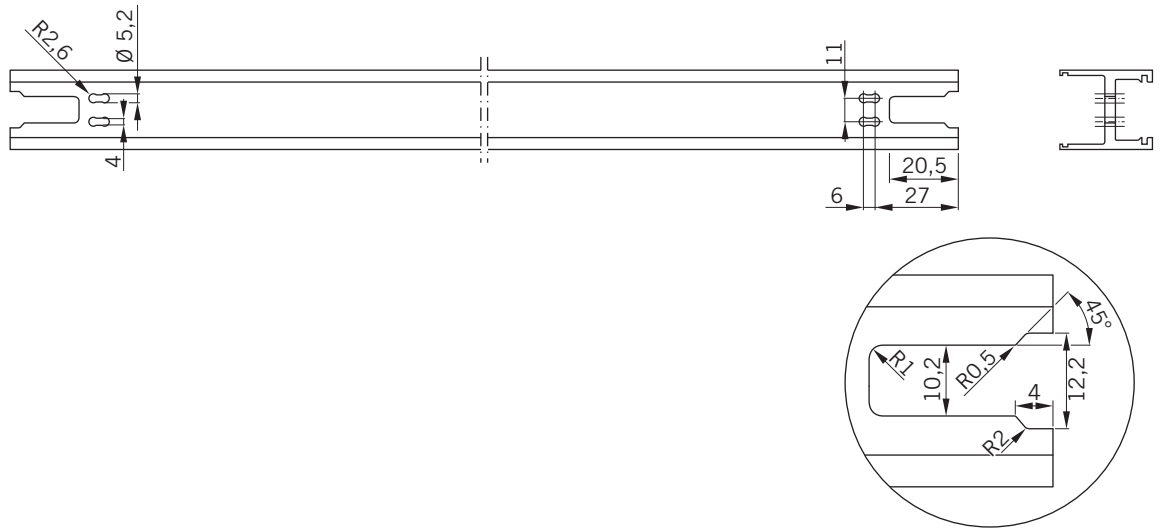

L = LH

Prof.-Nr.: 325 409



WN 069437 45632
17 02/09

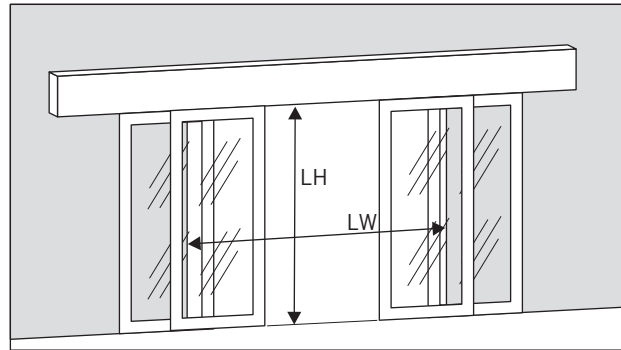

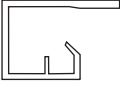
Profil/Zubehör Profils/accessories	Artikelnummer Article-number	Bezeichnung Name	Zuschnittsformel Cutting Formula	St. pc.
	325 420-XX-1-20 01 - 5100mm roh / mill finish 02 - 5100mm E6 / CO	Gegendichtungsprofil Interlock profile	L = LH	2
	004400310	Bodenführungsset Floor guide U-shape		2

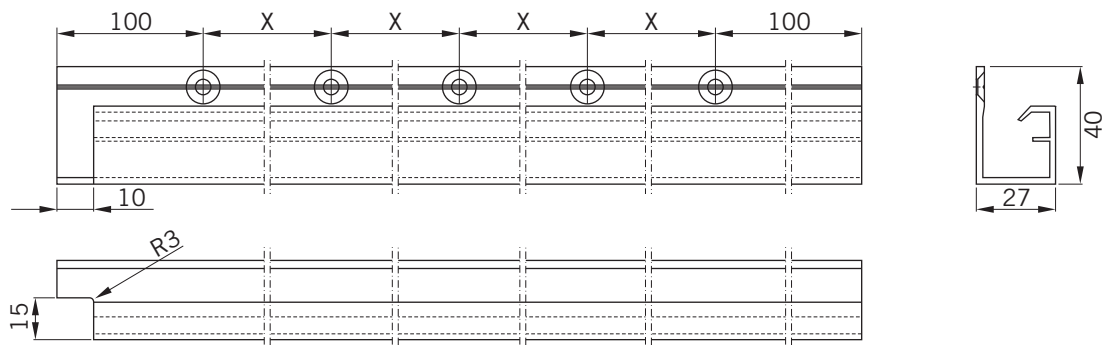
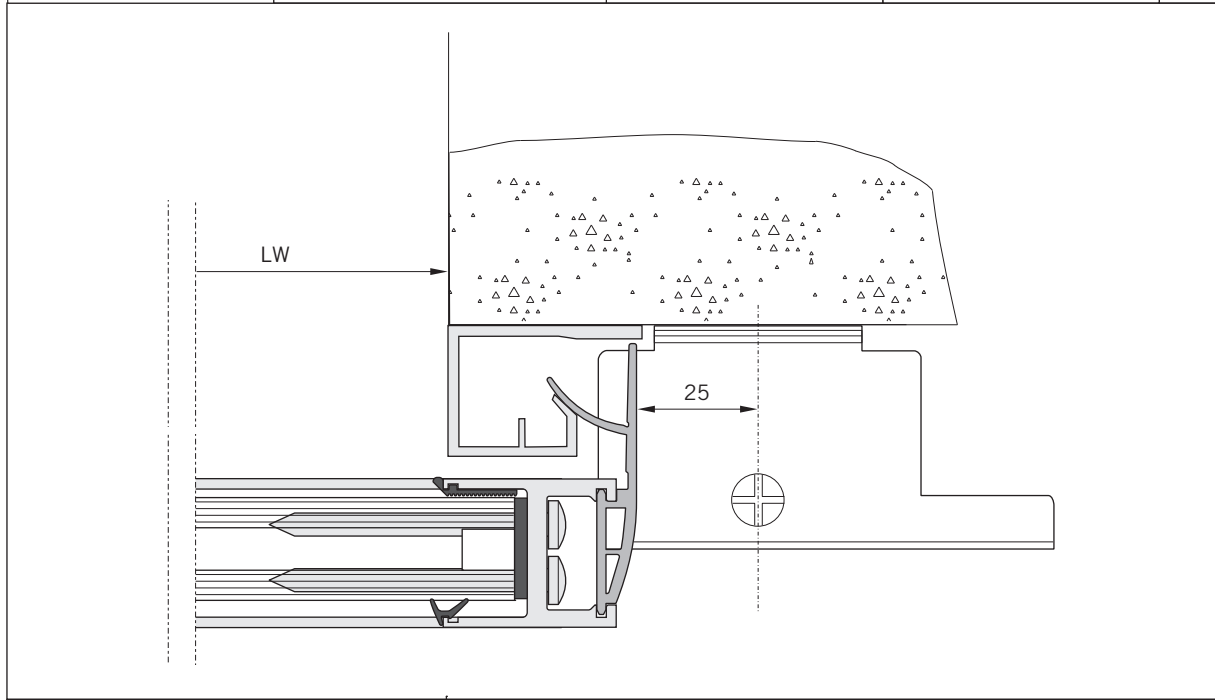

Rechts wie gezeichnet Right-hand version as per drawing
Links spiegelbildlich Left-hand version mirror image



L = LH

Prof.-Nr. 325 420

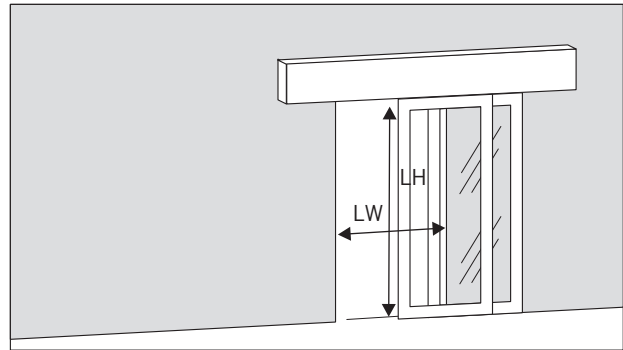

WN 059437 45532
18 02/09



Profil/Zubehör Profils/accessories	Artikelnummer Article-number	Bezeichnung Name	Zuschnittsformel Cutting Formula	St. pc.
	325 423-XX-1-20 01 - 5100mm roh / mill finsh 02 - 5100mm E6 / CO	Seitenanschlagwinkel side connection bracket	L = LH	1
	325 426-XX-1-20 01 - 5100mm roh / mill finsh 02 - 5100mm E6 / CO	Wandanschlagprofil wall connection profile	L = LH	1
 PVC schwarz	325 412-XX-1-20 01 - 2500mm 02 - 3200mm	Mitteldichtung central seal	L = LH	1
	4400310	Bodenführungsset Floor guide U-shape		1

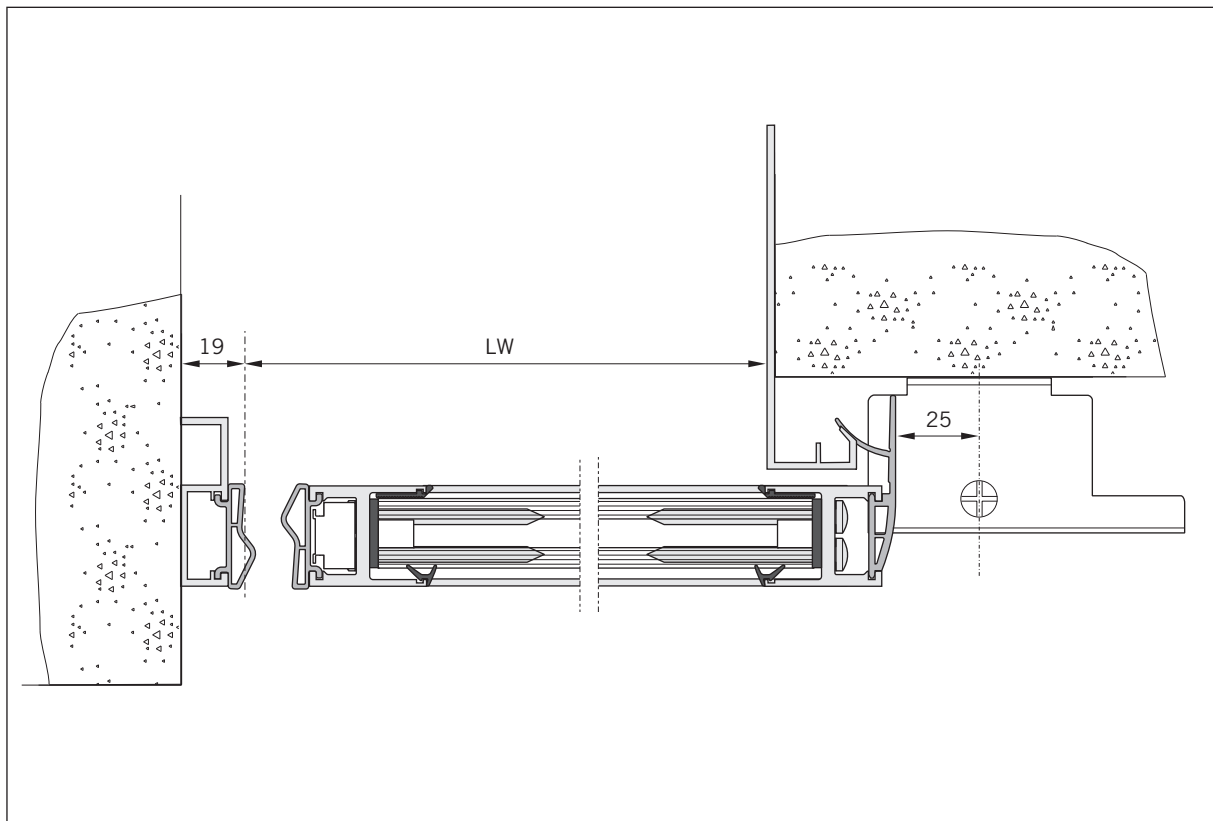



WN 059437 45532
19 02/09

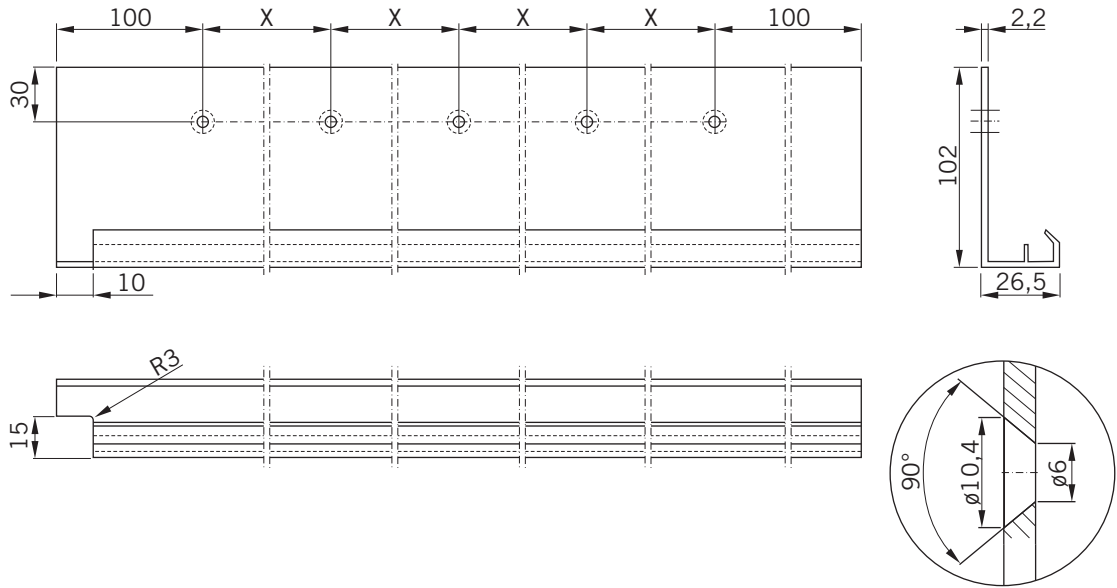

Rechts wie gezeichnet Right-hand version as per drawing
Links spiegelbildlich Left-hand version mirror image

L = LH

Prof.-Nr. 325 423

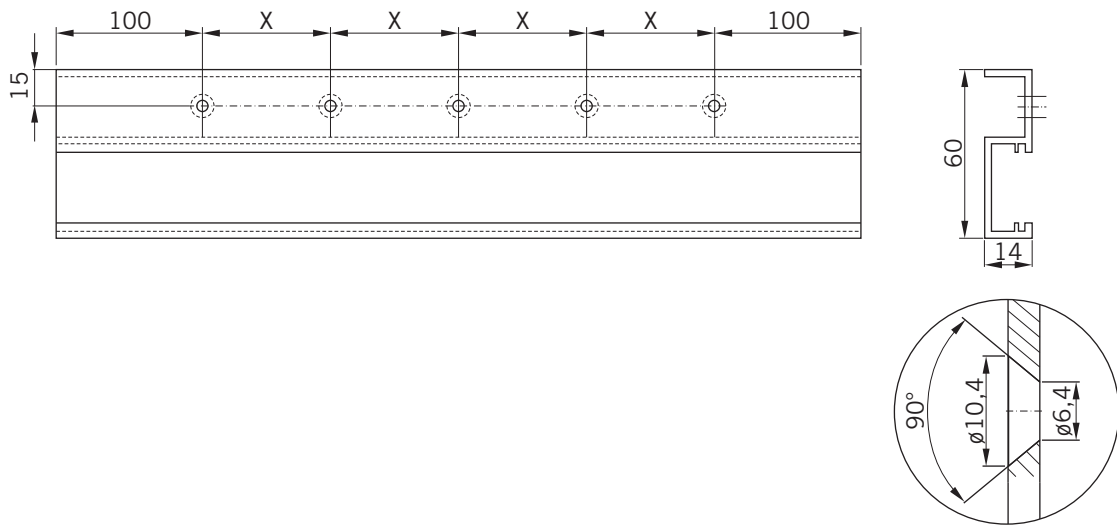

Rechts wie gezeichnet Right-hand version as per drawing
Links spiegelbildlich Left-hand version mirror image

L = LH

Prof.-Nr. 325 426



WN 069437 45532
20 02/09

Profile/Zubehör Profils/accessories	Artikelnummer Article-number	Bezeichnung Name	Kämpferhöhe Operator height	Zuschnittsformel Cutting Formula	Var. 01 / 1-teilig / 1 part only Var. 02 / 2-teilig / divided 2 parts Var. 03 / 3-teilig / divided 3 parts / Mitte / centre Var. 04 / 3-teilig / divided 3 parts / Außen / external				
		B = LE - 10							
	Zeichnungsnr. 257 025-01-1-40 Materialnr. 502091	Deckenabschluß U-Profil top closure U-profile		L = B + 10	1	1	1	1	
	325 408-XX-1-20 01 - 6250mm roh / mill finish 02 - 6250mm E6 / CO 06 - 4250mm roh / mill finish 07 - 4250mm E6 / CO	Horizontalprofil horizontal section	Var.01	L = B - 100	2				
			Var.02	$L = \frac{(B-30)}{2} - 70$	4				
			Var.03	L = LW		2			
			Var.04	$L = \frac{(B-LW)}{2} - 120$					4
	325 409-XX-1-20 01 - 5100mm roh / mill finish 02 - 5100mm E6 / CO	Vertikalprofil vertical section	100	L = H - (LH+120)	2	4	2	4	
			150	L = H - (LH+170)					
	325 219-XX-1-20 01 - 5100mm roh / mill finish 02 - 5100mm E6 / CO	Seitenabschluß U-Profil side closure U-profile	100	L = H - (LH+120)	2	2	2	2	
			150	L = H - (LH+170)	2	2	2	2	
 für Glasscheibe 8mm for glass pane 8mm	325 410-02-1-20	Verglasungsgummi- 8mm rubber seal		GB GH	2	4	2	4	
 für Glasscheibe 22mm for glass pane 22mm	325 424-01-1-20	Gummidichtung rubber seal		GB GH	2	4	2	4	
 für Glasscheibe 8+22mm for glass pane 8+22mm	325 137-02-1-20	Gummidichtung rubber seal		GB GH	2	4	2	4	

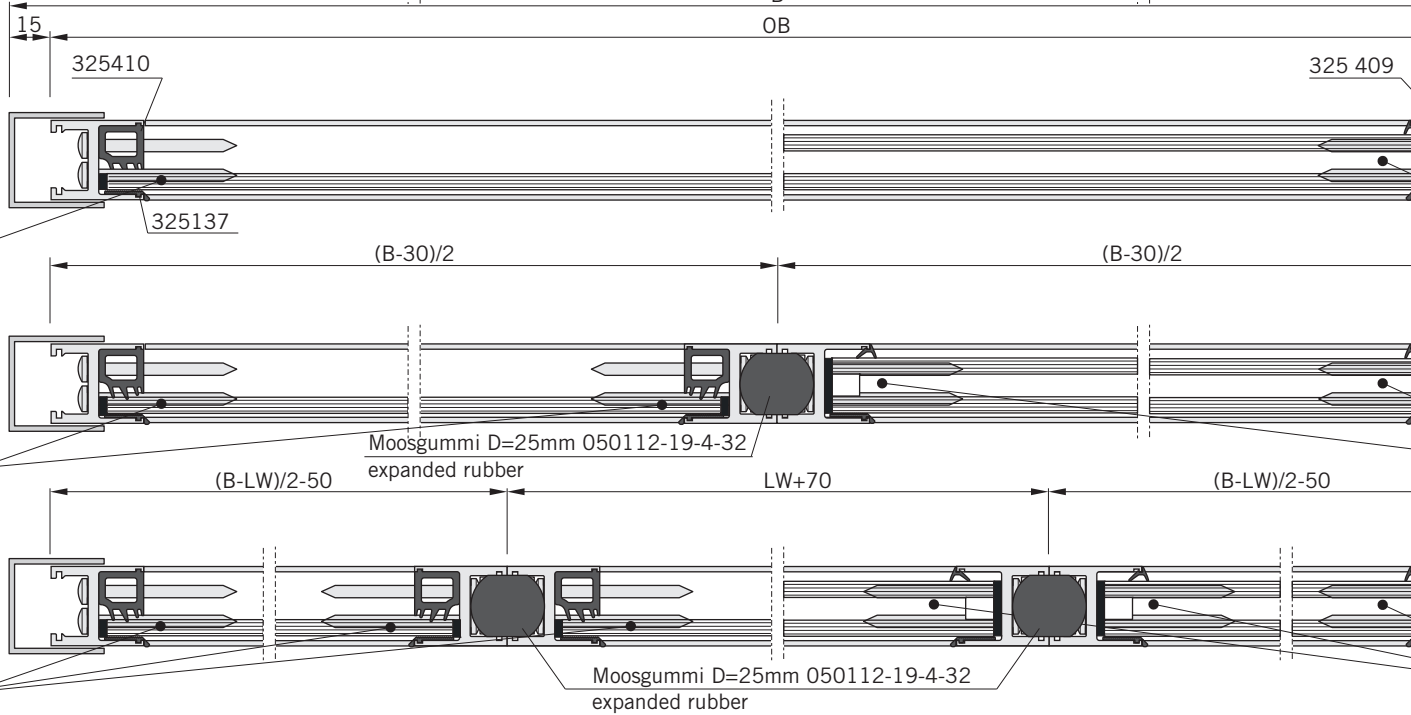
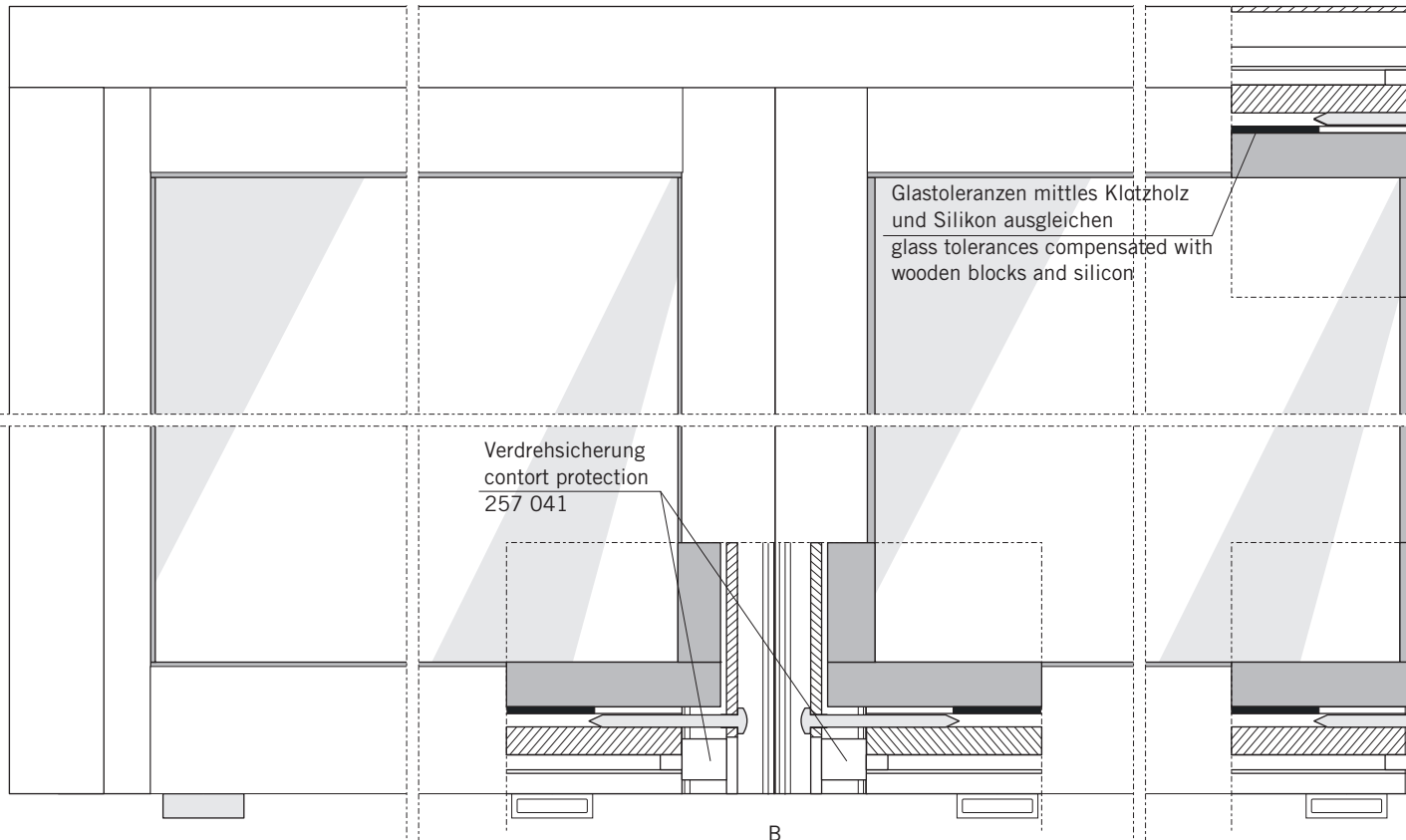



WN 069437 45532
23 02/09

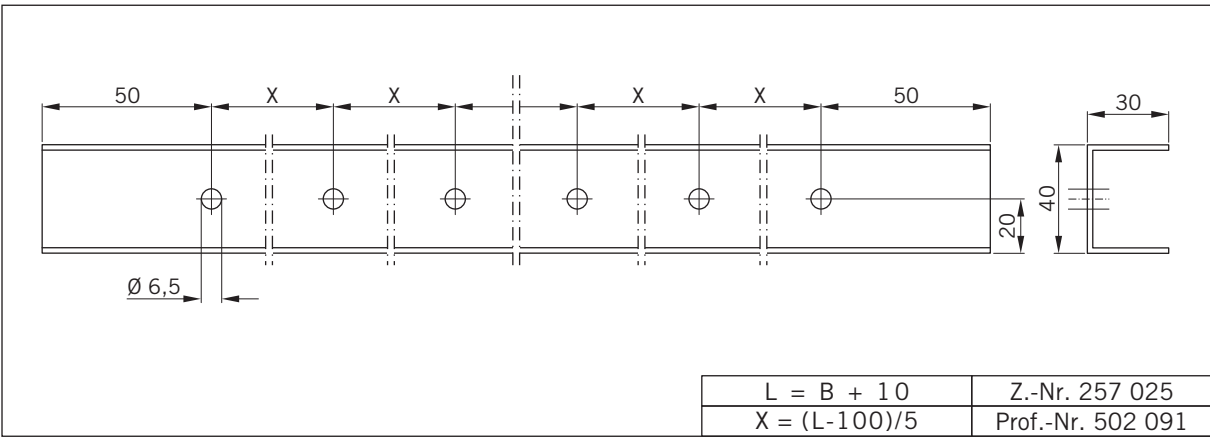
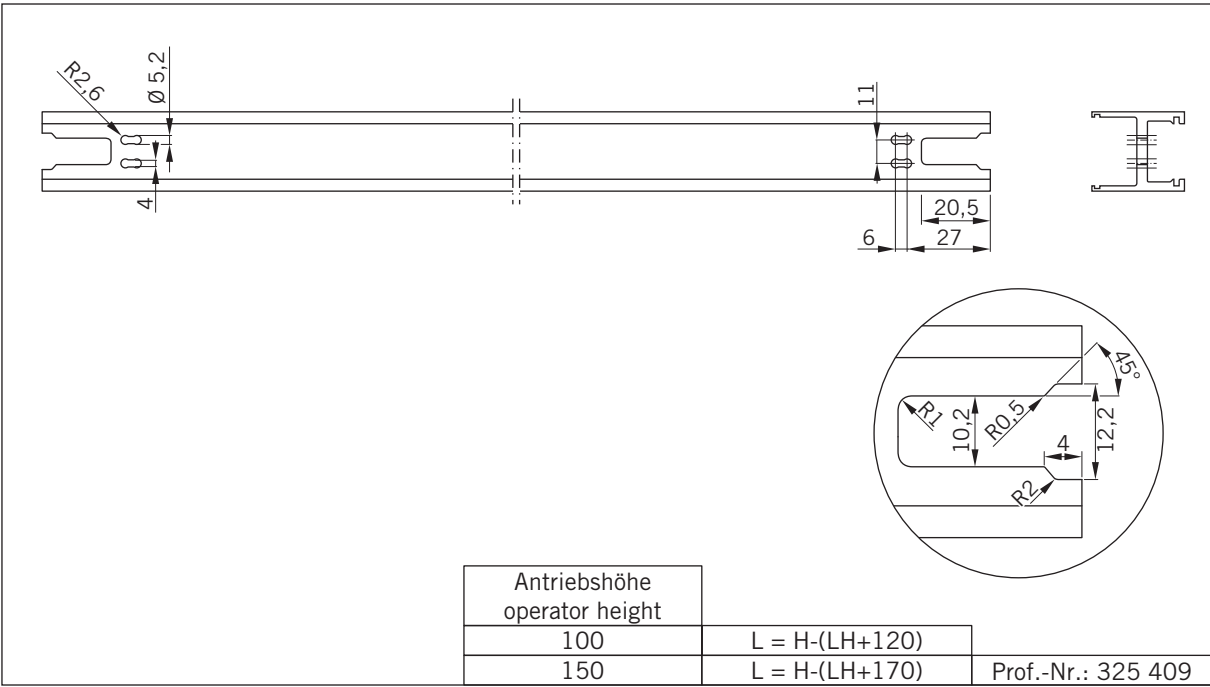

DORMA

TST-FLEX ES 200
Oberflurschiebetür
Floor-mounted door



WN 059437 45532
02/09