

# Door Manual

## All Glass Door with **DORMA Panic Handle DG1000-D Series**

### **DOOR FABRICATION (Panic Handle Installation) - Page 2**

Parts List, Tools and Supplies required  
Handle Removal from Packaging  
Installation of Handle to Door  
Actuator Post Alignment and Nylon Bushing Selection

### **DOOR INSTALLATION - Page 9**

#### **DOOR STOP WITH MANUAL STRIKE**

Header Preparation for Adjustable Door Stop with Manual Strike  
Installation of Panic Strike and Panic Handle Adjustment  
Bolt Adjustment for Proper Engaging With the Strike

#### **OPTIONAL - DOOR STOP WITH ELECTRIC STRIKE - Page 15**

*(E) Header Preparation for Adjustable Door Stop with Electric Strike*  
*(E) Installation and Adjustment of Door Stop – Strike*

### **HANDLE CARE AND MAINTENANCE - Page 16**

Care and Cleaning  
Stainless Steel Mirror Polished and Satin (Brushed) Finish  
Brass/Bronze Mirror Polish and Satin Finish  
Oil Rubbed Bronze  
Routine Maintenance  
Repair and Replacement (Replacing Cylinder)  
Repair and Replacement (Internal Components)

#### **IMPORTANT: PLEASE READ BEFORE INSTALLING THE HANDLE**

The following instructions will reduce your chances of experiencing problems during installation, and ensure smooth, trouble-free operation of the handle.

# DOOR FABRICATION (Panic Handle Installation)

## Introduction

Congratulations on your selection of the DORMA Panic Handle DG1000. The DORMA system is designed to allow maximum view and a contemporary look to your all glass doors. The DORMA system is UL listed and includes a "Dogging" feature which allows the owner to defeat the locking action during business hours.

By following the instructions in this manual, we believe you will experience a trouble free installation of the system.

Should you have any question about this system or any other DORMA products, please contact us at (800) 523-8483 or visit our website at [www.dorma-usa.com](http://www.dorma-usa.com).

## Parts List

Parts you will be handling during the Handle Removal from the packaging and during the Handle Installation to the door:

- ✓ Flat Head Socket Screw,
- ✓ Actuator Post with cylinder operating pin and handle return pin with spring,
- ✓ Nylon Bushing for Triple Holes,
- ✓ Cylinder Housing or Retainer Plate when no Cylinder is used,
- ✓ Adapter Block with installation screw,
- ✓ Threaded Pin,
- ✓ Exterior Handle Retainer with rubber bushing,
- ✓ Cap and Rubber Bushing,

## Tools and Supplies needed:

- 1set - DORMA supplied hex wrenches
- 1set - DORMA supplied Nylon Bushings (see Nylon Bushing Selection)
- 1 ea - 10" Non-Marring Channel Lock Pliers (optional)
- 1 ea - DORMA Spanner Wrench (MPHSW)
- 1 ea - DORMA supplied Thread Locker
- 1 ea - Rubber strip, i.e. 1/8" thick rubber setting block

## Removal from Packaging

Handle comes mounted on the Mounting Board inside the wooden crate. To remove the handle from the board, please follow steps 1 through 3 below. →

1. To remove Actuator Post: Unscrew flat head socket screw with hex wrench, being careful that the keyed actuator device does not fall from the backside of the plywood mounting board. Now lift the handle away from plywood to gain access to the actuator post and tilt the actuator post toward the horizontal handle section, then remove. Be careful not to lose the cylinder-operating pin, handle return plunger and spring, or the triple hole bushing. ↓

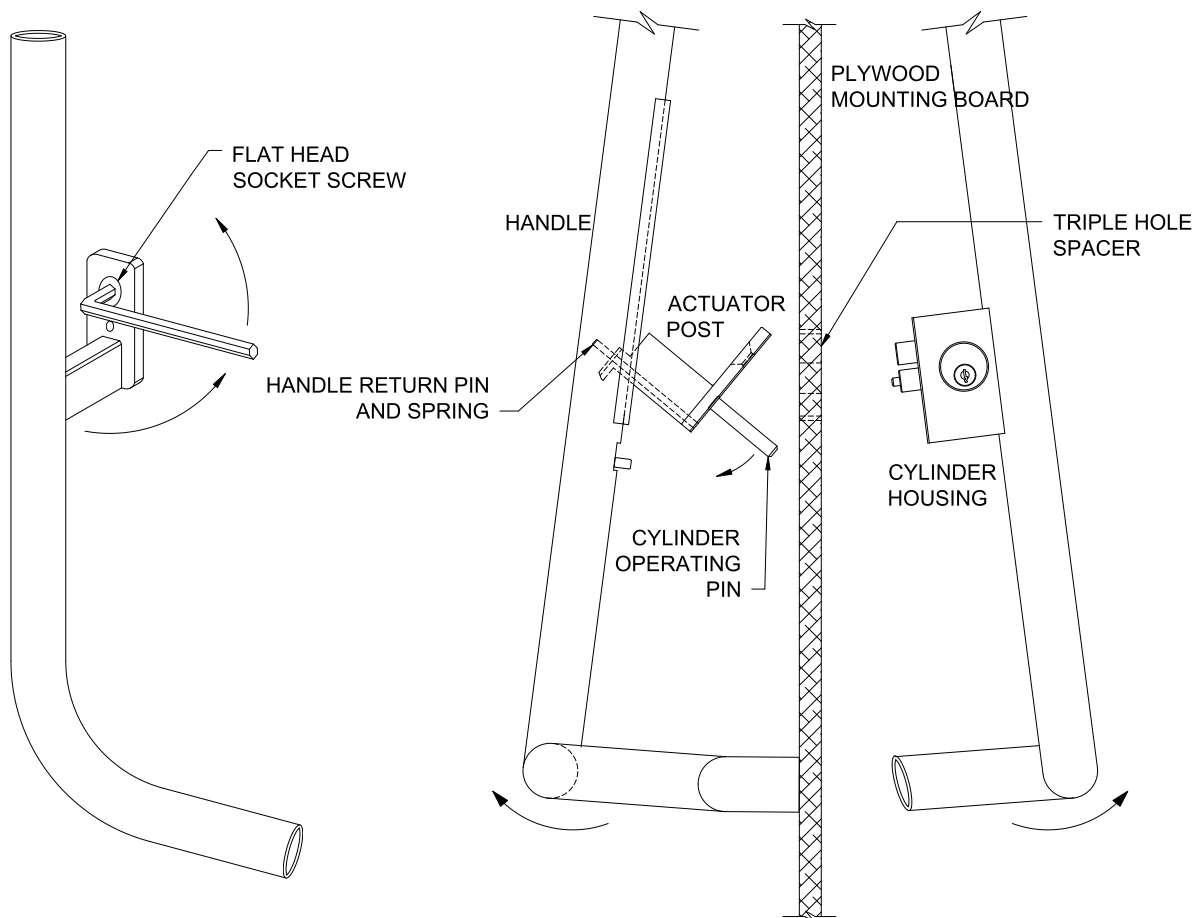
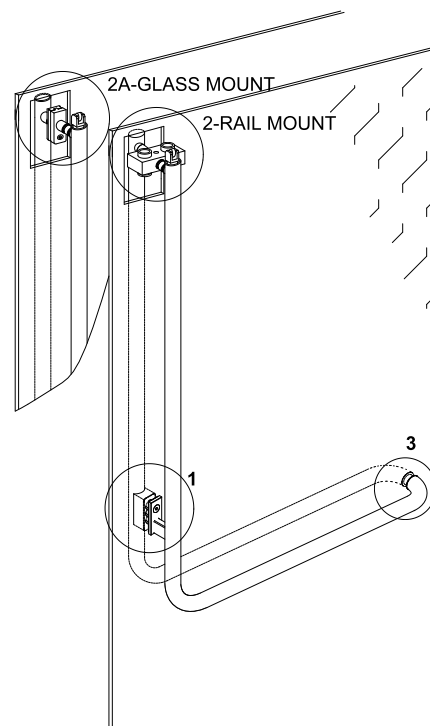

2. FOR RAIL MOUNT HANDLE. Rotate round connector pivot fitting counter clockwise and remove from Adapter Block. Note: Use pliers and rubber strip (to protect finish) for removal of round connector. Remove the Exterior Handle Screw to release the exterior handle from the adapter block.

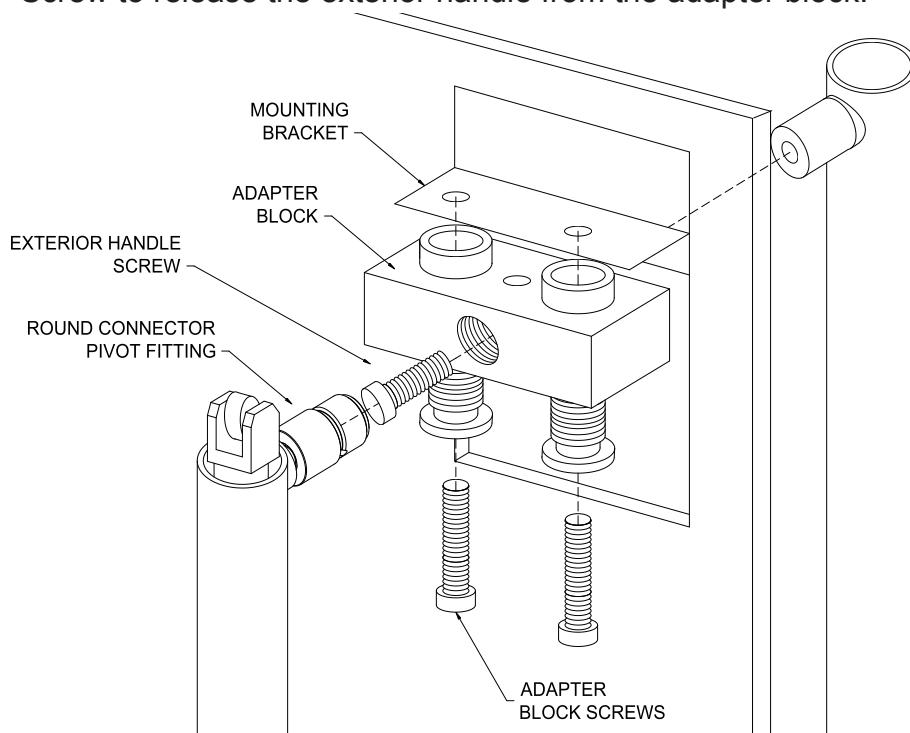

- 2.A. FOR GLASS MOUNT HANDLE. Remove Socket Head Cap Screw from Interior Pivot Bracket and Exterior Bracket. Be careful not to lose Gaskets located between Interior and Exterior Brackets

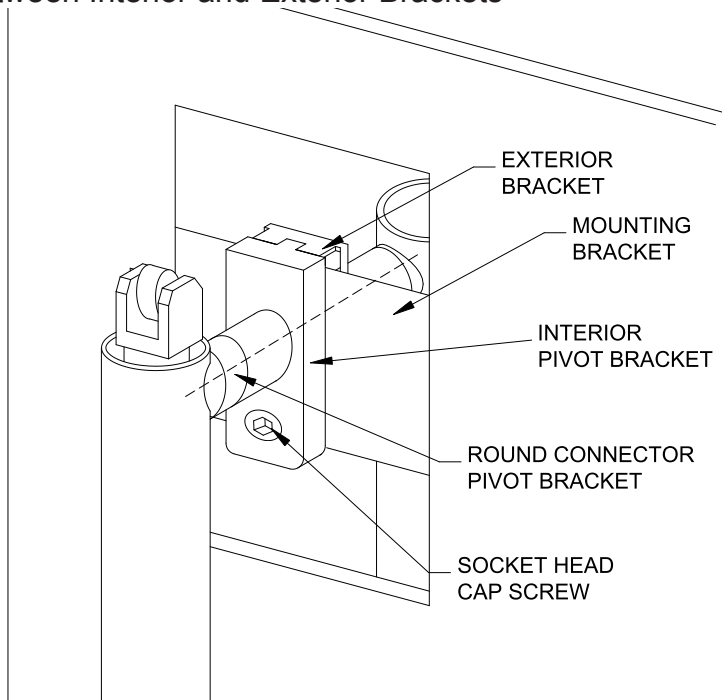

3. Remove threaded pin from the bottom of the horizontal handle and pull horizontal handle away from plywood. Use the **DORMA Spanner Wrench (part number MPHSWE)** to remove the exterior horizontal handle retainer and rubber bushing

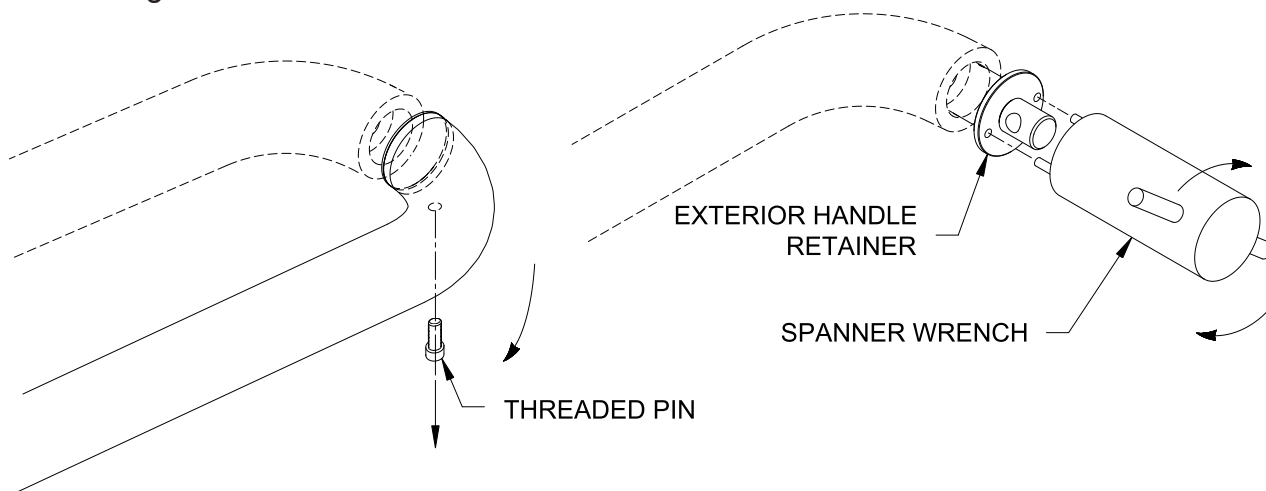

Apply **THREAD LOCKER** to all fasteners used to mount handle on doors.



## Installation of Handle to Door:

- Lay glass flat with the exterior side facing down on a pair of saw horses.
- Attach Door Rails (if applicable) positioning the mounting hole in the rail at the inside face/ strike edge of door. DORMA DRS Rail System Installation instructions attached.

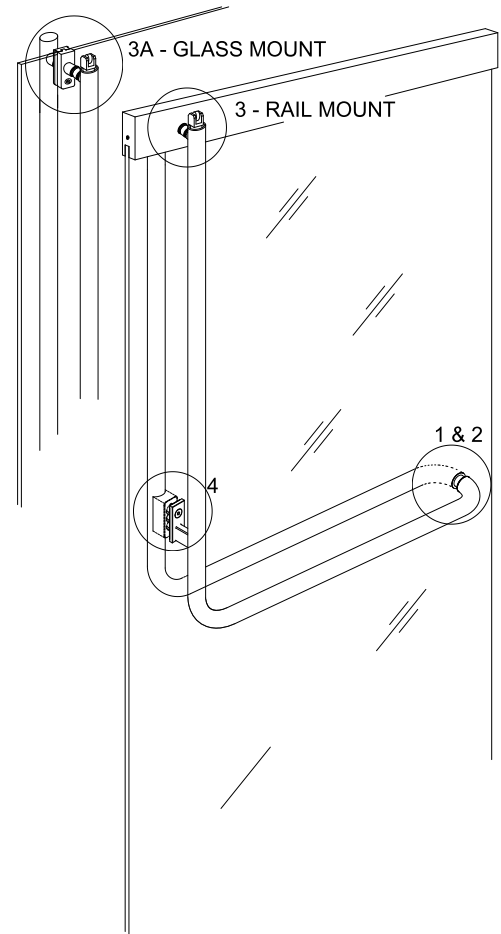

1. Push exterior horizontal handle retainer with rubber bushing through glass hole from interior side, into horizontal handle, and tighten with spanner wrench. ↓

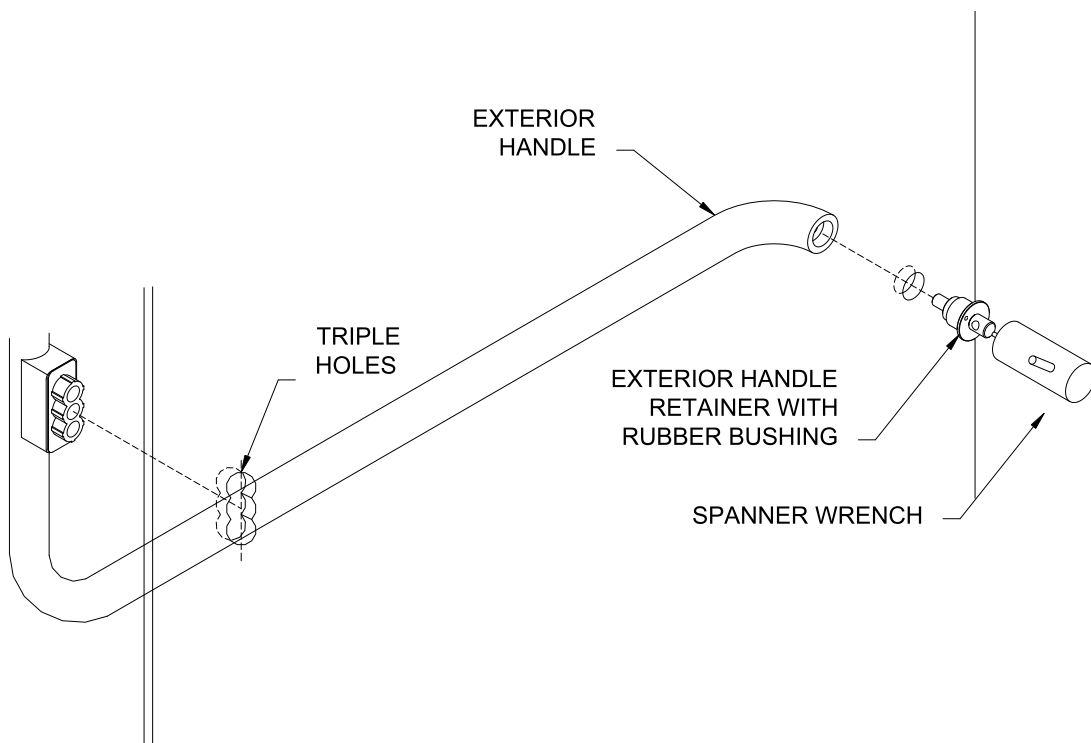

Apply **THREAD LOCKER** to all fasteners used to mount handle on doors.

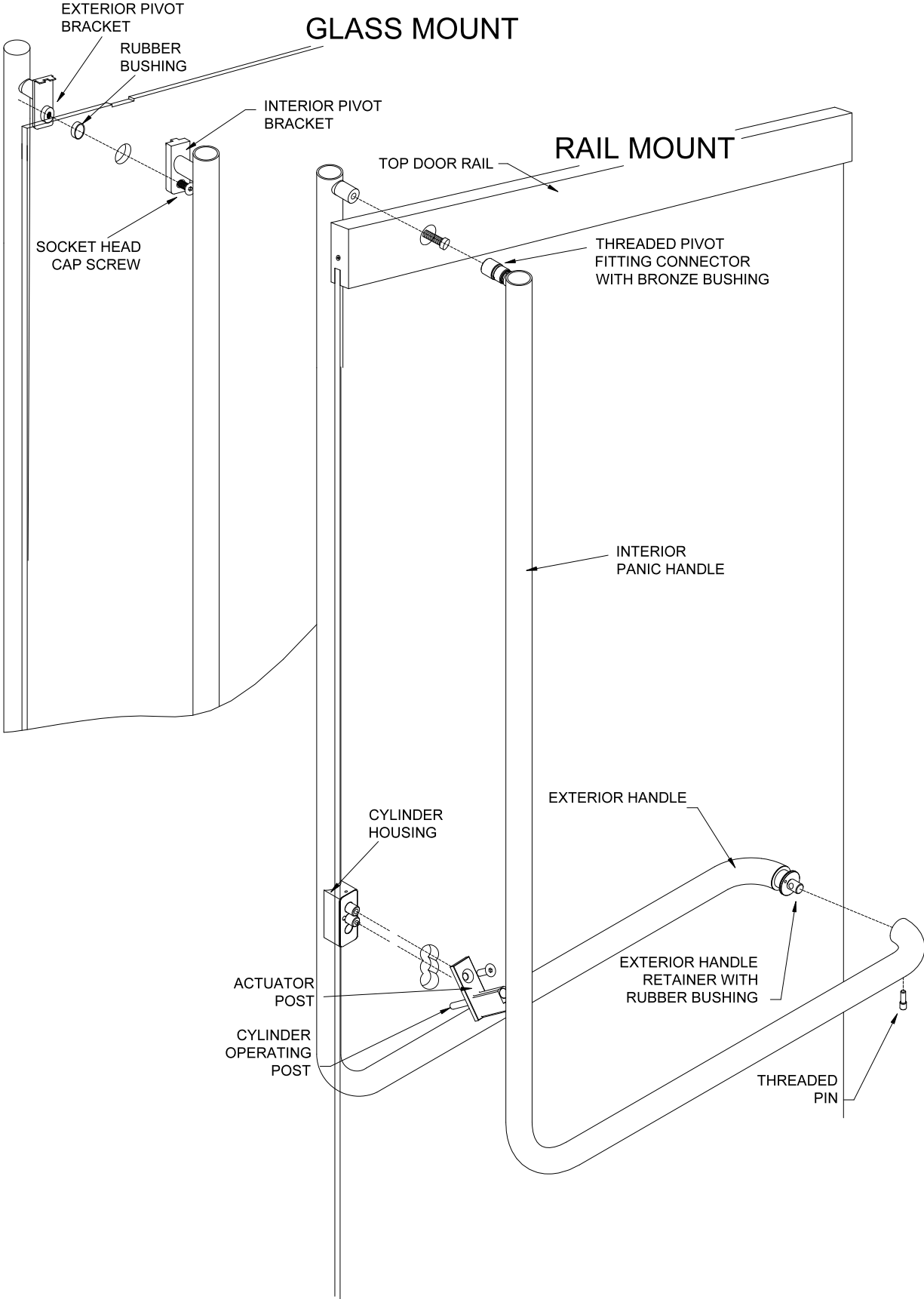

Apply **THREAD LOCKER** to all fasteners used to mount handle on doors.



2. Place interior panic handle over pivoting end of exterior horizontal handle retainer, first rotating the pivoting projection so that the cross hole is aligned to the hole in the horizontal bar. Insert threaded pin and tighten with hex wrench.
3. **RAIL MOUNT HANDLE.** Screw the top of the exterior handle through the rail and tighten the threaded pivot fitting connector to the adapter block. Adapter block is mounted inside the top rail with two bolts using predrilled holes. Position/height of this block is adjustable for best alignment with the "bracket connector" hole on the rail.

*If experiencing difficulties aligning top pivot bracket connector with the hole on the rail, please refer to the DORMA Door Rails installation instructions for possible adjustments of the top rail.*

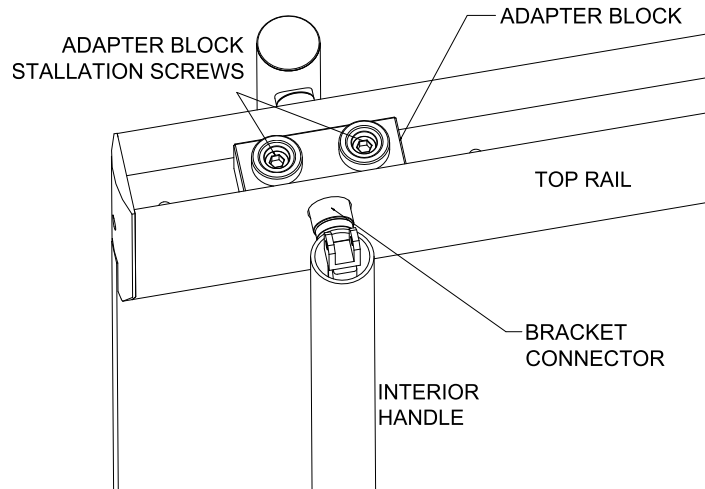

4.A. **GLASS MOUNT HANDLE.**

Insert rubber bushing into glass hole at top of glass door. Place exterior pivot bracket against exterior side into notched portion of glass. Align interior handle with exterior pivot bracket and tighten low head cap screw

4. Lift handle and insert actuator post containing cylinder operating pin, return spring and return plunger into handle. Place flat base of actuator post against glass over the triple hole nylon bushing. Screw actuator post to keyed actuator device.

- 
- **This completes the Panic Handle installation to the door. Please be careful not to lift the door with any portion of the Panic Handle.**
  - **When handling the Door assembly, it is recommended to use Roller-Blocks for supporting the corner of the door rail while rolling into the vertical position. This will prevent damage to the end cap.**



# DOOR INSTALLATION

## Introduction

Congratulations on your selection of the DORMA Panic Handle System. The DORMA system is designed to allow maximum view and a contemporary look to your all glass doors. The DORMA system is UL listed and includes a "Dogging" feature, which allows the owner to defeat the locking action during business hours.

By following the instructions in this manual, we believe you will experience a trouble free installation of the system.

Should you have any question about this system or any other DORMA products, please contact us at (800) 523-8483 or visit our website at [www.dorma-usa.com](http://www.dorma-usa.com).

## Parts List

Single or Double Adjustable Door Stops with required installation screws.  
Keys, supplied with Panic Handle Door Installer Manual.

## Tools and Supplies needed:

- 1 ea - 1/8" hex Wrenches, supplied with Panic Handle
- 1 ea - 1/4" hex Wrenches, supplied with Door Stop
- 1 ea - Thread Locker, supplied with Door Stop

## Header Preparation for Single and Double Adjustable Door Stops with MANUAL STRIKE

Prepare Header with threaded holes sized and located as illustrated  
**DOUBLE DOOR**

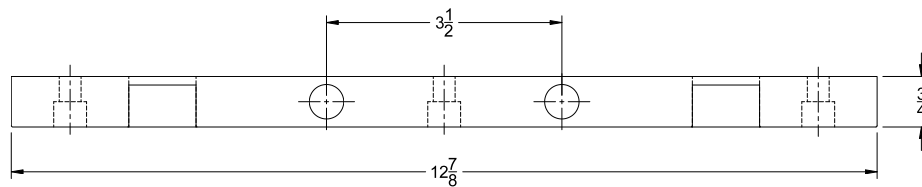
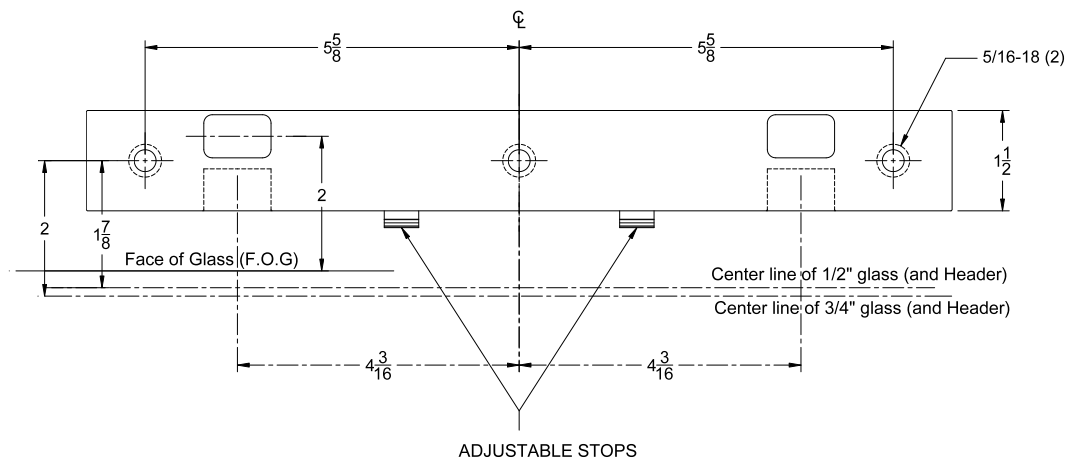

## SINGLE DOOR

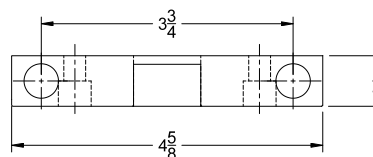
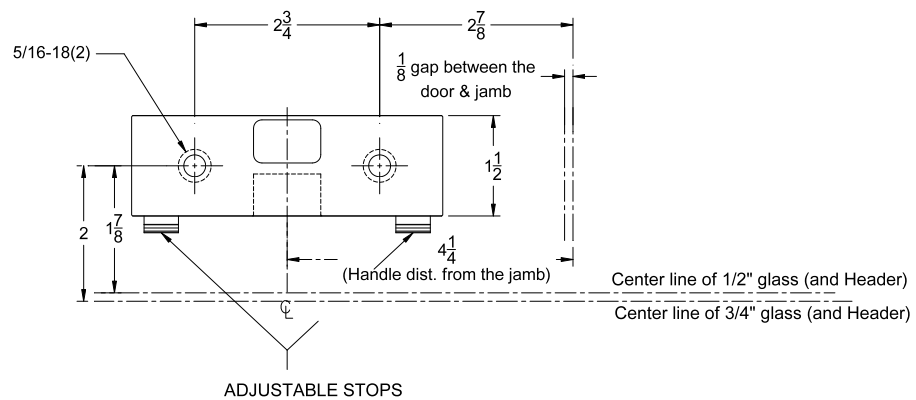

## Installation and Adjustment of Door Stop/ Strike Door Stop with MANUAL STRIKE

### INSTALLATION

Install strike in header using provided socket head cap screws. Apply thread locker to bolt threads prior to tightening with hex wrench.

After door installation, when the door closes and comes to rest on the rubber stop pad(s) the retractable bolt should automatically move upward engaging the strike as illustrated. Distance from the Face of the Glass (F.O.G) to the center of the handle should be 2".

If retractable bolt is not engaging with the strike, door stops should be moved in, or if retractable bolt is lose inside the strike (doors are rattling), stops should be moved out.

### ADJUSTMENT

To adjust the stop, remove the rubber end piece which uncovers a socket for a 1/4" hex wrench, insert wrench and rotate in or out as needed. One full turn is equal to approximately 1/16" of adjustment.

## DOOR STOP / STRIKE APPLICATIONS

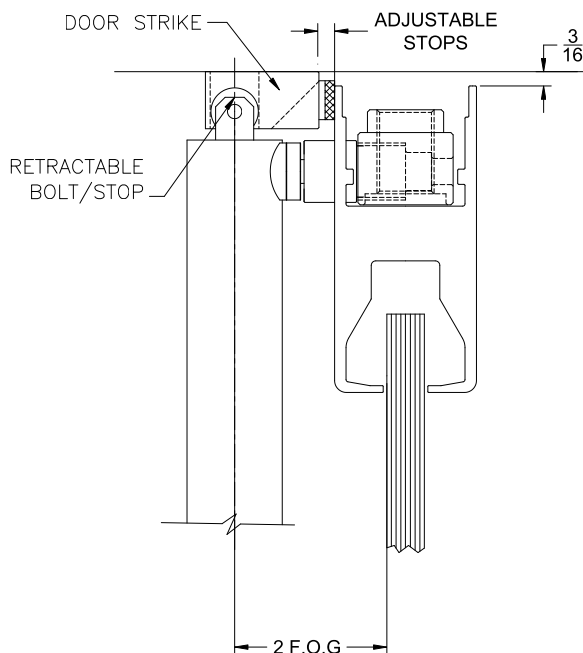

DOOR RAIL MOUNTING

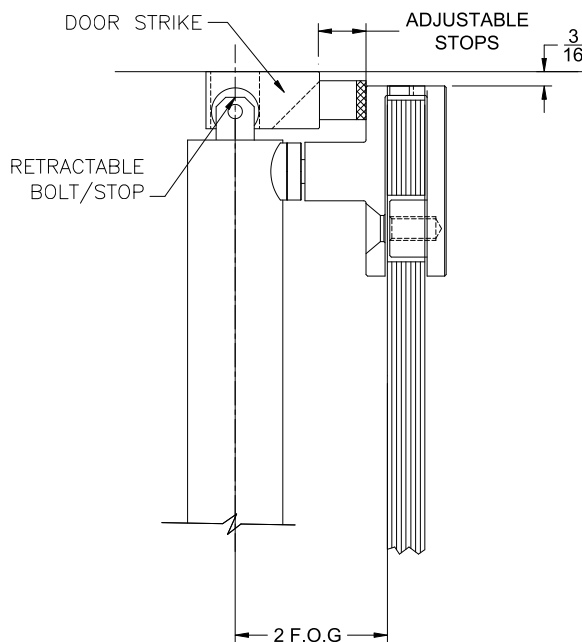

DIRECT TO GLASS MOUNTING

## Bolt Adjustment for Proper Engaging With the Strike

1. The retractable bolt can be adjusted up and down. The centerline of the roller at the top of the retractable bolt should penetrate the strike for a minimum 1/8". The maximum upward adjust is 3/4" measured from the top of the handle tubing to the top of the bolt that retains the roller.
2. To make this adjustment, with an hex wrench, remove the flat head screw at the top of Panic Handle. DO NOT Remove the Slotted Head Screw.
3. Rotate the bolt in either direction full 360° turn to obtain desired height adjustment.
4. Rotate bolt to align interior threaded hole with countersunk hole in tubing.
5. Replace flat head screw.

FAILURE TO REPLACE THIS SCREW WILL ALLOW RETRACTABLE BOLT TO RANDOMLY ROTATE CAUSING THE BOLT TO IMPROPERLY ENGAGE THE STRIKE.

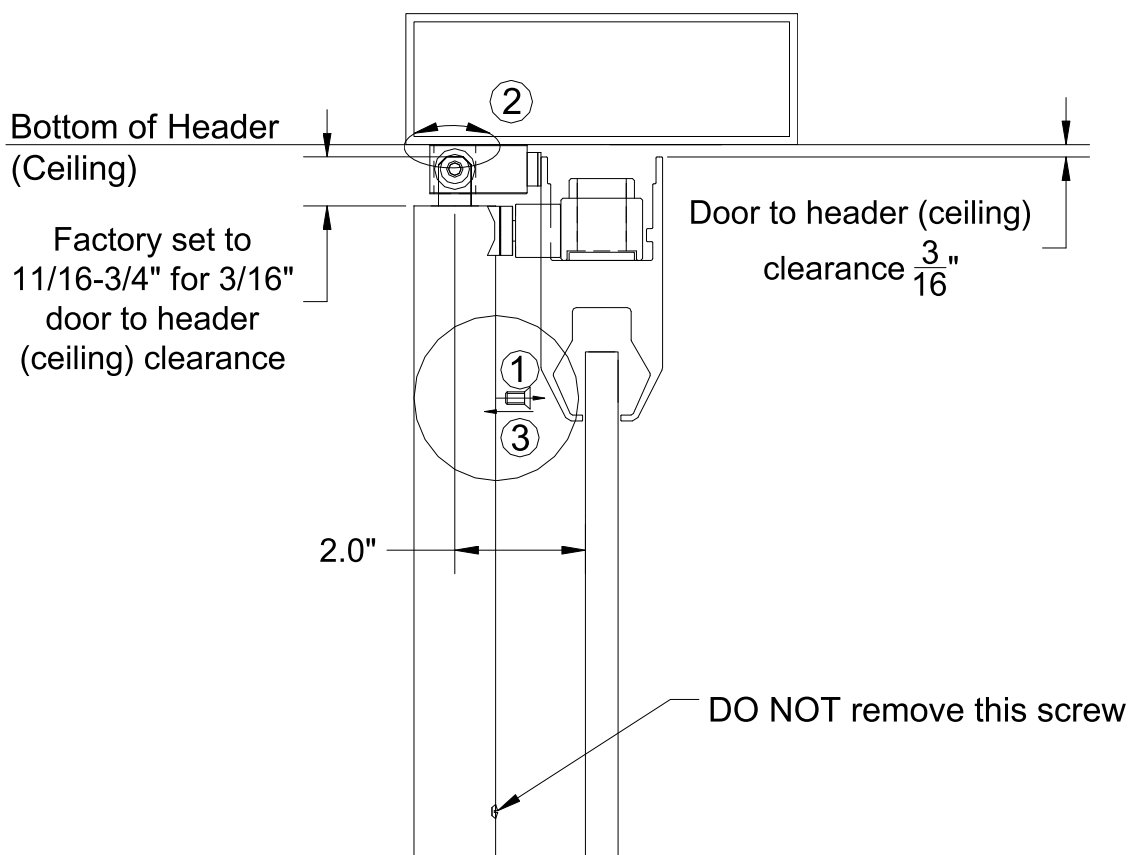

## OPTIONAL

### (E) Header Preparation for Adjustable Door Stops with **ELECTRIC STRIKE**

Your Electric Stop / Strike comes with header preparation template.  
Prepare Header with threaded holes sized and located as illustrated

#### DOUBLE DOOR

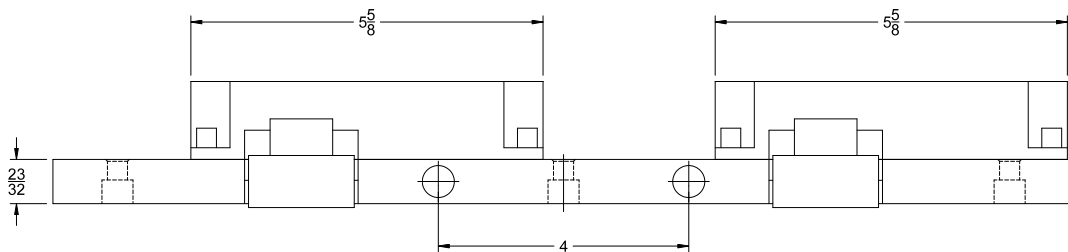
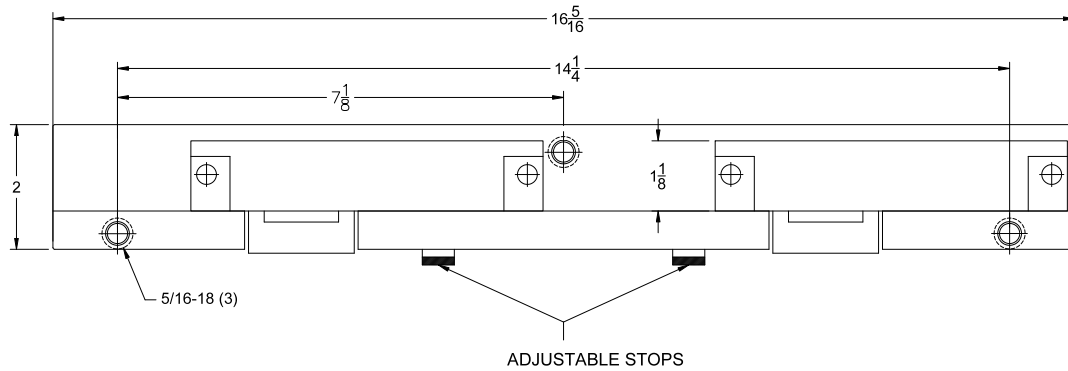

#### SINGLE DOOR

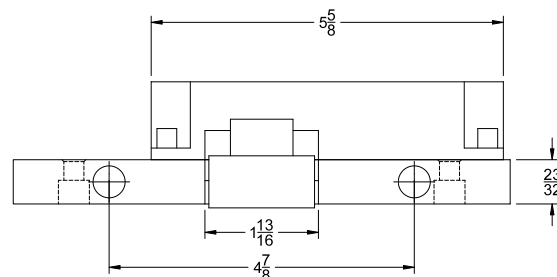
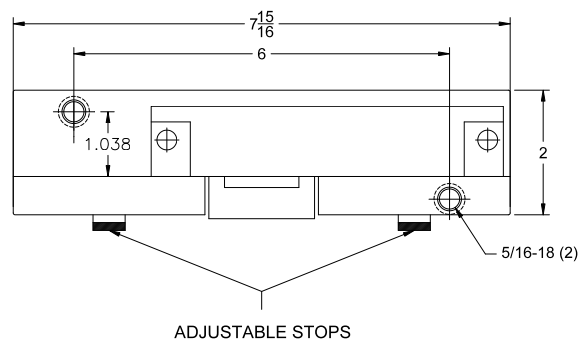

## (E) Installation and Adjustment of Door Stop - Strike. Door Stop with ELECTRIC STRIKE

### INSTALLATION

Remove Cover Retaining Screw and Door Stop Cover.

Install Door Stop - Strike in header using provided socket head cap screws (Door Stop Mounting Bolts show on the illustration). Apply thread locker to bolt threads prior to tightening with hex wrench. Replace Door Stop Cover and fasten with Cover Retaining Screw.

### INSTALLATION OF DOOR STOP WITH ELECTRIC STRIKE

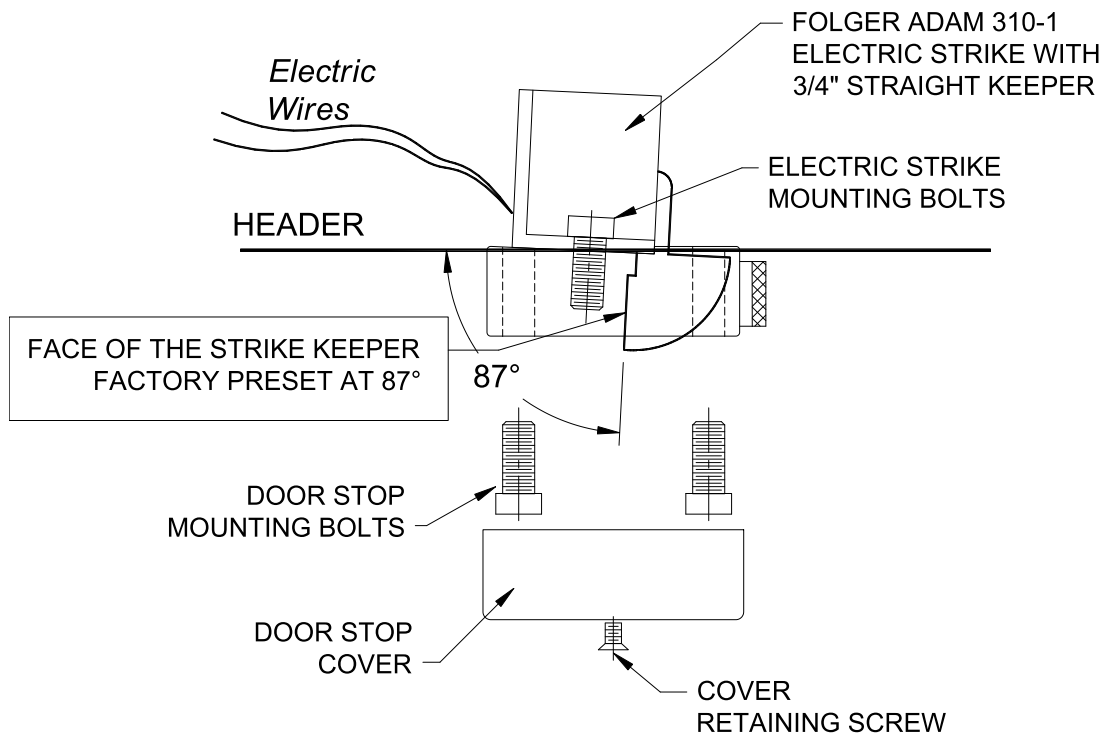

#### IMPORTANT NOTE FOR ELECTRIC STRIKE REPLACEMENT.

Face of the Strike Keeper MUST be set at 87 deg. as illustrated.

To replace Electric Strike:

- Turn off power to electric strike.
- Remove Cover Retaining Screw and Door Stop Cover.
- Remove Door Stop Mounting Bolts and gently lower Door Stop-Latch Keeper.

#### **DISCONNECT ELECTRICAL WIRING**

- Remove Electric Strike Mounting Bolts and install New Electric Strike.
- Reconnect wires to new Electric Strike using appropriate wire connectors.
- Apply Threadlocker and tighten Electric Strike Mounting Bolts
- Mount Door Stop / Latch Keeper in header, and Replace Door Stop Cover.
- Turn on power to Electric Strike.
- Verify that the strike operates properly.

## Adjustment of Door Stop - Strike

After door installation, when the door closes and comes to rest on the rubber stop pad(s) the retractable bolt should automatically move upward engaging the strike as illustrated. Distance from the Face of the Glass (F.O.G) to the center of the handle should be 2".

If retractable bolt is not engaging with the strike, door stops should be moved in, or if retractable bolt is loose inside the strike (doors are rattling), stops should be moved out.

### ADJUSTMENT

To adjust the stop, remove the rubber end piece which uncovers a socket for a 1/4" hex wrench, insert wrench and rotate in or out as needed. One full turn is equal to approximately 1/16" of adjustment.

## DOOR STOP / EL. STRIKE APPLICATIONS

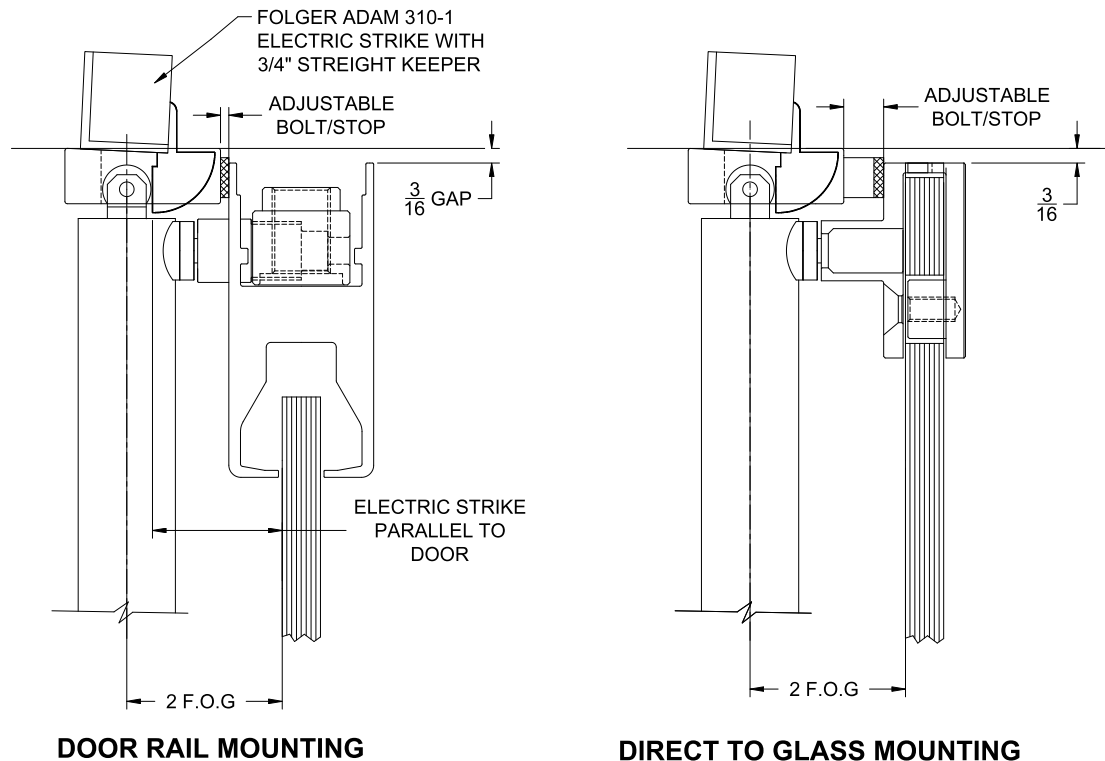

This completes the door installation.

## HANDLE CARE AND MAINTENANCE

### Introduction

Congratulations on your selection of the DORMA Panic Handle System. The DORMA system is designed to allow maximum view and a contemporary look to your all glass doors. The DORMA system is UL listed and includes a "Dogging" feature, which allows the owner to defeat the locking action during business hours.

By following the instructions in this manual, we believe you will experience trouble free operation over the life of the system.

Should you have any question about this system or any other DORMA products, please contact us at (800) 523-8483 or visit our website at [www.dorma-usa.com](http://www.dorma-usa.com).

### Care and Cleaning

#### Stainless Steel

Mirror and Satin polished Stainless Steel are one of the most durable and easiest finishes to maintain.

#### **Mirror Polished Stainless Steel:**

Mirror polished stainless steel finishes should be cleaned with a foam spray cleaner.

**Do not** use circular motions when polishing.



### **Satin Polished Stainless Steel (Brushed):**

Satin polished stainless steel finishes should be cleaned like Mirror polished Stainless Steel, just **with** circular motions in the same direction as the grain texture.

For periodic maintenance, satin stainless steel can be rubbed with an abrasive pad.

[Scotch-Brite General Purpose Hand Pad 7447 by 3M](#), or

[Scotch-Brite Ultra Fine Hand Pad 7448 by 3M](#), or

[Scotch-Brite General Purpose Scrubbing Pad 9650 by 3M](#).

The finish should always be rubbed in the same direction as the grain texture.

### **BRASS / BRONZE**

Polished and Satin finish applied to brass or bronze must be routinely maintained to retain the desired appearance. The darkening or black spotting on the brass or bronze surface is simply oxidation taking place. If left untreated brass and bronze will eventually turn entirely, but unevenly, dark. This dark oxidized state is the natural color of all copper alloys.

Frequency of the treatment of brass and bronze finishes depends on use and abuse, location, weather conditions, or exposure to marine air.

DORMA does not recommend any protective coating over the brass or bronze finish. These coatings provide only temporarily reprieve from the eventual oxidation that will occur on any brass or bronze finish.

Lacquer finishes are susceptible to scratching and abrasion. Once the surface of the lacquer has been damaged, oxidation will take place. Oxidation of the brass or bronze will appear as black spots. Scratches in the lacquer coating cannot just be covered up or sprayed over. Repair requires the stripping of the lacquer from the entire part using solvents. Then the lacquer must be re-applied.

Brass and bronze are beautiful metals but require continual maintenance to retain its luster.

### **Mirror Polished Brass or Bronze**

Mirror polished copper alloys should be periodically cleaned, when it begins to tarnish, with a brass polishing cream that uses low-level abrasives. The liquid or cream polish should be used in accordance with the manufacturer's recommended instructions for safety and use. **Do not** use circular motions when polishing.

### **Satin Polished Brass or Bronze:**

Satin polished copper alloy finishes should be cleaned by rubbing with an abrasive pad such as

[Scotch-Brite General Purpose Hand Pad 7447 by 3M](#), or

[Scotch-Brite Ultra Fine Hand Pad 7448 by 3M](#), or

[Scotch-Brite General Purpose Scrubbing Pad 9650 by 3M](#)

The finish should always be rubbed in the same direction as the grain texture.

### **Satin, Oxidized and Oil Rubbed Bronze:**

*Regularity is the key to a successful maintenance program. A schedule should be arranged providing periodic cleaning with regular inspections in the interim. The schedule should differentiate between interior and exterior surfaces and those surfaces subject to handling, scuffing and abrasion. When a regular maintenance program is followed, most installations can be maintained by oiling or waxing.*

Surfaces pre-finished or naturally weathered to the statuary bronze shades should be maintained by periodic oiling with Lemon Oil, Lemon Grass Oil or high-grade paraffin oil. Oil and wax coatings look best when applied with a well-impregnated, clean soft cloth followed by rubbing with a second, clean soft cloth to remove excess oil or wax.

*Frequency of oiling or waxing is as important as the oil or wax used. Newly installed metal should be oiled weekly for the first month in order to build up a protective film. Metals subject to heavy traffic should be oiled or waxed at one to two-week intervals. Where traffic is moderate to light, monthly treatment may suffice. In non-traffic areas, quarterly or semiannual applications are feasible.*

*Frequency could also be determined when the metal finish appears dull and dry.*

*The frequency of oiling will decrease over time as layers of oil build up to create a protective surface and result in what is known as oil rubbed bronze*

*Considering a typical building entrance, door handles, push plates or bars, and kick plates as well as the door stiles and rails, would normally be exposed to heavy traffic. The doorframe and adjacent window wall framing usually receive less handling and would be considered a moderate to light traffic area. Transoms, canopies and similar metal elements normally out of reach would be classed as non-traffic areas.*

### **Finishes Coated with Clear Baked Enamel or Clear Enamel or Clear Lacquer:**

Finishes coated with a clear baked enamel, clear enamel or clear lacquer coating can be cleaned periodically by gently wiping with a mild soap and water solution, rinsed with clean water and wiped with a clean, dry cloth. No Brass cleaners or polish, no oil or abrasive cleaners or ammonia.

When fingerprints become visible, the coated metal should be wiped with a soft dry or damp cloth as soon as possible.

We do not recommend any protective lacquering of brass and bronze door hardware. Lacquer wears off in certain use areas leaving a non-uniform or spotty finish. The areas most affected are those where the handles contact the metal. Furthermore, rings worn on the fingers can cause the lacquer to be removed thus exposing the scratches of the lacquer. However, protective lacquer will retard aging but not eliminate and will eventually have to be re-done. If proper maintenance is followed, you will be able to elongate the times between refinishing.

## Routine Maintenance

Under normal operating conditions, your DORMA Panic Handle should require no maintenance over the life of the system other than cleaning the bars. However, if you experience difficulty with the operation of the system, please **do not attempt to repair the system yourself**. Please contact the original installer or contact DORMA at (800) 523-8483.

## Repair and Replacements

### Replacing Cylinder

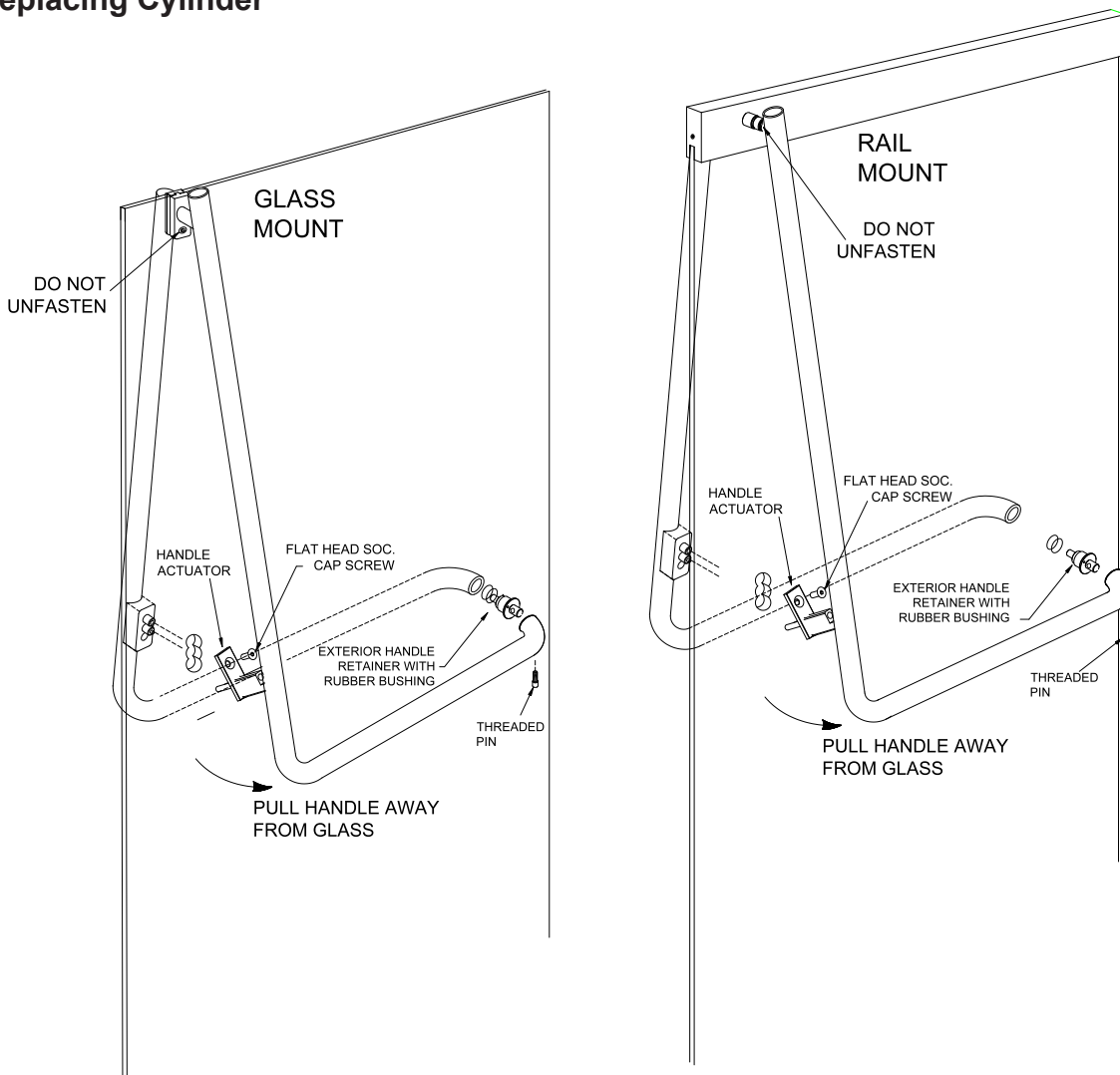

1. Hold on to exterior cylinder housing.
2. Remove flat head socket cap screw.

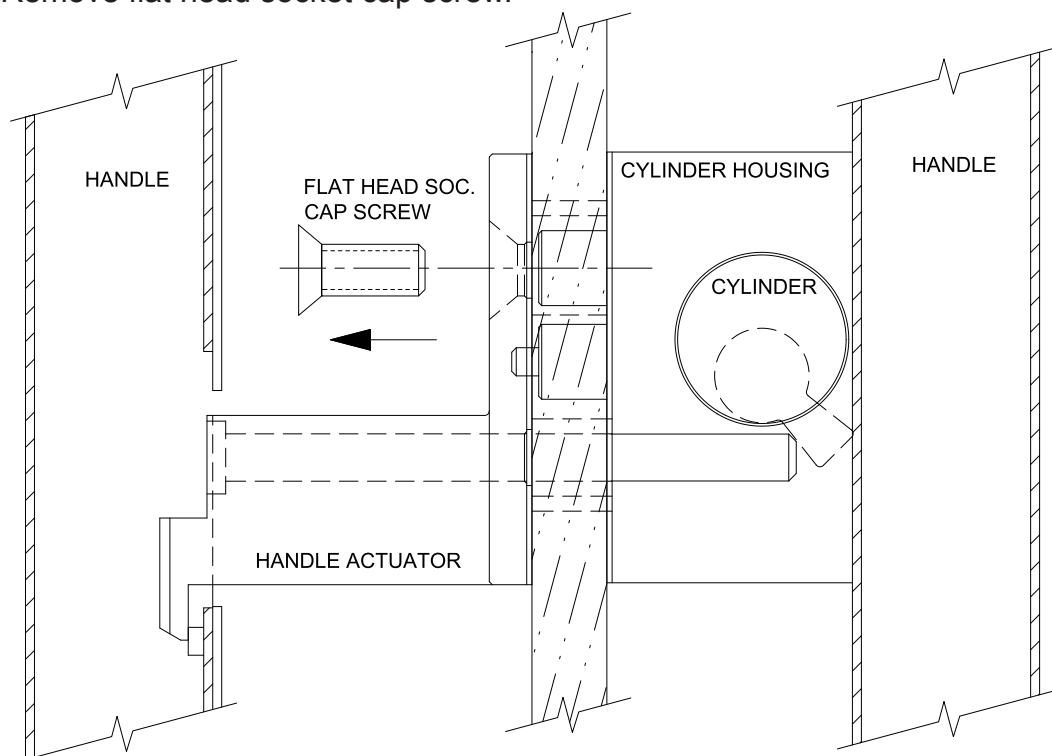

3. Pull handle away from glass. Remove handle actuator from handle.

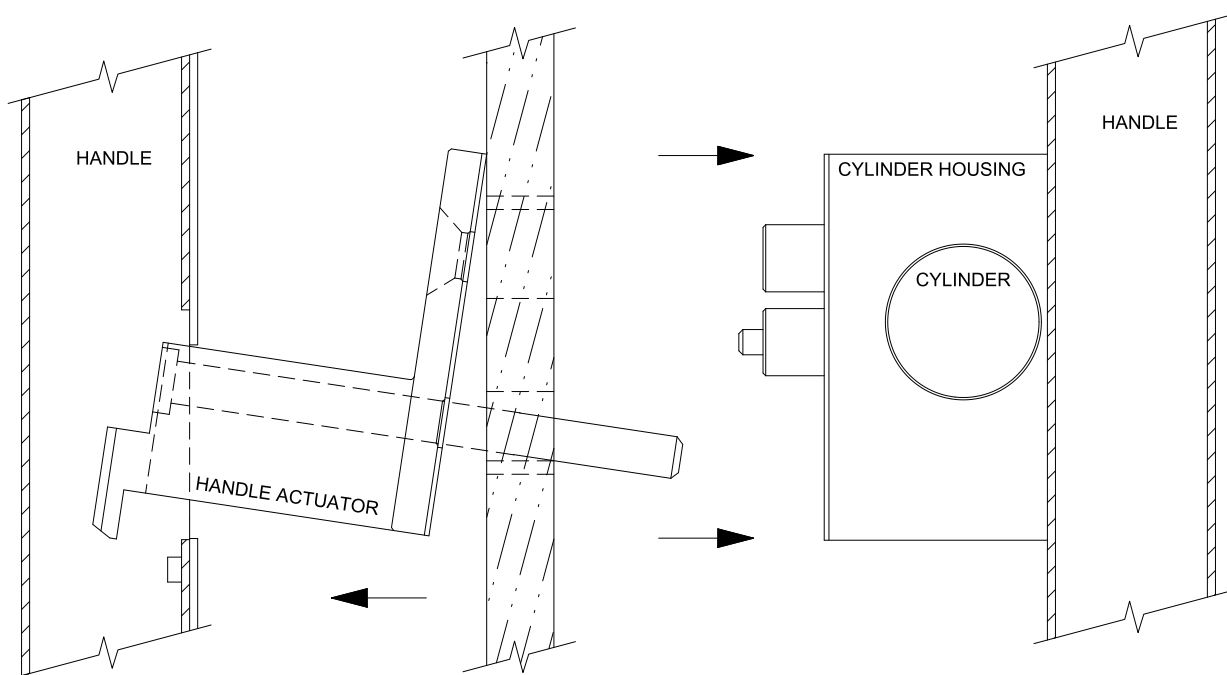

- Loosen set screw holding cylinder in place with an hex wrench.

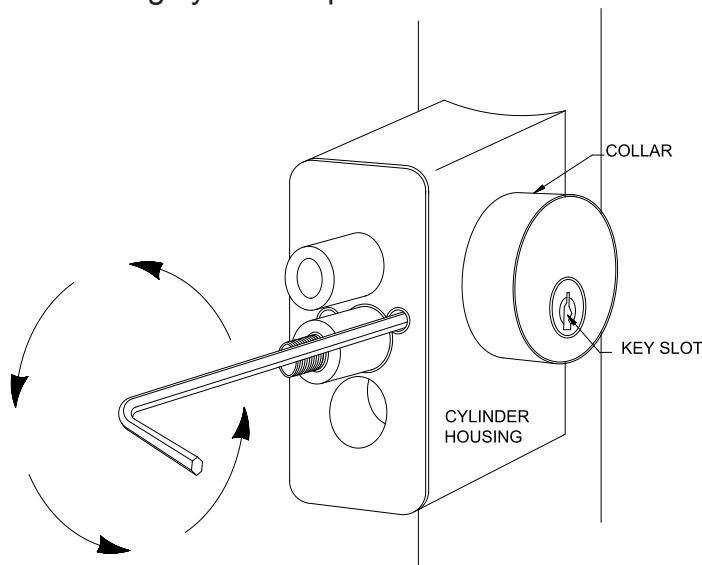

- Remove old cylinder and check to see if tailpiece matches new cylinder tail piece. Also the length of the new cylinder must be the same as the old one. A cylinder of any other length will require a new length collar. Wind in new cylinder until it stops inside the collar ring. Key slot should be on bottom of cylinder nearest the floor.
- To reassemble system, Insert handle actuator into panic handle and place against door (reverse of step 3 on page 6).
- Replace cylinder housing and attach to handle actuator with flat head socket cap screw (reverse of step 2 on page 6).

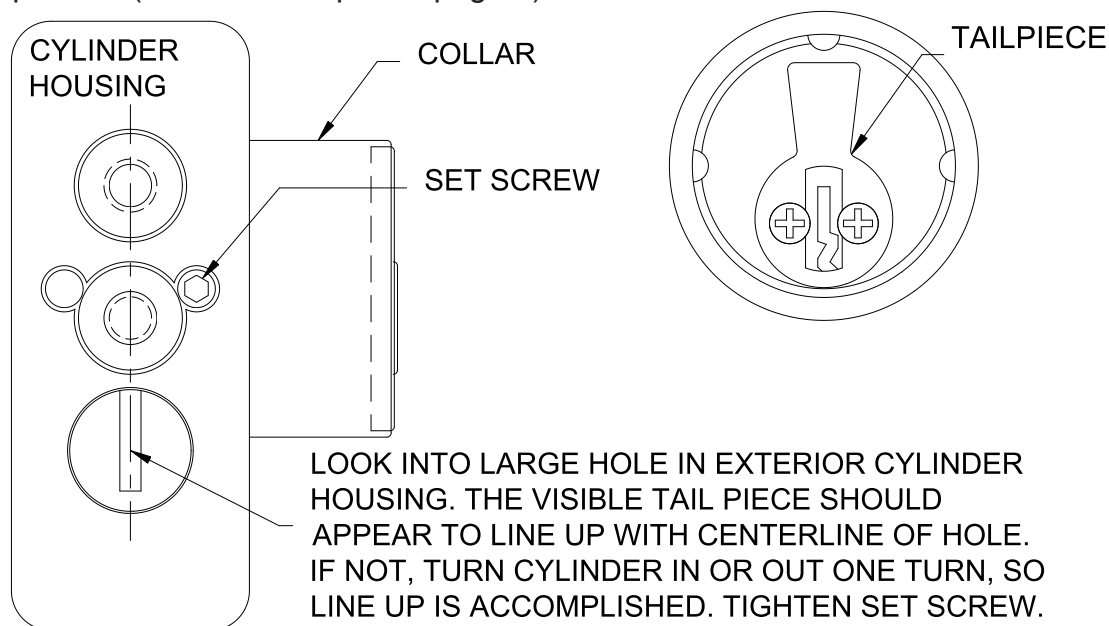

## Repair and Replacements

### Internal Components

1. To access the internal components you must first remove the interior handle from the door. Ref. Instructions in section one (Panic Handle Installation).
2. Lay the handle face down on a non-abrasive surface. Remove and retain the fasteners identified in the diagram below. **Note:** Remove and retain the rubber bumper located under the cover plate at the bottom slot. Use smooth jaw pliers to unscrew the dogging pin.
3. With fasteners removed, slide the internal operator assembly out of the top of the handle. **Note:** To retain current height adjustment, do not rotate top assembly.

