

Integrated emergency power supply

Extension for the ED 100/ED 250

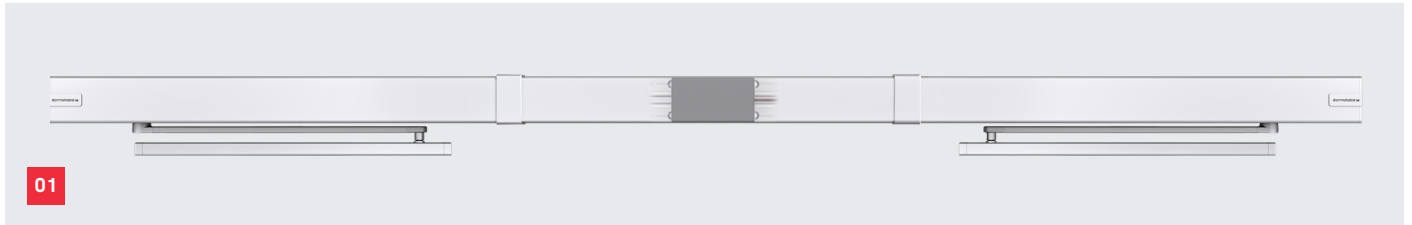

Integrated reliability

This is the strength of the new integrated emergency power supply of the ED 100/250. The integration of the emergency power supply into the housing of the ED 100/250 ensures uninterrupted operation of the operator in the event of a power failure. The emergency power supply can be easily retrofitted to ED operators and is also available for new installations.

Integrated function

The modular structure of the ED system scores not only with its flexibility but also with its simple design. The emergency power supply fits easily into the system as an expandable module and is thus invisible.

- Maintaining the automatic operation in the event of power failure
- Invisible design due to integration
- Easier installation than with an external 230V uninterruptible emergency power supply

01 Version ED 250 for double-leaf door systems with integrated emergency power supply (symbol illustration)

Factsheet

*In Germany, the use of the integrated emergency power supply in combination with hold-open systems is currently not allowed.

Integrated emergency power supply

Versions

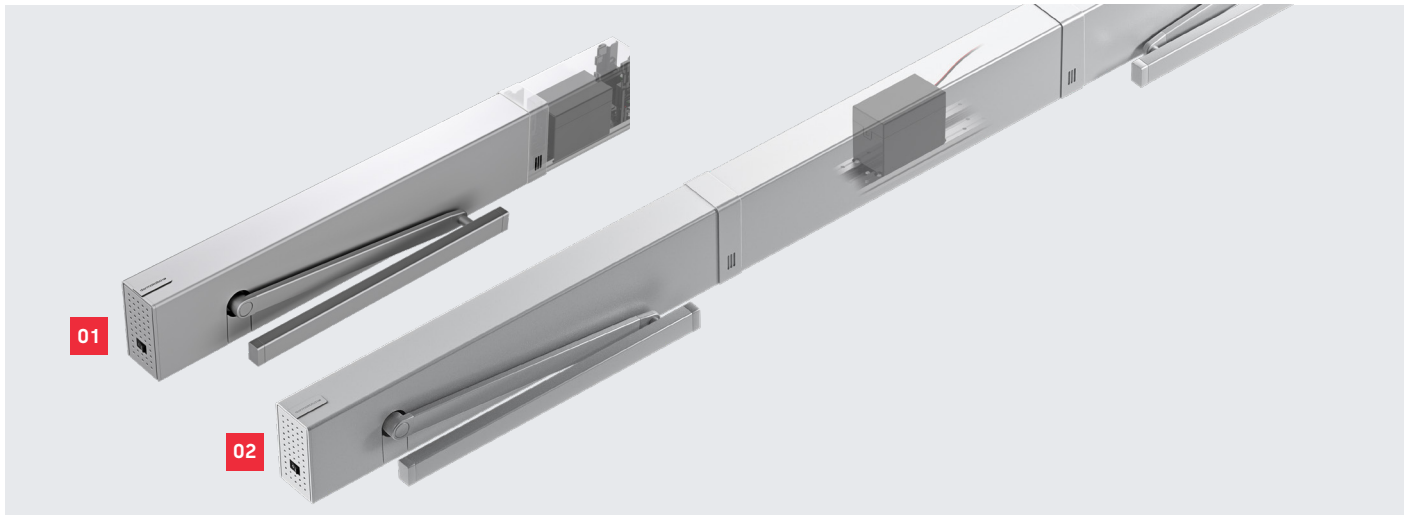

Easy installation and commissioning

The installation of the emergency power supply occurs in the same step as the operator installation for new systems and is integrated in/on the standard cover of the ED with a height of 70 mm. In the case of single-leaf systems, the installation is carried out by means of an attachment kit in the direction of the main closing edge with a length of only 230 mm. The new complete length of the drive is then 915 mm. For double-leaf systems, the installation is carried out centrally under the Vario cover with a required min. hinge distance of 1.630 mm.

Note: Due to the design, a simultaneous function of the integrated emergency power supply with the integrated mechanical door coordinator (ED ESR Set) is currently not possible.

Sustainable & smart reliability

The battery pack consisting of rechargeable lithium iron phosphate batteries (LiFePO₄) has a high capacity, high energy density, a long service life and a significantly higher level of safety. With this battery technology, thermal runaway is almost impossible (compared to lithium polymer batteries). Material like Cobalt is not included. The battery pack can buffer single-leaf systems up to 600 cycles and double-leaf systems up to 300 cycles (depending on the application and connected hardware). The emergency power supply is in stand-by mode for 24 hours in order to take over immediately if required.

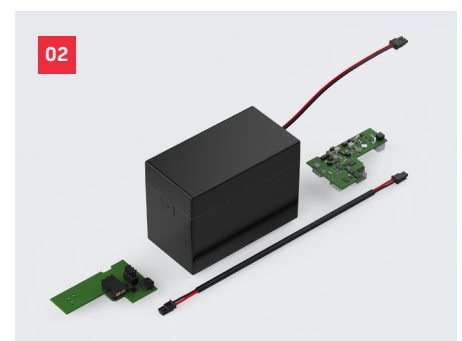
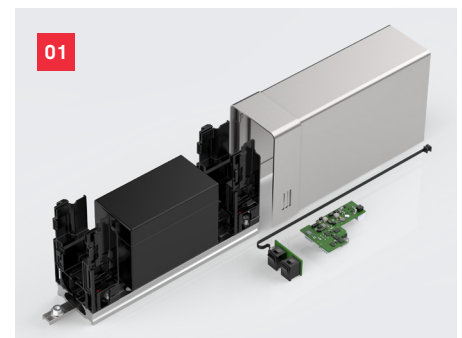

- 01 Set for single-leaf door system
- 02 Set for double-leaf door system

Any questions? We would be happy to advise you.

Contact us on: +41 44 818 90 11