

dormakaba compact reader 91 12



Mobile Access



CardLink



Advantages at a glance

- **Elegant design**
Contemporary, award-winning design with scratch-resistant glass surface
- **Robust and weather-resistant**
Suitable for outdoor use thanks to robust and impermeable design (IP66)
- **Security**
Integrated tamper switch
- **Seamlessly integrated**
Works in online mode, Mobile Access mode or CardLink / AoC
- **Can be retrofitted**
It is possible to use existing wiring and it is easy to replace the existing compact reader using the PIN
- **Secure investment**
Expandable, as it can be combined with a number of dormakaba access systems

Reliable access solution with PIN keypad

Compact reader 91 12 offers an integrated PIN keypad for access systems, providing flexible use for high security requirements.

Award-winning design and elegance

Compact reader 91 12 with elegant high-gloss finish can be integrated harmoniously into existing buildings. The scratch-resistant glass surface, non-wearing keys and complete product portfolio also safeguard your investment in the case of intensive usage over a long operating period.

Flexible integration

Compact reader 91 12 can be integrated into many online dormakaba systems.

Areas of application

Compact reader 91 12 is suitable for access points that require additional PIN verification for security reasons. As it is fully compatible with the existing cabling, it is an ideal way of upgrading older installations.

Compact reader 91 12 fits onto any standard mounting socket and is available in two hardware designs:

- with rear panel and sealing pad for use in protected outdoor areas (concealed wiring) or
- with a spacer frame for use indoors (surface wiring).

Application

- Exterior doors
- Office buildings
- Automatic doors
- Lifts
- Garage doors etc.
- Mobile Access

Intuitive to use

An acoustic signal generator and light symbol (red/green) in the form of a square indicate the access decision to users. Access media are held up to the light symbol. If PIN entry is requested, the keypad will light up. Users are assisted by 'Guide by Light' during this. With Mobile Access, your mobile phone acts as the identification medium and permissions are assigned to the user/mobile phone. The identification process is controlled by a dormakaba app and the LEGIC cloud.

Versatile

For example, with the optional CardLink/AoC it can be used as a validation reader in entrance areas and new temporary authorisations saved directly to the card each day. Indoors, the reader is an ideal solution for spaces that need extra security, such as server rooms or air cargo warehouses.

Assembly

Compact reader 91 12 can be installed on various surfaces, including directly onto metal, in internal and external areas. It is designed for surface cable mounting using a spacer frame and flush cable mounting using a rear panel. As such, the compact reader can be installed directly on concealed mounting sockets and on the wall. A protective frame, which protects against vandalism, is also available.

A universal portfolio

dormakaba's product range includes combinable products that share the same high-quality design.

Note: The products range of available functions depends on the system context in which it is used.

dormakaba compact reader 91 12

Front and rear panel

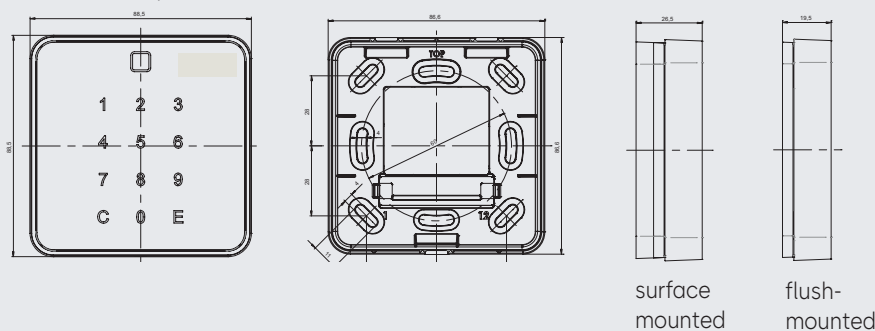

Our Sustainability Commitment

dormakaba is committed to foster a sustainable development along our entire value chain.

In order to give quantified disclosures of a product's environmental impact and its ecological footprint, dormakaba provides Environmental Product Declarations (EPDs). Please download the EPD and read more about our sustainability commitment here or use the QR code provided.



Technical specification

Supported RFID technologies

- LEGIC (advant & prime)
- MIFARE (DESFire & Classic)
- Mobile Access with NFC & BLE

Design / material / dimensions

- Concealed mounting variant UP (rear panel/sealing pad): 88.5 x 88.5 x 19.5 mm (W x H x D)
- Mounting variant AP (spacer frame): 88.5 x 88.5 x 46.5 mm (W x H x D)
- Front: ESG Float glass, Colour: RAL 9005 deep black
- Frame: plastic, Colour: RAL 9006 white aluminium
- Rear panel/spacer frame: plastic, Colour: RAL 9005 deep black

Interfaces

- RS-485: connection to host; galvanically isolated, differential
- two binary inputs: max. 5 VDC
- 1 relay output: max. 34 VDC/60 W, max. 27 VAC/60 VA tamper contact

Power supply

- 12 – 27 VAC, 50/60 Hz or 10 – 34 VDC
- power consumption: max. 3 W

Environmental conditions

- temperature: – 30 °C to +60 °C
- protection type: IP66
- humidity: 5 – 85 %, non condensing

Further details and order information can be found in the relevant dormakaba catalogues or system descriptions.

Subject to change without notice.
© 2025 dormakaba. Version 03/2025



Any questions? We will be happy to assist you.