

# Saflok RT™ Plus

dormakaba 

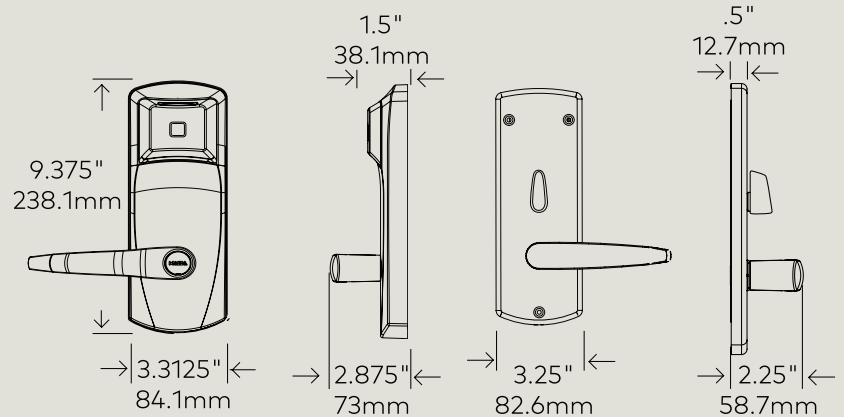

## Overview

dormakaba's RT Plus is an enhanced version of the proven RT RFID electronic lock, offering the BLE technology directly integrated in the reader. Ideal for retrofit, this durable lock is easy to use and works with Ambiance access management software.

## Mobile Access

The lock is mobile access capable with the dormakaba BLE module integrated in the reader.

## Applications

- Suitable for small to very large scale hotels
- Easily replaces existing mechanical or electronic door locks throughout a facility
- Access control for guest rooms, common areas as well as back-of-house
- Easy upgrade path to BLE RFID technology: front housing only or complete lock

## Security Features

- High security and tamperproof design
- 1" solid deadbolt (optional auto deadbolt)
- Staff monitoring (Keycard Audits)
- Emergency access: Emergency keycard, mechanical key

## Low Maintenance

- Batteries last up to 2 years
- Low battery indicator alerts staff
- Lock programming and audit records are not erased during battery replacement
- Operates with a completely sealed contactless reader
- Wear resistant construction and finish
- NFC programming

## Access Management Software

The RT Plus lock is supported by dormakaba's Ambiance access management software that features an array of access control workflows for both guest and staff access. Optionally, choose Ambiance add-on licenses: remote lock management, mobile access solution or enhanced perimeter access

<b>Mechanical Features</b>	
Description	Heavy duty electronic lockset (mortise or cylindrical) with clutch mechanism and built-in contactless RFID reader
Handing	Left or Right factory handed mortise, field reversible handing (lever and mortise)
Lever	ADA compliant, outside lever free to rotate upward and downward in locked mode Lever clearance (space from end of lever to door) Long Lever 3/8" (9.5mm) Short Lever 2" (51mm) Elevon & Gala Levers 2 9/32" (58mm) 
Concealed Key Override (optional)	- Saflok KIK Core (keyed-alike, master keyed, recodable) - Best Small IC Adaptor
Deadbolt	1" (25 mm) (for ASM mortise) or 2 1.4 mm (for ESM Mortise) solid metal, projected by inside thumbturn and retracted with the latch by the interior handle, emergency override or specific staff keycards. Optional auto deadbolt available
Door Thickness	From 1 3/8" to 2 1/2" (35mm to 66mm)
Shipping weight	8.5 lbs (3.8 kg)
Housing Construction	Cast zinc alloy (outside housing levers and thumbturn), stainless steel inside housing
Standard Finishes	Satin chrome, satin brass and supreme finish for ocean front applications
Standard Backset	2 3/4" (70mm) backset, 2 3/8" (60mm) backset also available for cylindrical lock
Locking Options	ANSI lock case with 1 1/4" or 1" lock front mortise Optional automatic deadbolt European lock case mortise (20 x 165 mm) with round (20 or 23 x 235 mm) or square (20 x 235 mm) lock front mortise
Remove Access Management	Ambiance RX: Lock controller board with online capability DAJ mortise (ANSI lock case) Inside escutcheon equipped with Zigbee module
<b>Mobile Access Option</b>	
Stand Alone or BLE enabled	BLE module integrated in the reader
<b>Batteries</b>	
Alkaline - Three AA battery pack	Battery life is up to 2 years Low battery indicator: alerts staff that batteries need to be changed soon
<b>Lock Operation</b>	
Date/Time Stamp	Real-time; date and hours/minutes
Interrogation	Obtain key usage reports from the lock by using a handheld unit at the door, or increase efficiency by performing a remote Interrogation using Ambiance RX (optional)
Pre-registered Keycards	Keys can be made up to ten days in advance without cancelling current or arriving guests
Keycard Expiration	Configurable expiration dates; can be automatically set for check out date or manually applied when making key during check in process.
Passage Mode	Set by authorized keycard or Ambiance RX. Can also be configured to perform an automated/pre-defined passage mode time.
Lockout Mode	Set by authorized keycard or Ambiance RX
Keycards Accepted	Mifare classic: Guest keycards (mini), Staff (4k & 1k) Mifare plus: Guest keycards (Mifare plus 1K, ultralight C), Staff keycards (Mifare plus S 1k, Mifare plus S 2k, Mifare plus S 4k)
Feedback	Light indicators in reader
Diagnostics	Light indicators and handheld display
Audit Trail	Up to 4,000 events
Disability Feature	RCU readers interface with automatic power operated doors for special openings
Privacy Override	Emergency keycards
<b>Certifications &amp; Testing</b>	
Accessibility Standard	Complies with ADA standards 2010 for accessible design
BHMA/ANSI	Certified to be compliant with Grade One performance tests for "ANSI/BHMA A156.13 Standard for Mortise Locks and Latches," and "ANSI/BHMA A156.25 Standard for Electrified Locking Devices."
Fire Rating	Fire certified for Europe EN-1634-1 for 30 minute doors Listed for pre-prepared manufactured doors and certified for retrofitting on existing doors by Underwriters Laboratories for use on fire doors having up to a three-hour rating. a. U.L. Certification: GWVW.R12071 "Accessories for Single-point Locks and Latches and Fire Exit Hardware." Evaluated in accordance with UL 10B and UL 10C. b. U.L. Listing: GYQS.R11247 "Electrically Controlled Single-point Locks and Latches." Evaluated in accordance with UL 10B and UL 10C. c. Also classified in accordance with Uniform Building Code Standard 7-2, "Fire Test of Door Assemblies" (1997)
Electronics	FCC Part 15 Class A and Complies with CE Radio Equipment Directive 2014/53/EU
Environmental Operating Conditions	-31°F to 151°F (-35°C to 66°C) 0% to 85% non-condensing humidity at 86°F (30°C) conditions
Florida Building Code	Approved in the exterior door category (exterior door components). Code of approval is FL13061
<b>Warranty</b>	
Standard Factory Warranty	One year
Support Programs	dormakaba Service Plans (Gold, Silver, Bronze).