

Crane 2000LE and 3000LE

Motion Assist 360

In-ground speed control

Maintenance Manual

RL6001-004 – 07-2022

| EN |

dormakaba 

Table of contents

Table of contents	2
1 General information	2
2 Maintenance	3
2.1 Door and floor maintenance	3
2.2 Weathersweeps	3
2.3 Cleaning surfaces	4
2.4 Center shaft seal maintenance	5
2.5 In-ground speed control	6
2.6 Hanger maintenance	7
2.7 Check breakout force	8
2.7.1 Check bookfold operation	9
2.8 Bearing maintenance, In-ground Motion Assist 360 drive, canopy-mounted bearing	10

1 General information

1.1 Maintenance instructions.

This document contains important instructions for maintenance of Crane 2000LE and 3000LE series manual revolving doors.

1.2 Manual storage.

This document must be kept in a secure place, and accessible for reference as required.
If the door system should be transferred to another facility, insure that this document is transferred as well.

1.3 dormakaba.us website.

Manuals are available for review, download, and printing on the dormakaba.us website.

1.4 Symbols used in these instructions.



WARNING

This symbol warns of hazards which could result in personal injury or threat to health.

NOTICE

Draws attention to important information presented in this document.

CAUTION

Warns of a potentially unsafe procedure or situation.



TIPS AND RECOMMENDATIONS

Clarifies instructions or other information presented in this document.

1.5 Dimensions

Unless otherwise specified, all dimensions are given in inches (").

2 Maintenance

2.1 Door and floor maintenance

Fig. 2.1.1 4 wing revolving door example

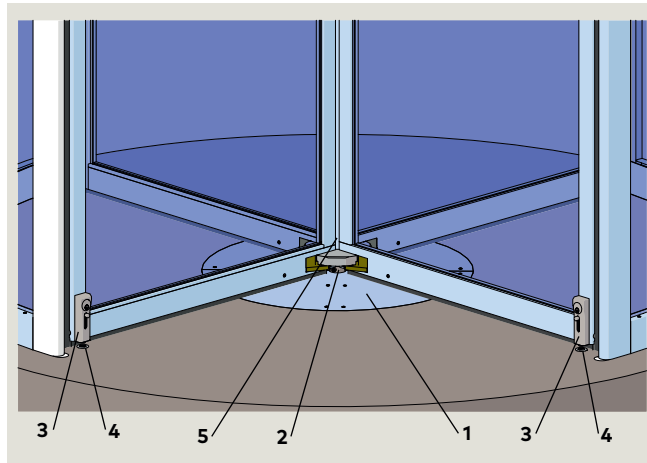

- | | |
|---------------------------------------|----------------|
| 1 Floor cover plate | 4 Floor strike |
| 2 Center shaft bottom
plug adapter | 5 Center shaft |
| 3 Mechanical wing lock | |

2.1.1 Floor maintenance.

1. Keep floor surface clean and free of dirt and debris.

2.1.2 Floor cover plates.

1. Keep floor cover plates free of dirt and debris.
2. Check floor cover plate fasteners for tightness.
 - Hand tighten fasteners with Phillips screwdriver.
3. Clean any debris present at the center shaft bottom plug hole in cover plates.

2.1.3 Mechanical wing lock and floor strikes.

- Keep wing locks and floor strikes free of dirt and debris.

2.1.4 Door glass maintenance.

1. Clean all glass surfaces with commercially available glass cleaners.

2.2 Weathersweeps

Fig. 2.2.1 T-style weathersweep

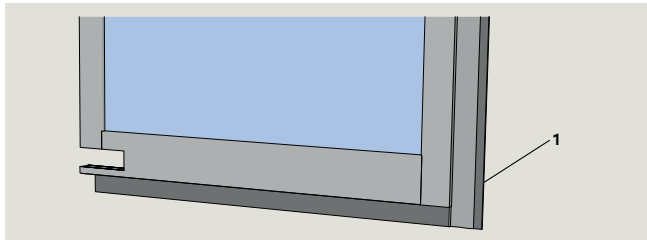

- 1 T-style weathersweep

Fig. 2.2.2 Horsehair weathersweep

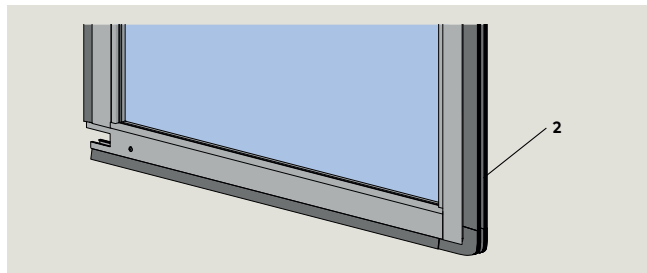

- 2 Horsehair weathersweep

2.2.1 Weathersweep maintenance.

NOTICE

Reducing or trimming the size of the bottom sweep makes the sweep more rigid and voids all warranties.

1. Inspect condition of sweeps.
 - Recondition horsehair sweeps if possible using conditioner.
2. Replace weathersweeps as required.
 - Contact Crane for replacement weathersweeps.

2.3 Cleaning surfaces

2.3.1 Aluminum

1. Dust and grime can be removed by regular cleaning.
 - Use a mild, non-abrasive soap or cleaning solution and water.
 - After cleaning, surfaces should be wiped dry with a clean absorbent material.
2. Tar and built-up dirt can be removed with solvent cleaners such as turpentine if followed by a soap and water cleaning and fresh water rinse.

NOTICE

Avoid acid or alkali cleaners; they may attack the anodized finish.

- After cleaning, surfaces should be wiped dry with a clean absorbent material.

2.3.2 #4 stainless steel

1. For routine cleaning, use soap, ammonia, or detergent and water.
 - Always working in the direction of the grain, rub with a sponge or rag.
 - Rinse with water, wipe dry.
2. Stubborn dirt or grime can be removed with a quality commercial stainless steel cleaner.

2.3.3 Mirror finish stainless steel

NOTICE

Mirror finishes require very special care. Abrasive cleaners and cloths should never be used.

1. Use only mild soap and water or glass cleaner.
 - After cleaning, surfaces should be wiped dry with a clean absorbent material.

2.3.4 Bronze

NOTICE

To insure proper maintenance, consult a professional bronze finisher and establish a regular metal cleaning program.

1. Bronze finishes are protected during shipping and installation by a shop coat of lacquer.

NOTICE

Lacquer can be damaged by ammonia in window cleaners, or by acids from masonry cleaners. Protect doors from these cleaners.

NOTICE

Doors must be inspected and worked after installation by a qualified bronze finisher.

2.3.5 Painted finishes

1. Any mild non-abrasive soap or mild solvent can be used for cleaning.

NOTICE

Strong solvents may dissolve paint. Test any solvent first.

2. Wax can be used to protect the finish.

2.4 Center shaft seal maintenance

Fig. 2.4.1 In-ground container floor cover plates

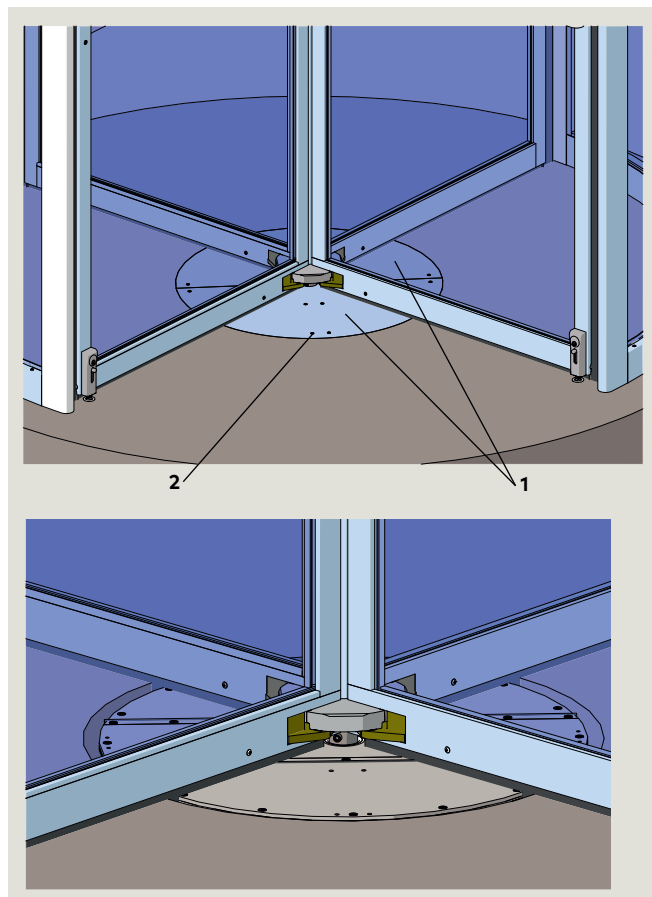

- | | |
|-------------------------------|---|
| 1 Floor cover plate
RC6048 | 2 10-32 x 3/8" sealing
flat head screw, SS
RF6026-01G |
|-------------------------------|---|

Fig. 2.4.2 Shaft seal

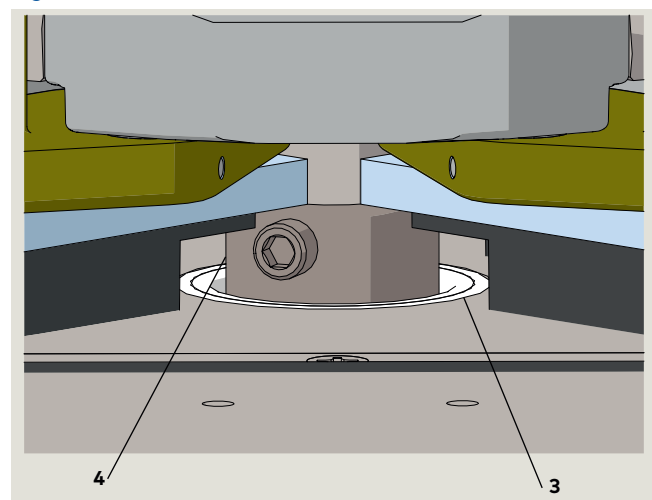

- | |
|-------------------------|
| 3 Shaft seal
RC6041 |
| 4 Bottom plug
RC6083 |

NOTICE

Place Mode switch in OFF position before performing maintenance.

2.4.1 Clean floor cover plates and center shaft opening.

1. Clean floor cover plates as required to keep plates free of debris.
2. Check center shaft opening for debris and clean as required.

2.4.2 Check shaft seal every six months.

NOTICE

Importance of checking the shaft seal.

Shaft seal prevents foreign objects, debris or moisture from entering at the bottom plug entrance to the in-ground container.

If damage is observed, shaft seal must be replaced.

1. Remove the 10-32 x 3/8" sealing flat head screws (2) that secure the floor cover plates to the in ground container.
2. Remove the two floor cover plates.
3. Check the shaft seal for any damage.
 - Cracks
 - Wear
 - Breaks
 - Other damage or debris accumulation.

NOTICE

If damage is observed, shaft seal must be replaced.

- 4.. Replace floor cover plates and secure with 10-32 x 3/8" sealing flat head screws.

2.4.3 Shaft seal replacement.

1. Replace shaft seal if physically damaged (Para. 2.4.2).
2. Shaft seal replacement recommendation:
 - Every two years as a minimum.
3. Shaft seal replacement will require wing and center shaft removal.

2.5 In-ground speed control

2.5.1 Maximum allowable door RPM

Maximum inside diameter	6 ft, 6 in. [1980 mm]	7 ft [2135 mm]	7 ft, 6 in. [2285]	8 ft [2438 mm]	8 ft, 6 in. [2590 mm]	9 ft [2745 mm]	9 ft, 6 in. [2895]	10 ft [3050 mm]
Manual speed control RPM	12	11	11	10	9	9	8	8
Time for one door revolution (s)	5	5.5	5.5	6	6.7	6.7	7.5	7.5

Fig. 2.5.1 Manual speed control, cover removed

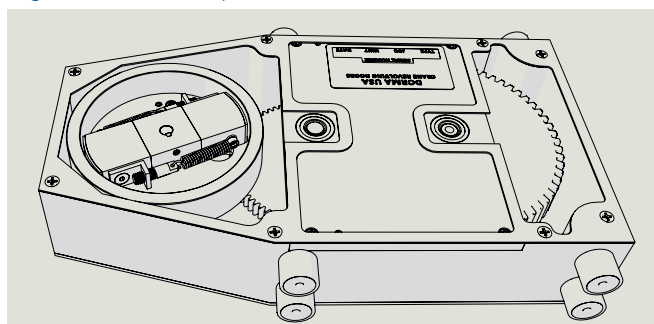
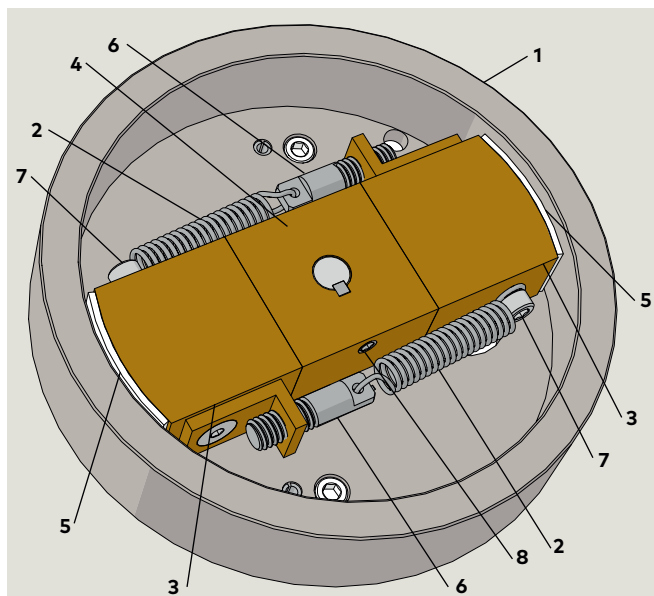

Fig. 2.5.2 Brake housing assembly



- | | |
|--------------------------------|-----------------------------------|
| 1 Brake housing assembly | 5 Brake shoe |
| 2 Brake spring | 6 Brake screw |
| 3 Left-right brake shoe holder | 7 10-25 x 1/2" SHCS |
| 4 Center brake block | 8 .25-20 .50" cup point set screw |

CAUTION

In-ground speed control maintenance should only be done by trained dormakaba service personnel.

2.5.2 Adjust brake engaging pressure.

- Increase tension on brake springs:
 - Remove SHCS (7) securing brake spring to brake shoe holder.
 - Turn brake screw (6) CW to increase spring tension.
 - Reinstall SHCS.
 - Repeat for second brake spring.

2.5.3 Replacement of brake shoes.

- Remove center brake block/left-right brake shoe holder assembly to replace brake shoes.

2.6 Hanger maintenance

Fig. 2.6.1 4 wing door assembly example

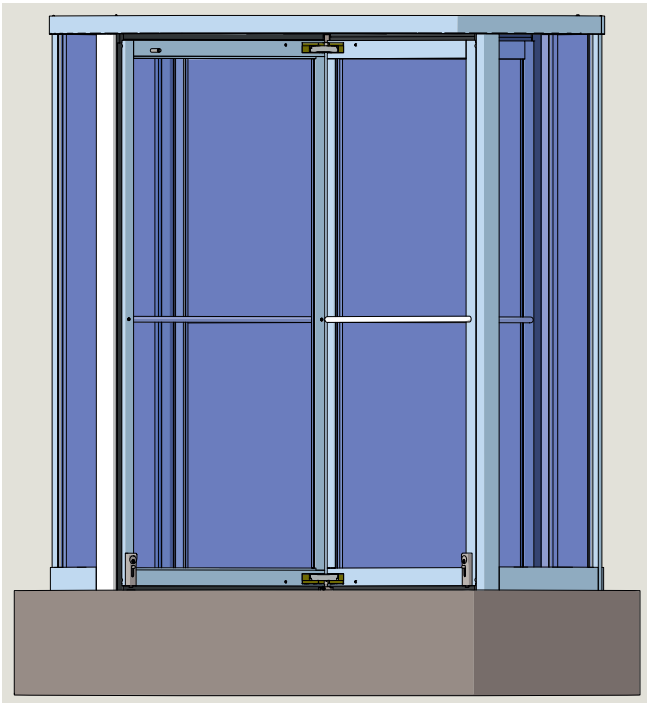
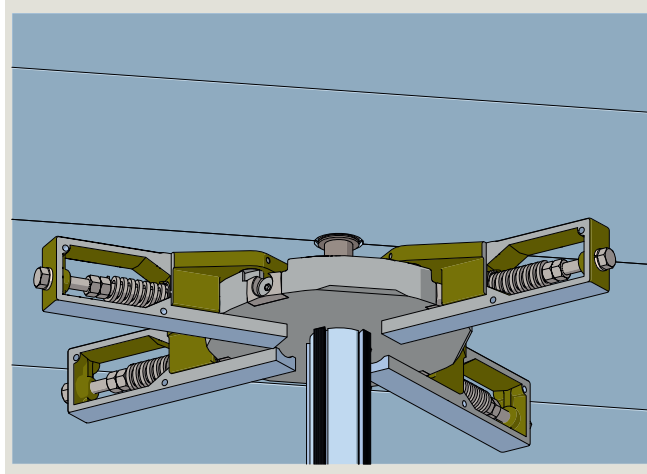

Fig. 2.6.2 4 wing door center shaft hangers



2.6.1 Hanger / hanger disc maintenance.



TIPS AND RECOMMENDATIONS

Bookfold wings for the following procedures.

1. Check for dirt and debris and clean as required at.
 - Hanger assemblies.
 - Hanger disc assemblies.
2. Check for lubrication on hanger disc and at hangers.
 - Lubricate as necessary.

2.7 Check breakout force

Fig. 2.71 Wing in bookfold position

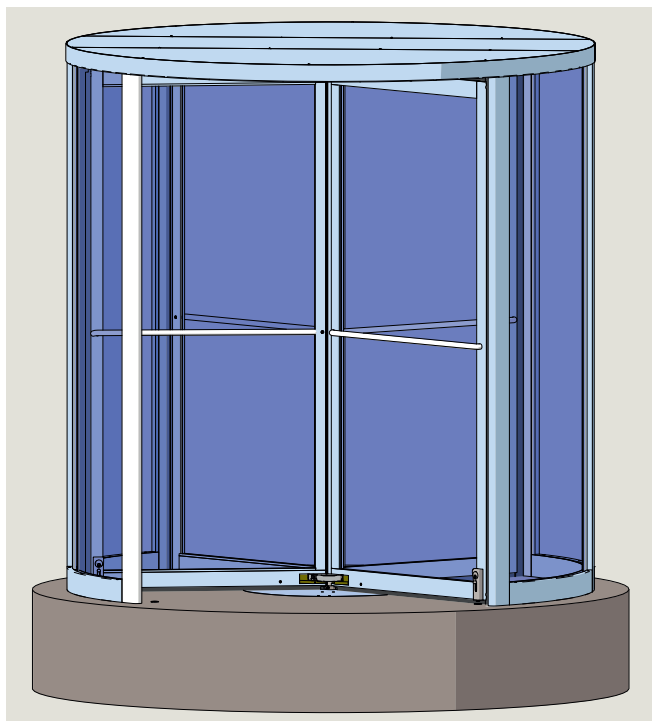
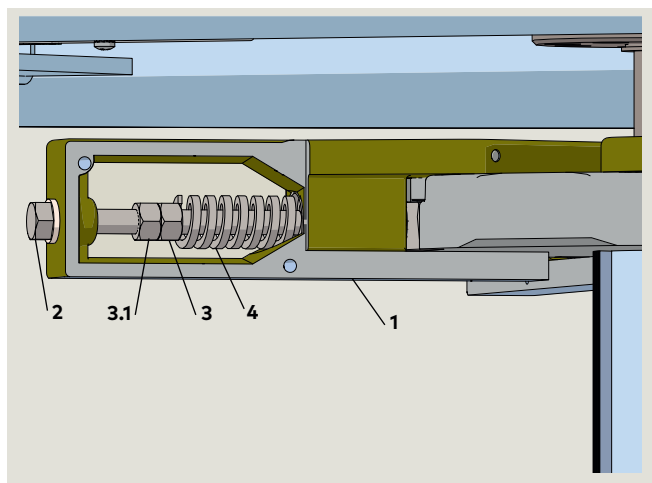

Fig. 2.7.2 Hanger tension adjustment



- | | |
|------------------------------------|--------------------|
| 1 Hanger assembly
RS6045-020 | 3 .375-16 hex nut |
| 2 Hex bolt, .375x 4"
RC6156-01G | 3.1 375-16 hex nut |
| | 4 .Spring |

2.7.1 Breakout force.

Set breakout force based on prevailing conditions at the door opening.

NOTICE

ANSI/BHMA A156.27

Para. 10 Breakout force requirements.

Each revolving door wing shall be capable of breakout when a force of not more than 130 lb. [578 N] is applied at a point 3 inches [76 mm] from the outer edge of the outer wing stile and 40 inches above the floor.

2.7.2 Check breakout force on first wing.

1. Block one door wing. Push an adjacent wing with a force gauge until breakout occurs. Note breakout force.
2. If hanger breakout force adjustment is required, refer to Para. 2.7.3.

2.7.3 Hanger breakout force adjustment.

1. Remove wing from hangers.



WARNING

Use caution handling wing assemblies!

- Use open end 9/16" box wrench for tension adjustment.
 - Monitor number of hex nut turn adjustments made so that the same number of adjustments can be made on the lower hanger.
 - **Increase hanger tension:**
 - Turn hex nut (6) CW to tension spring.
 - Use two 9/16" wrenches to both lock hex nuts in place.
 - Repeat same tension adjustment on lower hanger.
 - **Decrease hanger tension:**
 - Turn hex nut 6.1 CCW to allow reduced tension adjustment.
 - Turn hex nut (6) CCW to reduce decrease tension on spring.
 - Use two 9/16" wrenches to both lock hex nuts in place.
 - Repeat same tension adjustment on lower hanger.
2. Reinstall wing and repeat breakout force test.
 3. Repeat tension adjustment until breakout force requirements in Para. 7.1.1 are met.

Fig. 2.7.4 Door wing in breakout position

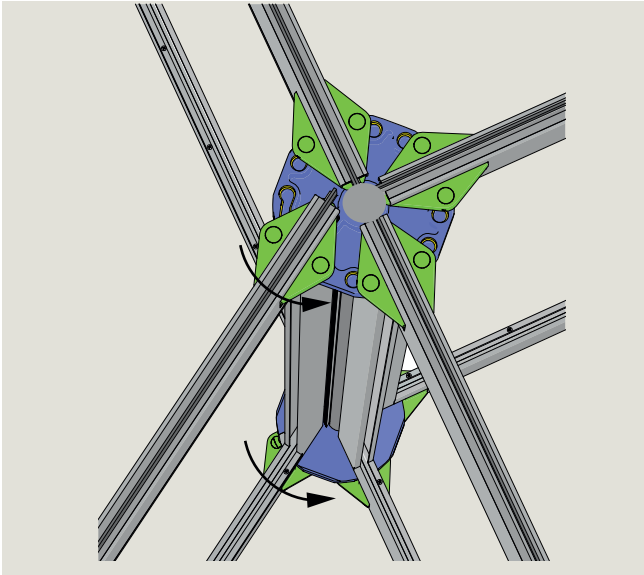

2.7.4 Breakout force, remaining wings.

1. Check breakout force on each of the remaining wings.
2. Adjust breakout force as required on each wing to meet requirements in Para. 2.7.1.

2.7.1 Check bookfold operation

Fig. 2.7.1.1 Door wings in bookfold position

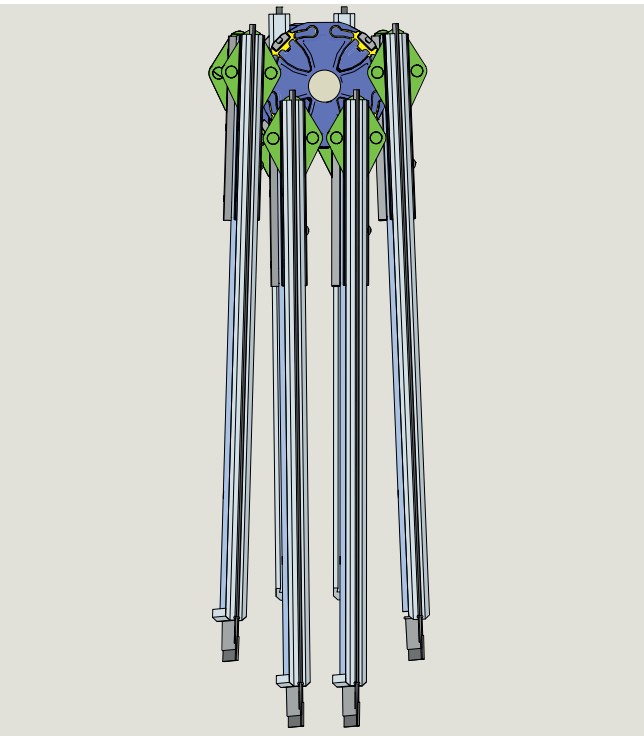

2.7.1.1 Check wing bookfold operation

1. Check bookfold operation on all wings.

2.8 Bearing maintenance, In-ground Motion Assist 360 drive, canopy-mounted bearing

Fig. 2.8.1 Canopy-mounted bearing assembly

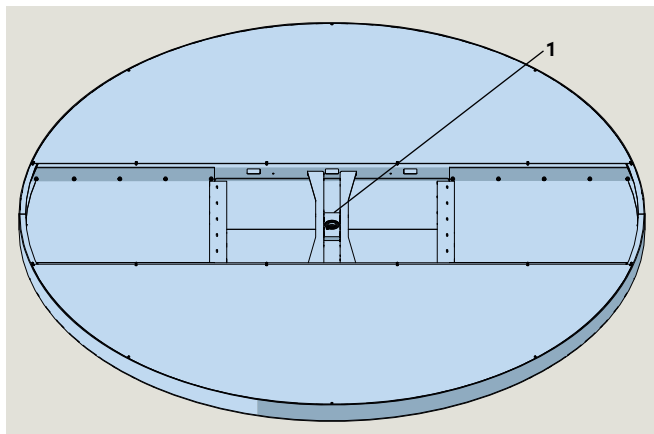

1 Bearing assembly

2.8.1 Check for bearing wear from top of canopy.

1. Top of canopy access to bearing assembly.

NOTICE

Use caution working in top of canopy area.

2. Remove center cover.
3. Check bearing assembly for signs of wear.
4. Manually rotate door and check for bearing wear.
5. **Replace bearing assembly if bearing wear is present.**

Fig. 2.8.2 Bearing bracket assembly RS6064

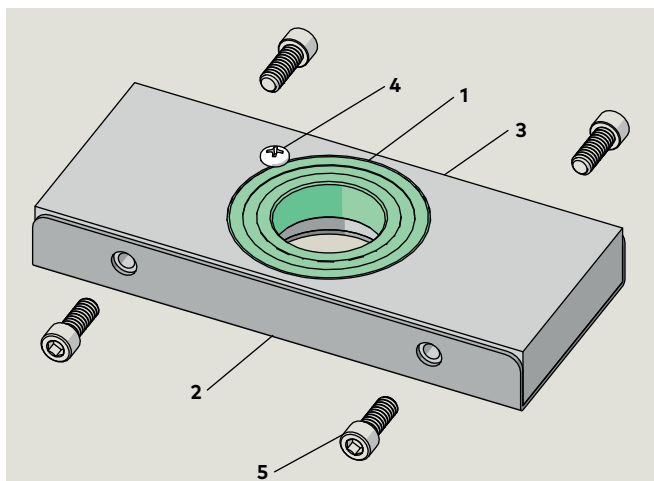

- | | |
|---|----------------------------------|
| 1 Ball bearing
RF6109-01G | 3 Bearing mounting
RC6234-010 |
| 2 Bearing canopy
bracket
RC6244-010 | 4 8-32 x 1/2" Phillips
screw |
| | 5 1/4-20 x 5/8" SHMS |

Fig. 1.8.3 Bearing assembly

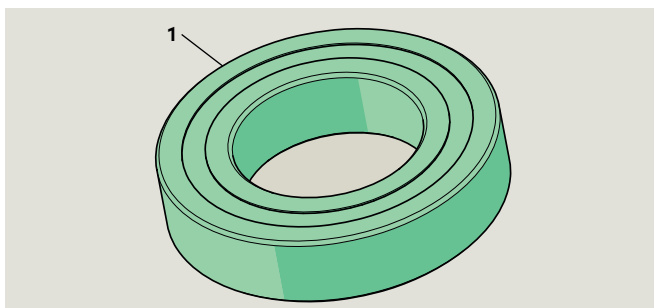

1 Ball bearing
RF6109-01G

This page left intentionally blank.

www.dormakaba.us

dormakaba USA, Inc.
1 Dorma Drive, Drawer AC
Reamstown, PA 17567
USA
T: 717-336-3881
F: 717-336-2106