

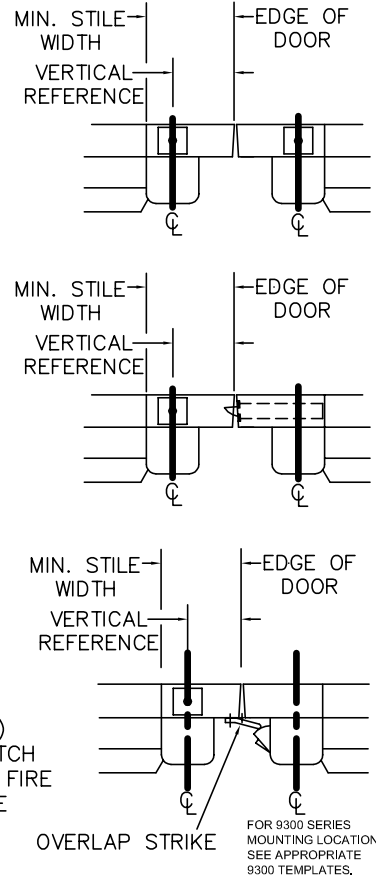

RHR SHOWN
LHR OPPOSITE

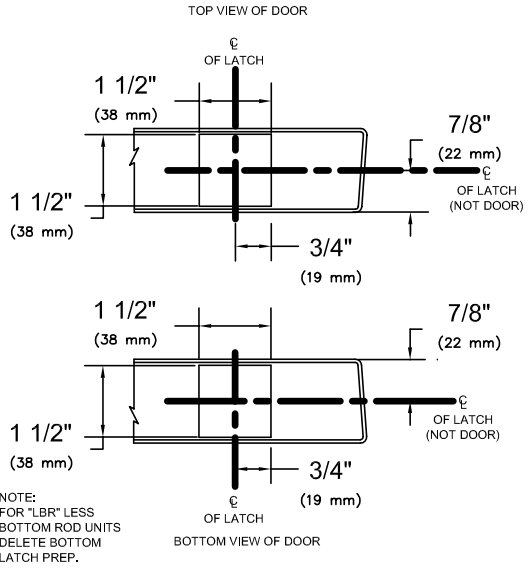
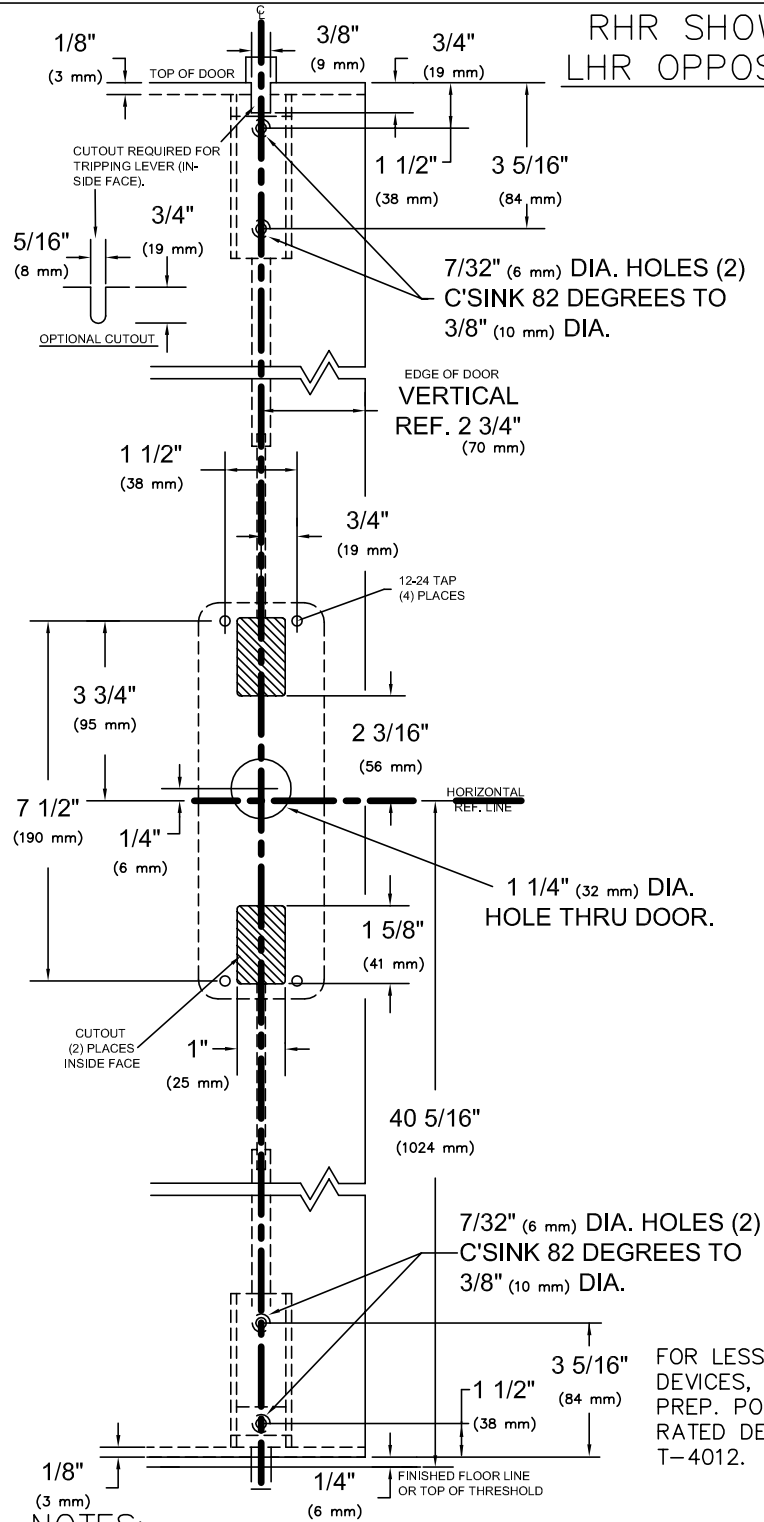

NOTES:

1. SEE MASTER SHEET #T-0001 FOR SUGGESTED DOOR REINFORCEMENT.
2. SEE ADDITIONAL TRIM TEMPLATE WHEN REQUIRED.
3. DEVICE WILL COVER STANDARD SDI CUTOUT.

VERTICAL REFERENCE	MINIMUM STILE WIDTH
2 3/4" (70 mm)	4 3/16" (106 mm)

REV. No. 3	REVISION: Add Note	DATE: 3-18-03
 <p>9100 & F9100 x CYLINDER (NO TRIM) VERTICAL ROD EXIT DEVICE (Aluminum Door) (For Use With Optional ALD Brackets)</p>		<p>TEMPLATE NUMBER T-9131AL ③</p>

RHR SHOWN
LHR OPPOSITE

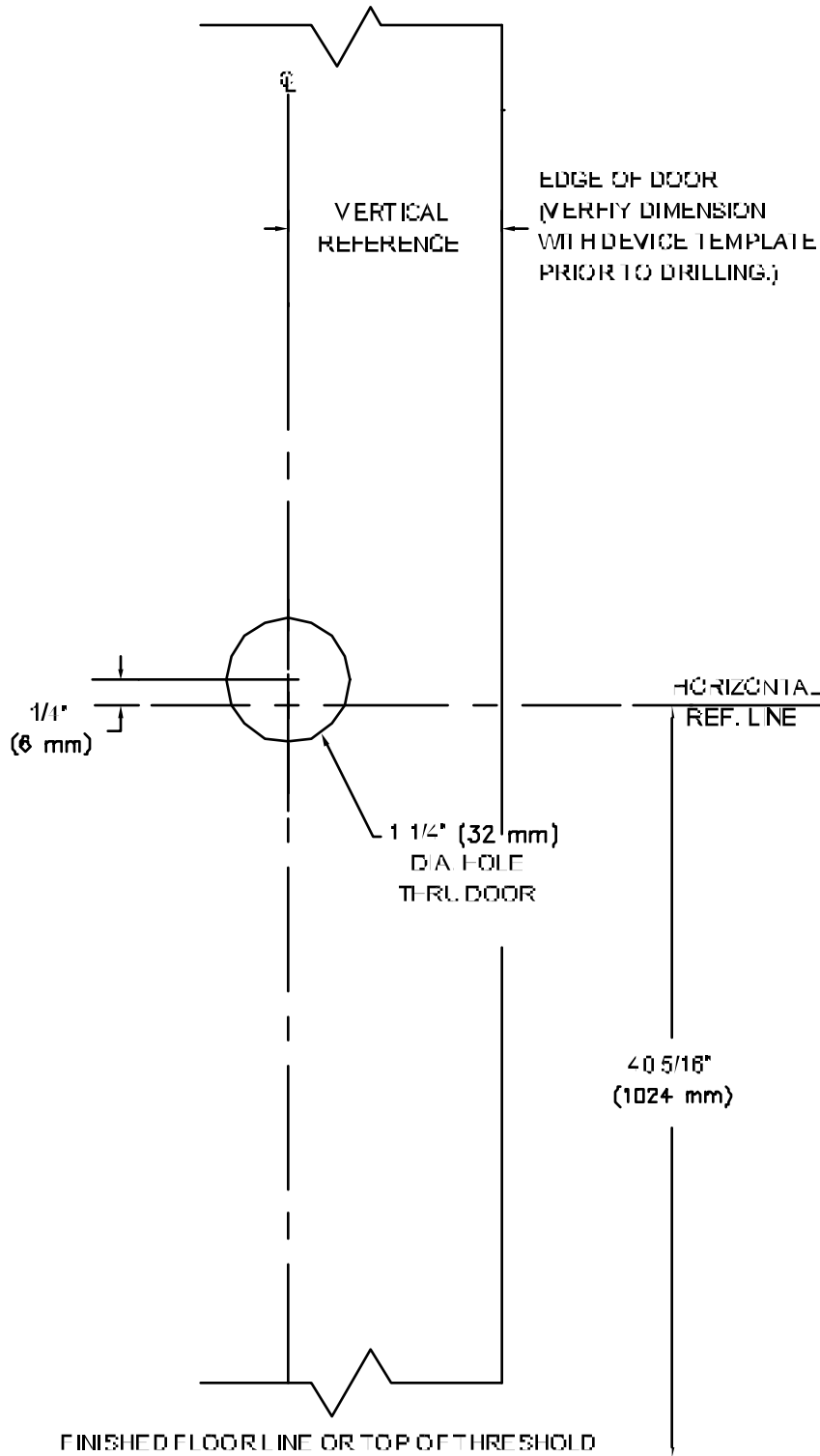

NOTES:

FINISHED FLOORLINE OR TOP OF THRESHOLD

1. SEE MASTER SHEET #T-0001 FOR SUGGESTED DOOR REINFORCEMENT.
2. SEE ADDITIONAL DEVICE TEMPLATE WHEN REQUIRED.

REV. No. 1

REVISION: ADD NEW BORDER

DATE: 4-25-00



CYLINDER ONLY (NO TRIM)

TEMPLATE NUMBER
T-9002 ①