

EMSL-2700 SERIES SHEAR LOCKS



INSTALLATION INSTRUCTIONS EMSL-2700 SERIES

REFER TO APPROPRIATE TEMPLATE ACCORDING TO THE TYPE OF DOOR AND FRAME APPLICATION.

READ INSTRUCTIONS AND STUDY THE TEMPLATE THOROUGHLY BEFORE BEGINNING THE INSTALLATION.

IMPORTANT NOTES:

- Although electromagnetic shear locks provide the utmost in aesthetics for fail-safe applications, they are less forgiving than direct pull magnetic locks where alignment problems exist. Great care must be taken during preparation and installation of the frame, door hardware and the EMSL-2700 to attain proper alignment and insure positive lock operation.
- Unbalanced air conditioning (stack pressure) can hinder door alignment and must be corrected to help insure positive locking.
- Use GRADE 1 door closers only.
- POSITIVE CENTERING DOOR CLOSER ONLY should be use on double acting doors to help attain consistent dead center alignment.
- Door latching problems must be corrected prior to installation.

INSTALLATION:

1. Clearance between the top of the door and frame header must be 1/8". Make adjustments to the door as required.
2. Adjust single acting door and door closer to insure the door settles immediately and is fully closed and at rest against the stop allowing for silencers, smoke seals or weather stripping where applicable.

Adjust double acting door and POSITIVE CENTERING DOOR CLOSER to insure the door settles immediately and is fully closed and at rest in the dead center of the frame.

3. Locate the vertical centerline of the EMSL-2700 and armature as close as possible to the leading (latch) of the door edge.

CAUTION: Wood door applications require the armature back box to be located an ample distance from the door edge vertical grains, to avoid splitting from wood screws.

4. Determine the horizontal centerline of the door top rail thickness. The armature centerline will be the same.
Mark the door per the appropriate template attached.
5. Before determining the frame header centerline single acting doors must be fully closed and at rest against the stop allowing for silencers, smoke seals or weather stripping where applicable. Double doors must be fully closed and at rest in the dead rest in the center of the frame.

Determine the frame centerline by transferring the door top rail horizontal centerline to the frame.
See Figure 1.

6. Mark the header per the appropriate template attached.
7. Prepare the door and frame per the appropriate template attached.
8. The shear locks may be wired to one of two different electrical configurations. An auto relock time delay (standard with 2765) is recommended for all installations to delay relocking 1 to 6 seconds after the door is initially closed. This will help insure the door is fully closed and at rest to obtain optimum alignment before the shear lock is energized. Consult Figure 7 (Fig. A or B) according to material supplied.
9. When installing 2766 model use Figure B, make the timer adjustment as required and test the TDA time delay prior to mounting in the frame. The TDA timer is field adjustable for 1 to 6 seconds and is factory set at approximately 3 seconds. Turn clockwise to increase and counter clockwise to decrease the delay time.
10. Install the shear locks and armature with the auto relock switch assembly towards the leading (latch) edge of the door.
11. For proper operation the armature must be adjusted up as close as possible and parallel to the shear lock without interfering with opening and closing of the door. Proper operation cannot be expected with more than 1/8" clearance between the armature and the shear lock. Use the hex key provided to adjust the armature vertical adjustment screw (the hex head screws centered at both ends of the armature assembly). Turn counter clockwise to raise the armature.
12. With the door closed turn the lock power on. Check the lateral alignment. The armature shear stops should be centered between each pair of magnet shear stops.
13. If the clearance between the the shear stops is sufficient, open and close the door a few times to insure the shear lock will lock and unlock positively.
14. Adjust the auto relock switch magnet to avoid early activation and help insure positive locking when door is closed. Adjust clockwise to delay shear lock activation. **Do not** adjust higher than the armature rest position.
15. To make shear lock 2765 Figure 7 (Fig. A) timer adjustment, remove the hex set screw in the shear lock face. Replace set screw after adjustment.
16. If the shear stops are to close or binding, double check the templating and door alignment, and make corrections as required.
17. If positive locking cannot be attained due to misalignment after the previous adjustments, the armature shear stops can be reversed with the wide clearance shear stops.

CAUTION: The use of armature offset shear stops may correct misalignment but should not be used when proper door latching is inhibited.

18. Repeat steps 11 to 15 as necessary following shear stop replacement.
19. Cycle the door and shear lock several times after the completion of installation.

MODEL #	LOCK DIMENSION			HOLDING FORCE	POWER CONSUMPTION		MODEL#	ARMATURE DIMENSION		
	L	W	D		12VDC	24VDC		L	W	D
2765	10 7/16"	1 1/2"	1 5/8"	2700	800mA	400mA	ALHMC	11"	1 1/2"	7/8"
							FC	11"	1 1/2"	7/8"
2766	10 7/16"	1 1/2"	1 1/4"	2700	800mA	400mA	HC	11"	1 1/2"	7/8"

FIGURE 1

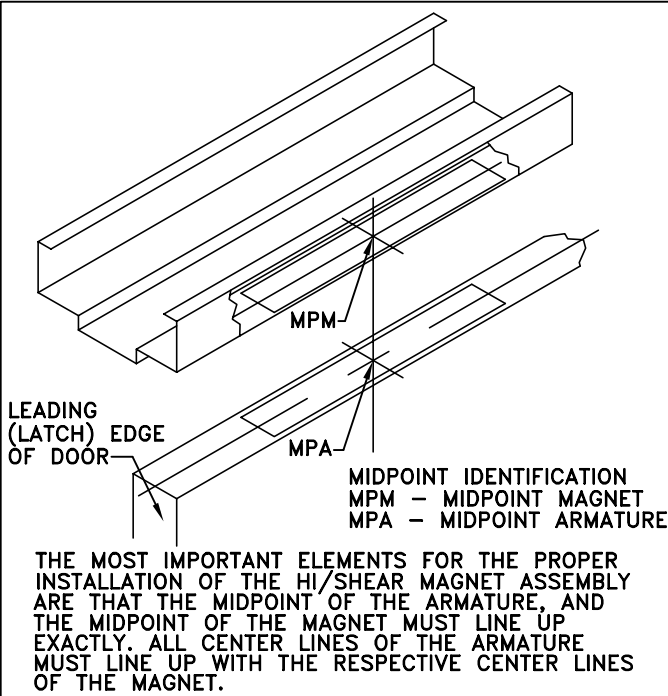
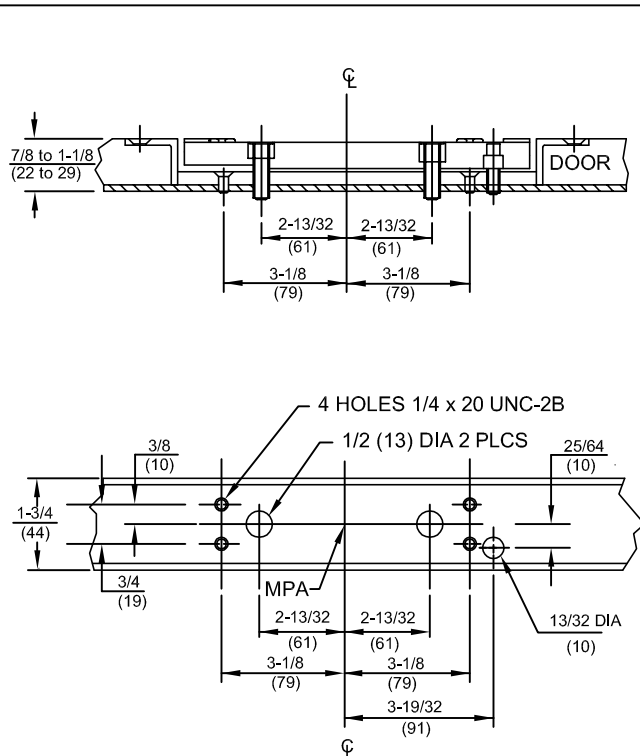

FIGURE 3



METAL DOOR TEMPLATE
7/8 (22) TO 1-1/8" (29) DEPTH CHANNEL

FIGURE 2

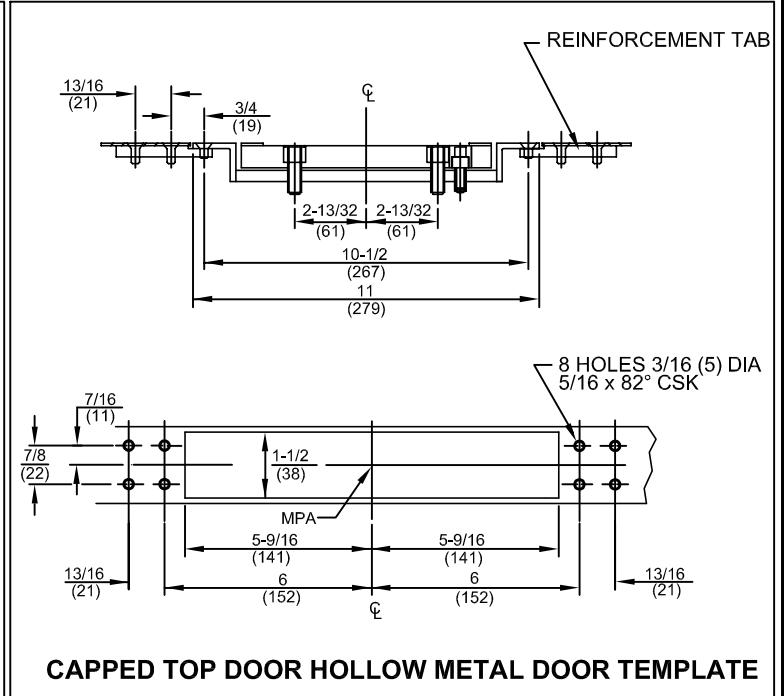
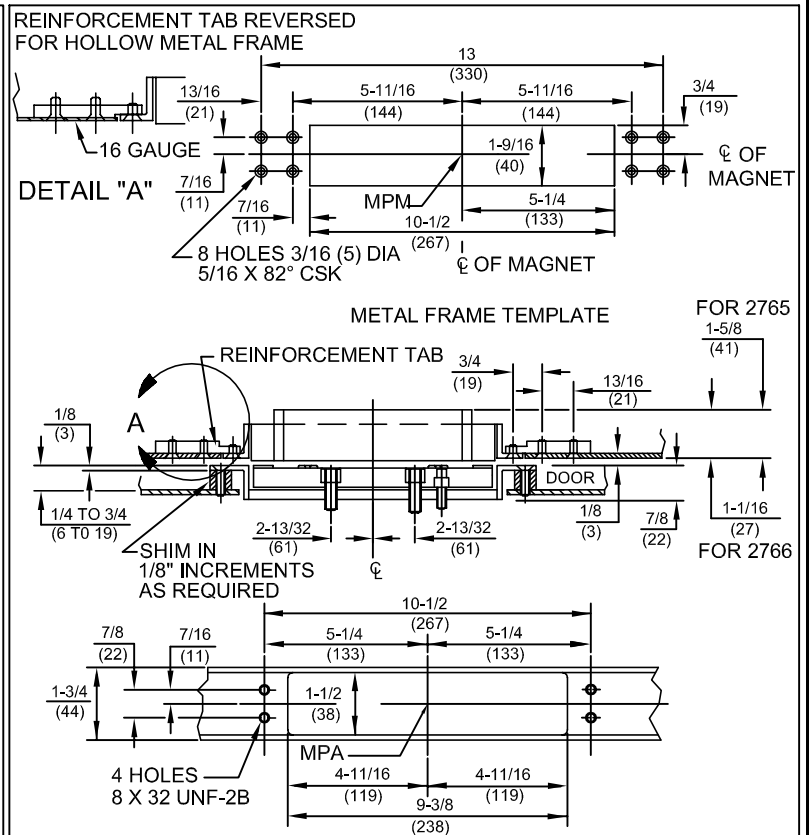

FIGURE 4



METAL DOOR TEMPLATE
1/4 (6) TO 3/4" (19) DEPTH CHANNEL

FIGURE 5

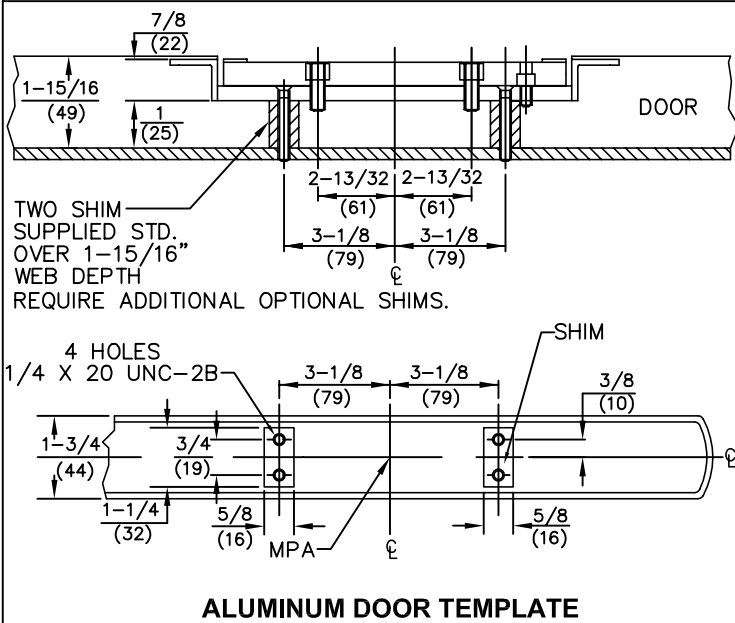

FIGURE 6

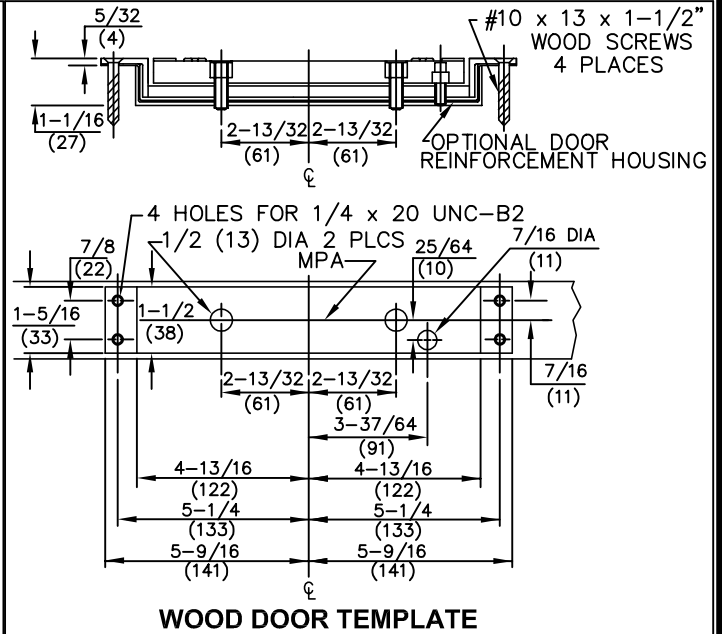

FIGURE 7

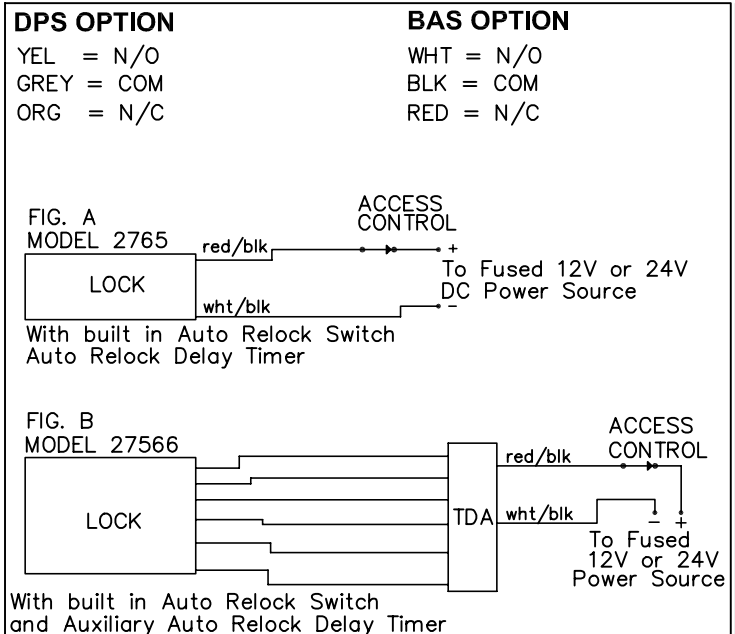
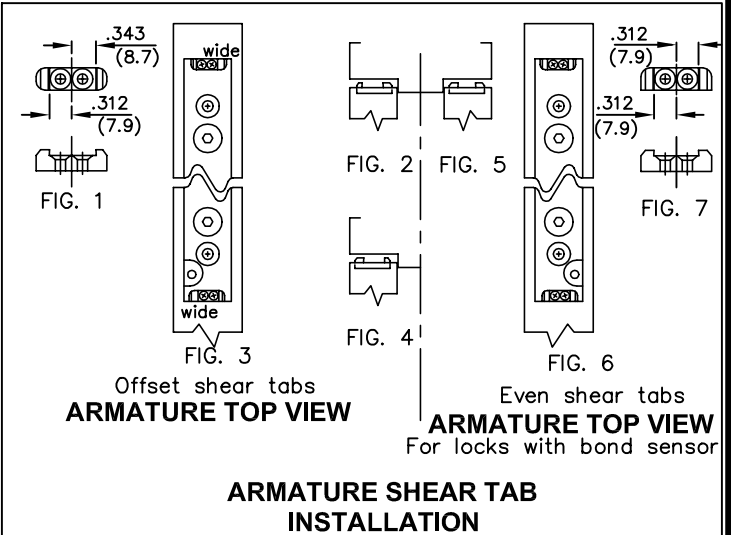

FIGURE 8



Please note drawing FIG. 1. shows two different alignments off center of the shear tab. For normal single acting door alignment see FIG. 2. For double acting doors see FIG. 6. For slightly warped single acting doors see FIG. 4. This also works well for quick release, when switch bars are used. The offset shear tab cannot be used on shear locks with bond sensors. FIG. 5 & 7.