

Saffire™ EVO LZ-D

Wi-Fi Deadbolt Lock



Applications

- Get real-time notifications, including events and access anomalies
- Manage access rights to allow or revoke access for residents and visitors in real time, from anywhere
- Easily send digital keys or PIN codes to residents and visitors from a mobile device
- Allow residents to use their mobile device, RFID credentials or PIN to access their residence or common areas
- Provide convenient one-time or recurring access PINs to service and maintenance personnel
- Control when and where residents and visitors can go throughout the building
- Quickly delete lost access media to keep the building secure.

Overview

Saffire EVO LZ-D is a cloud-connected RFID deadbolt lock that combines high-performance with aesthetics, seamlessly integrating with building technology providers and amenities for multihousing properties. The Saffire EVO LZ-D provides an easy-to-use, secure and flexible solution with the benefits of real-time connectivity. It includes the convenience of using either mobile devices, RFID credentials, or secure PINs for access to resident units, common areas and perimeter doors.

Security with IoT connectivity

The Saffire EVO LZ-D deadbolt lock is equipped with Wi-Fi onboard, ensuring

connectivity to the dormakaba Lyazon cloud and seamless integration to our Lyazon partner platforms for real-time events and user notifications. Online connectivity of the Saffire EVO LZ-D also provides continuous updates for built-in device security.

Designed for our aggregator partners

The Saffire EVO LZ product portfolio is specifically designed to integrate with our dormakaba Lyazon partner platforms to ensure a premium user experience for multifamily residents. The dormakaba Saffire EVO LZ cloud-connected smart locks allow easy access management of residences, amenities, common areas and

perimeters, all through a single integrated platform.

Security features

- Online connectivity ensures continuous firmware updates for increased device security
- BHMA A156.36 Grade 2
- UL 10C 3-hour fire rating
- Non-volatile memory maintains lock programming and audit records
- Tamper-proof design
- No need to visit the lock to update access

Factsheet

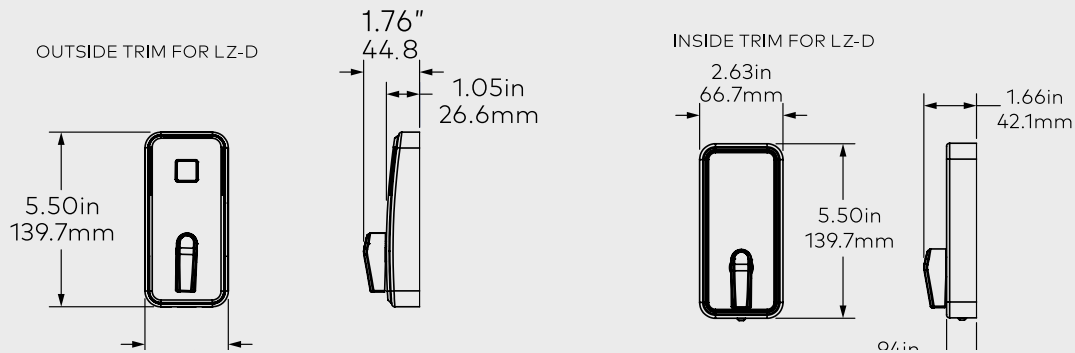

Mechanical Features

Description	Electronic deadbolt lockset with clutch mechanism and built-in Wi-Fi connectivity, RFID, Bluetooth and keypad
Handing	Field handed
Finishes**	Trim finishes: satin chrome C (626), oil-rubbed bronze Z (613), bright chrome R (625), satin nickel N (619), satin brass (606) and black K (622).
Door Thickness	From 1 3/8" to 2 1/8" (35mm to 54mm)
Locking Options	ANSI/BHMA A156.36 Grade 2 with 1" deadbolt
Batteries	3 AA for 13 months. Low-battery indicator to help with preventative maintenance. It is visible on the device and has an event notification in the system. Passive warning and notification.
Electronic Battery Backup	Electronic Lock Power Supply (ELPS) battery backup. ELPS part number 118-515990
Wi-Fi Online Control	Wi-Fi 2.4GHz IEEE, 802.11 b/g/n, WPA2, WPA, AES 128 and TLS 1.2, -70dB signal strength at the lock

** dormakaba utilizes PDV (physical vapor deposition) finishes in some instances

Mobile Access

BLE Enabled	Bluetooth Low Energy 2.4 GHz version 4.2, iOS or Android mobile device support, AES 128 and DTLS security, supported through partner mobile app
--------------------	---

Lock Operation

No Touring	New credentials applied to lock through Wi-Fi
Electronic Access	User-defined, customizable access for residents, visitors, and property managers available through partner application
Audit Trail	Audit trail managed through Wi-Fi 5,000 events
Credential Formats	dormakaba ComID high-security credentials 13.56MHz MIFARE DESFire EV2/EV3 ISO card or fob / mobile access credentials (BLE) / 6-digit PIN codes
Feedback LED	Light indicators
Diagnostics Backup	Lock diagnostics done through partner application
Memory	Non-volatile memory stores up to 5,000 events

Certifications & Testing

Certification	BHMA A156.25; BHMA 156.36 Grade 2; Florida Building Code HVHZ & non-HVHZ
Accessibility Standard	Complies with 2010 ADA Standards for Accessible Design. Must be installed according to ADA and local requirements
Fire Rating	Meets UL 10C and ULC S-104, on fire door rated up to and including 3 hours
Electronics	Compliant with RED Directive 2014/53/EU for electromagnetic compatibility and FCC part 15 and RSS-247 Industry Canada requirement
Environmental Operating Conditions	-31°F to 158°F (-35°C to 70°C), 0% to 90% non-condensing humidity at 86°F (30°C) meets IP54

Warranty

Standard Warranty	Two years
--------------------------	-----------

Any questions? We would be happy to advise you.

Contact us at: 1 800 849 8324