

**Montageanleitung
DORMA PT 30
Oberlichtbeschlag**

**Installation instruction
DORMA PT 30
Overpanel patch fitting**

Wichtige Informationen:
Important information:

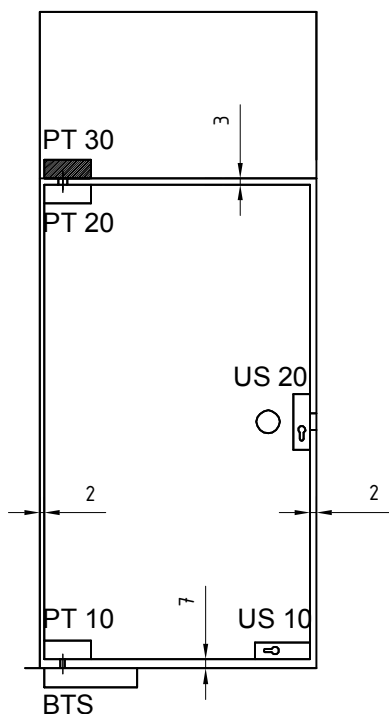

① = Bauteil/Baugruppe
 Component

1. ; 1.1 ; ... = Montagefolge
 Mounting sequence

Vor der Montage Glasflächen
 mit handelsüblichem Glasreiniger
 im Bereich der Klemmflächen reinigen.

All glass clamping areas are to
 be cleaned with standard glass
 cleaning products prior to installation.



keine Verdünnung verwenden
 Do not use thinner

Glasbearbeitung:
Glass preparation:

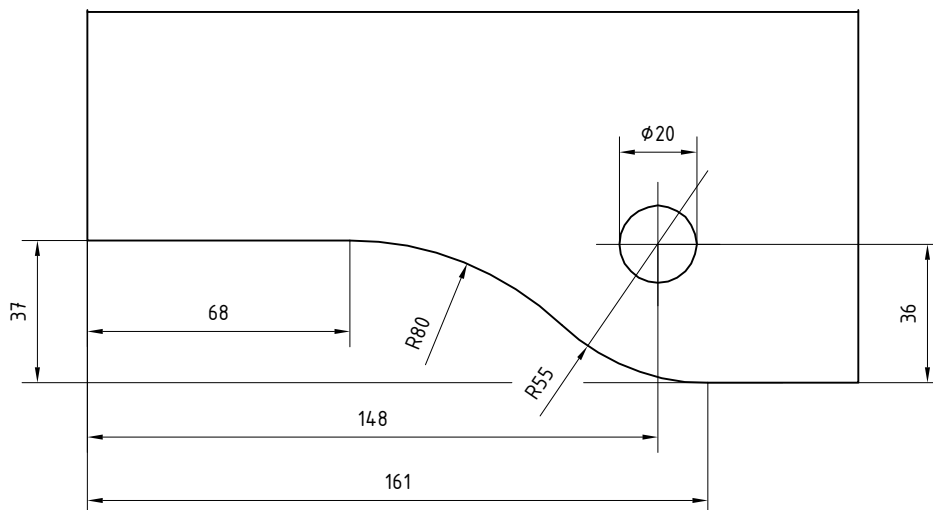

Montagewerkzeug:
Mounting tool:

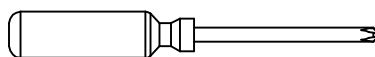
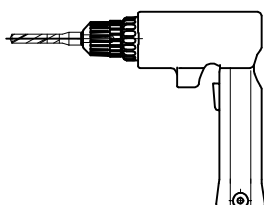

⬡ 3 mm

⬡ 5 mm

Lieferumfang:
Scope of delivery:

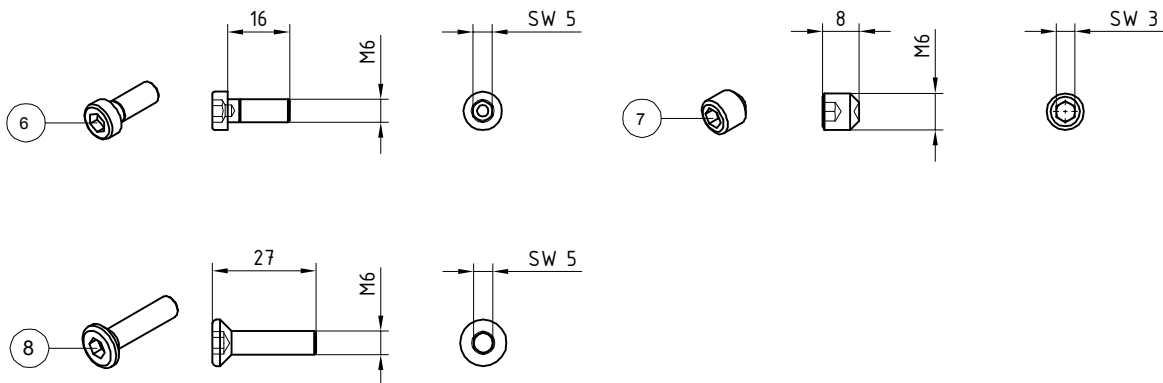
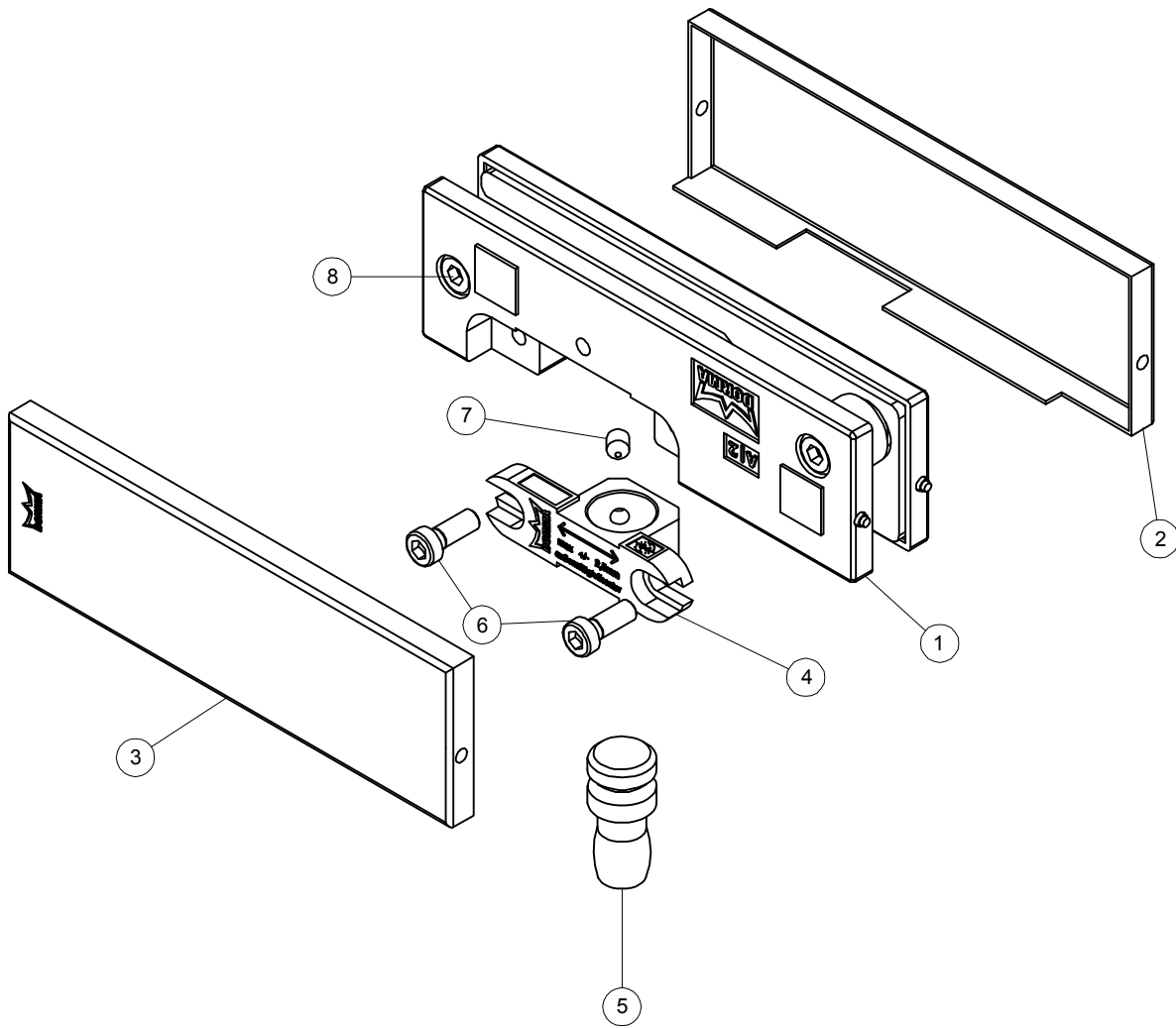

**Wandanschlussmöglichkeiten:
Wall connecting options:**

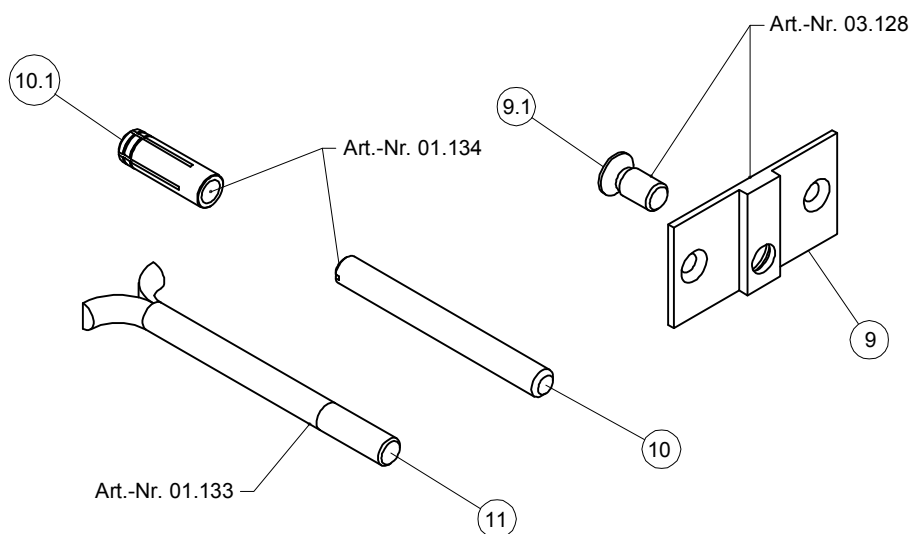

- Maueranker (11), Gewindestift mit Dübel (10), (10.1) und Befestigungslasche (9), (9.1) sind nicht im Lieferumfang enthalten!
- Wall anchor (11), threaded pin with wall plug (10), (10.1) and fixing plate (9), (9.1) are not included in delivery.

**1. Vorbereitung des Grundkörper:
1. Preparing the base unit:**

- 1.3 Folienstreifen (1.5) abziehen und Zwischenlage (1.4) aufkleben.
1.3 Pull off the backing tape (1.5) and stick on the gasket (1.4) into right place.

- 1.2 Holz-/ Kunststoffklötze entsorgen
1.2 Dispose the spacer

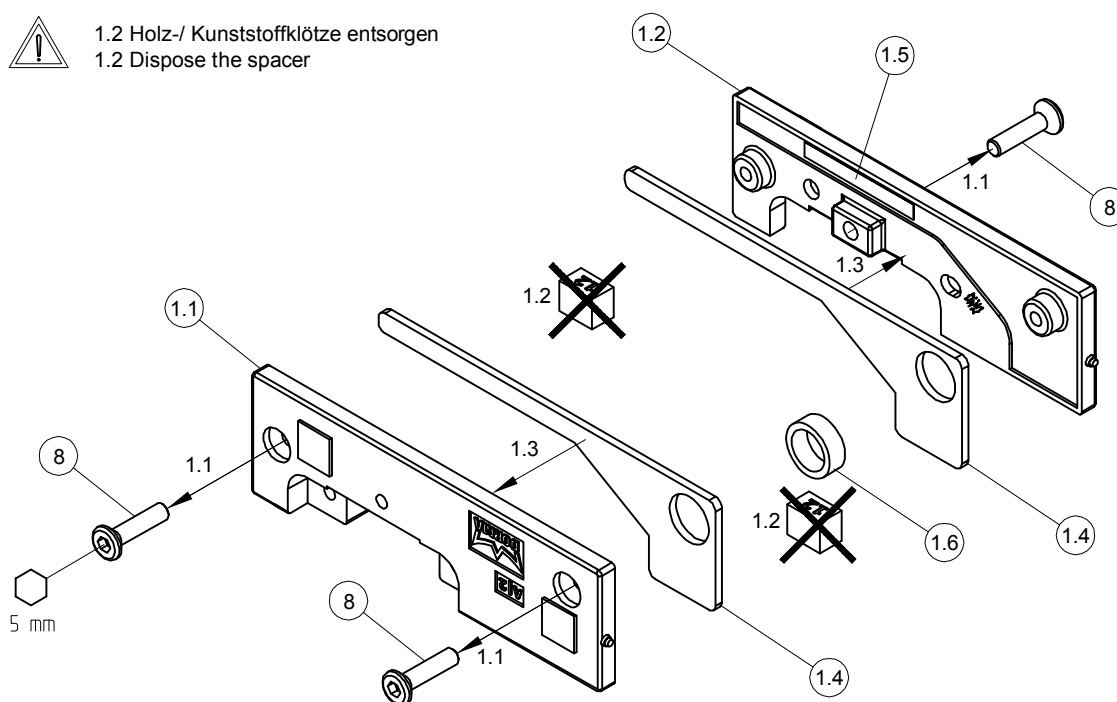

2. Montage des Grundkörpers:
2. Installation of the base unit:

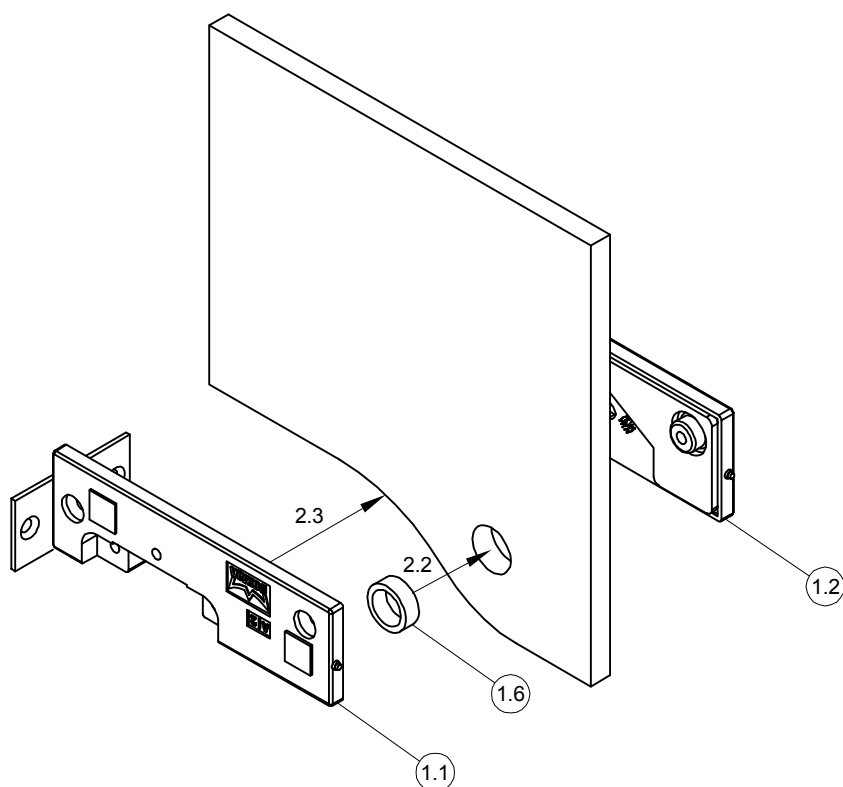
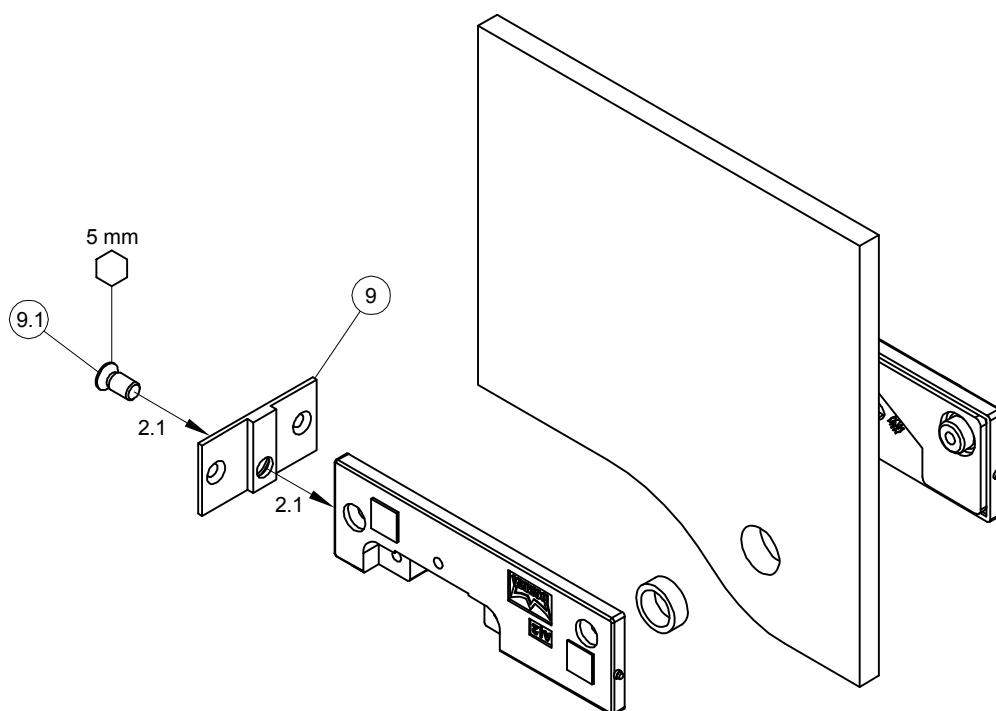

2. Montage des Grundkörpers:
2. Installation of the base unit:

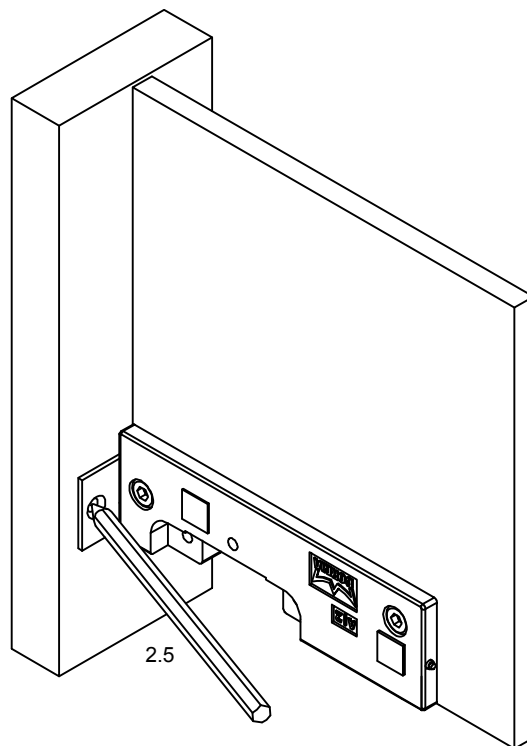
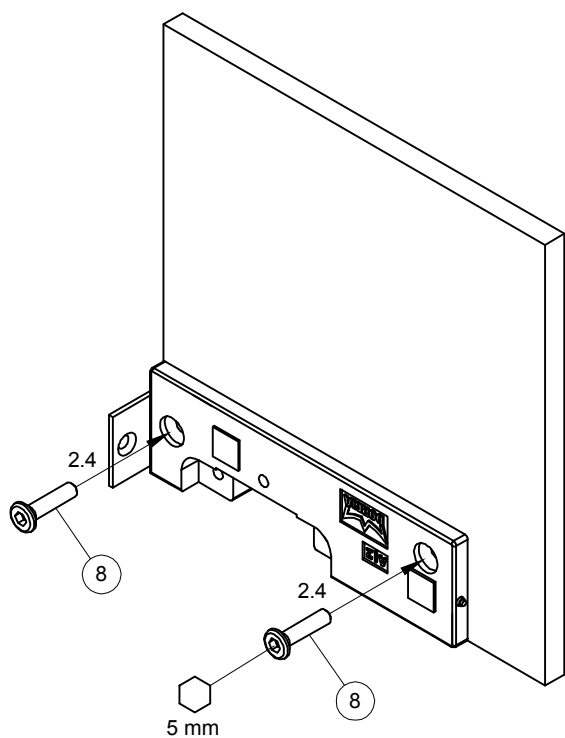

2.5 Makieren der Bohrungen
 2.5 Marking the holes

2.6 Löcher bohren
 2.6 Drill the holes

Bohrungsdurchmesser
 ist abhängig vom Dübel

Diameter of holes is
 addicted to wall plugs.

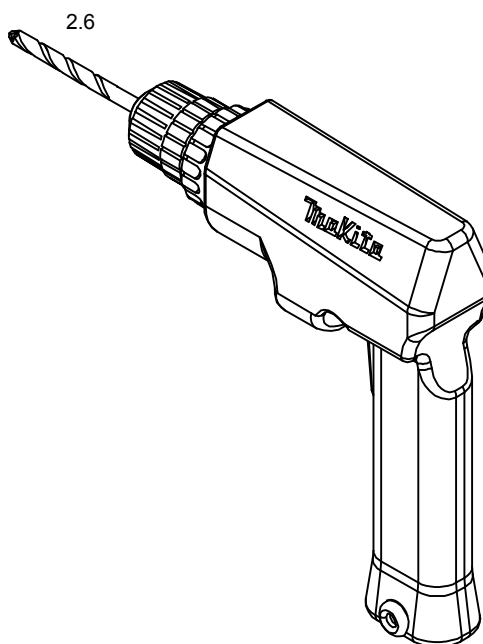

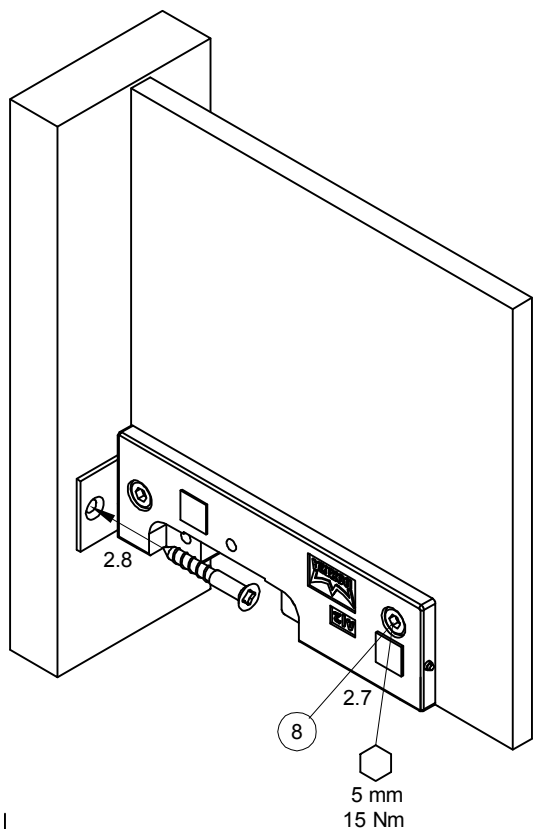

Schrauben und Dübel sind nicht im Lieferumfang enthalten!

Screws and wall plugs are not included in delivery.

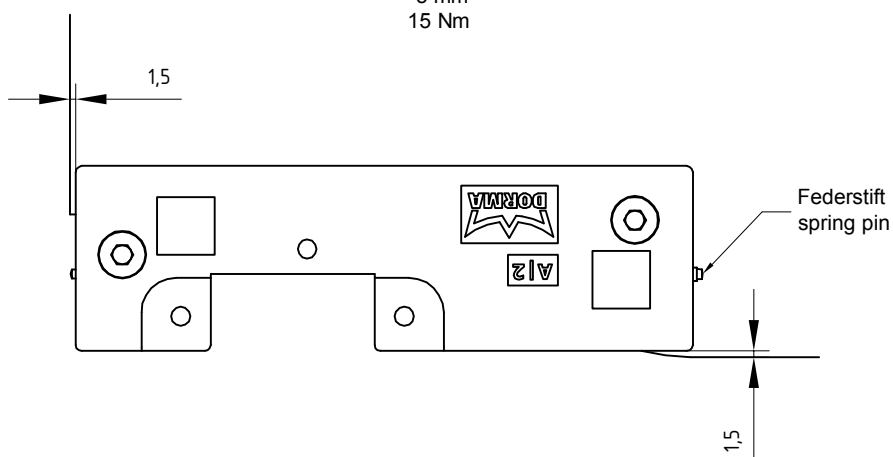

3. Montage Einsatz:
3. Mounting the insert:

3.1 Bestimmung des Drehpunktes, mit Hilfe des Einsatzes:
3.1 Determination of pivot point by means of insert:

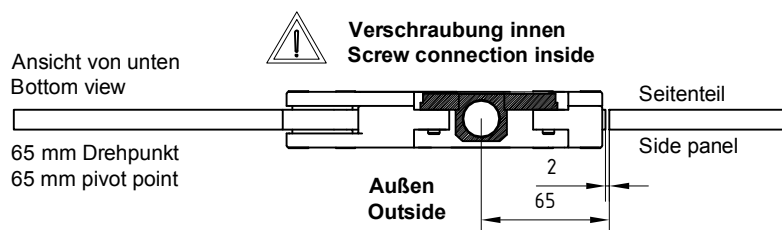
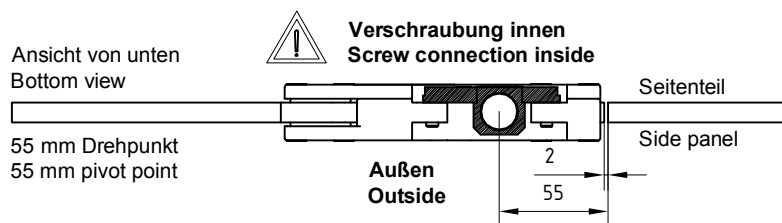

3. Montage Einsatz:
3. Installation of the insert:

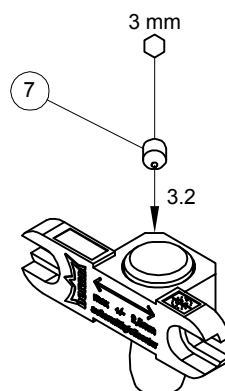
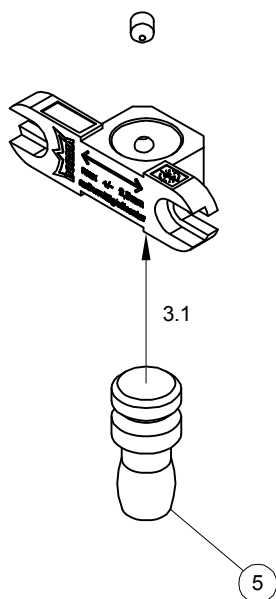

3.3 Der Einsatz muss mit etwas Kraft auf den Zapfen gedrückt werden, um die Wulst in der Buchse (PT 20) zu überbrücken. Diese dient zur Absturz-sicherung des Beschlages bei evtl. Glasbruch.

3.3 To overcome the rim in the bushing (PT 20), the insert should be pressed slightly with small force. This creates antifall guard protection if glass should break.

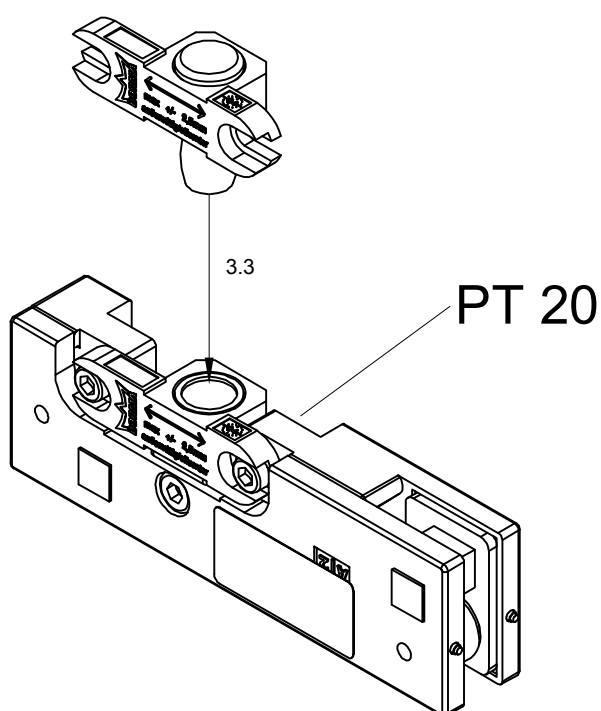

3. Montage Einsatz:
3. Installation of the insert:

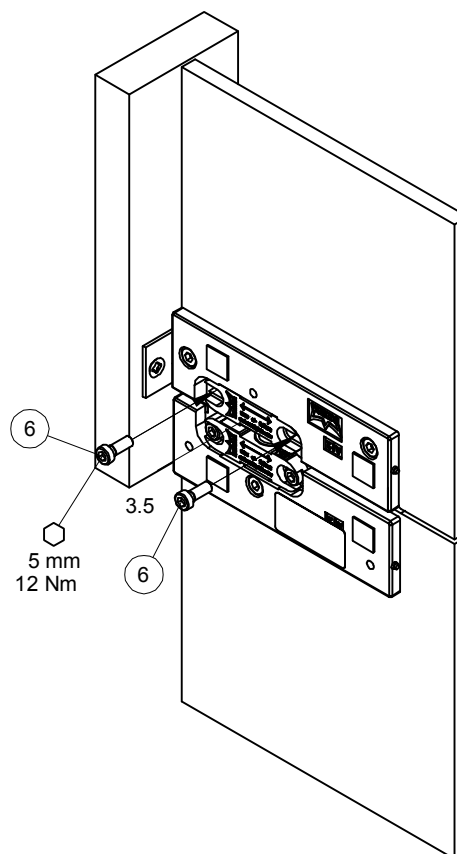
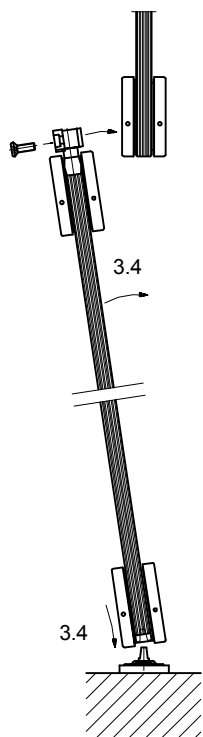

4. Montage Kappen:
4. Installation of the cover caps:

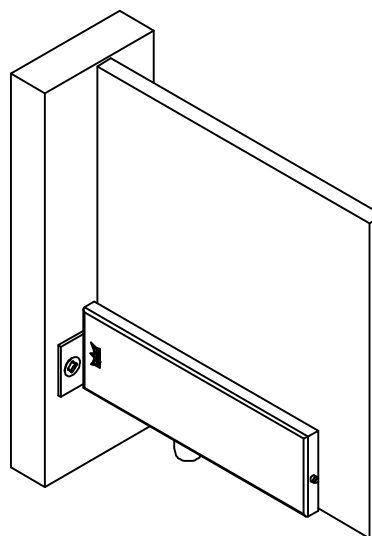
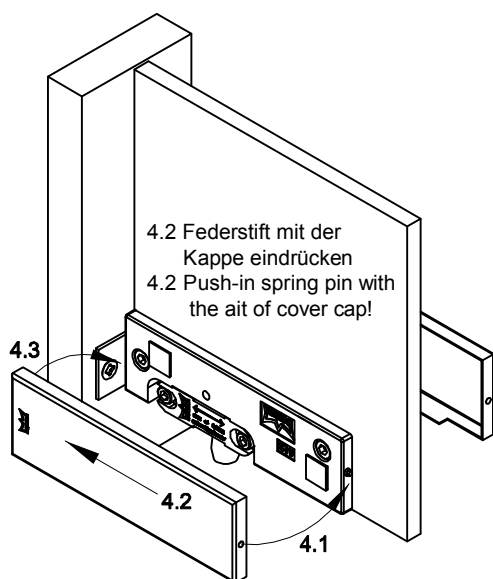

Pflege allgemein:

Die Oberflächen der Beschläge sind nicht wartungsfrei und sollten gemäß ihrer Ausführung gereinigt werden.

- Für metallische Oberflächen (Eloxaltöne, Edelstahl) bitte nur geeignete Reiniger ohne Scheuermittelanteil verwenden.
- Für lackierte Oberflächen bitte nur entsprechende lösemittelfreie Reiniger verwenden.
- Messing Oberflächen (ohne Oberflächenschutz) müssen von Zeit zu Zeit mit geeignetem Pflegemittel behandelt werden, um Anlaufen zu vermeiden.

Wartung allgemein:

Wir empfehlen die Funktion der Beschläge alle 500.000 Bewegungen durch Fachleute zu prüfen.

General care instructions:

The surface finishes of the fittings are not maintenance-free and should be cleaned according to their material and design.

- For metallic surfaces (anodised finishes, stainless steel) please use appropriate cleaning agents without abrasive additives only.
- For varnished surfaces please use appropriate solvent-free cleaning agents only.
- Brass surfaces (without surface protection) have to be treated with an appropriate maintenance agent on occasion, to avoid tarnishing.

Service and maintenance:

We recommend to check the function of the fitting all 500.000 movements by specialists.