



KTV 3/KTV 4 automatic revolving doors

Intelligent system
solutions
for individual
requirements

Our Sustainability Commitment

dormakaba is committed to foster a sustainable development along our entire value chain.

In order to give quantified disclosures of a product's environmental impact and its ecological footprint, dormakaba provides Environmental Product Declarations (EPDs). Please download the EPD and read more about our sustainability commitment here or use the QR code provided.



Contents

Introduction	05
KTV revolving doors: Perfect design and function	06
Configuration options	
System dimensions	08
Turnstile versions	09
Locks and anti-intruder protection	10
Door wings, drum walls and night shield	11
Upper and lower ceiling assembly	12
Surfaces, coatings and floor coverings	13
Direct drive, function module, operating modes	14
Planning	
Throughflow capacity in theory and practice	16
Detailed dimensions	18
Floor ring and building ground connection	20
Façades and building connections	22
Safety equipment and functional elements	24
Air curtain system	26
Electrical connection	28
KTV equipment and combinations at a glance	30

Note on product illustrations in the brochure

The product illustrations in the brochure are exemplary representations showing the current state of development. Depending on the version, the illustrations may differ from the actual products.



First impressions count. A building is entered for the first time via the main entrance. That is why its visual appearance, feel and ease of use are essential components. Undisturbed traffic flow, an improved indoor climate, noise attenuation as well as high levels of security and reliability are crucial functional requirements. KTV revolving doors perfectly combine design and function with the designated architecture. Designed according to your requirements and manufactured for sophisticated entrance areas.



KTV revolving doors

The perfect combination of design and function



KTV revolving doors from dormakaba are characterised by their shallow ceiling assembly – only 100 mm – with an integrated LED light ring. Despite the small dimensions, it is possible to combine the doors with a concealed electro-mechanical locking device and additional night shield. The low-wear KT FLEX Direct drive unit is capable of handling high visitor frequencies and is at once durable and economical. Each system is planned and manufactured according to individual customer specifications and offers multifarious equipment options.

Advantages at a glance:

- Harmonious design with concealed operating elements, sensors and LED light ring
- Fits perfectly into predetermined architecture, especially mullion-transom façades
- Easy access to all drive components despite shallow 100-mm ceiling structure
- Low-wear, low-maintenance and low-noise direct drive
- Individually adjustable size, operating mode and function
- For customised integrated door systems from a single source; can be combined with many other dormakaba products, including the door automation, preventive fire protection, escape route solutions or access control ranges



100 mm. Unique and elegant. Cost-effective and versatile.

Direct drive in shallow ceiling assembly

The electro-magnetic KT FLEX Direct drive unit is low-noise, wear-resistant and low-maintenance. The brushless, gearless drive block allows for a ceiling assembly with a minimal height of only 100 mm. The shallow design thus fits elegantly into the architecture. The operating mode determines the turnstile drive – manual, power assisted or fully automatic – as well as the rotation speed.

Improved building climate control

After usage, the revolving doors rotate the door wing to the rest position. A double row of sealing brushes on the door wings improves the building climate even at high wind loads. Thanks to the individually adjustable façade closures, the system blends harmoniously into predetermined building structures.

Anti-intruder protection to class RC2

Locking the turnstile prevents unauthorised access. The optional night shield also increases anti-intruder protection. It is formed of one or two sliding panels which seal the outer entrance to the system. A version up to resistance class RC2 in accordance with EN 1627 is available.



Illustrations show an example of a 4-wing KTV 4 revolving door with a fine-framed turnstile and an external night shield.

- 01 Ceiling assembly cross section
- 02 Direct drive and LED light ring
- 03 Door system with closed, external night shield



Individual planning service

Each door system represents an individual and integral part of the architecture. In view of diverse challenges, we offer you flexible options for KTV revolving doors that will solve even the most demanding tasks.



Quick and easy installation

Prefabricated components mean the KTV revolving door can be installed quickly, easily and smoothly. Further, no welding needs to be performed on the floor ring. Ideal for specific processes in new buildings and for refurbishment projects.

Variety of KTV combinations

System dimensions and versions at a glance



The illustration shows an example outer view of a 3-wing KTV 3 revolving door with circumferentially framed wings.

Variable dimensions for greater flexibility

The possible dimensions of a KTV revolving door depend on the number and design of the door wings as well as the selected surface finish. Detailed information regarding the design can be found in the planning section of this brochure.

System dimensions

O1 Internal diameter	W = 2,000 to max. 3,800 mm
O2 Clear passage height	LH = 2,100 to max. 4,000 mm
O3 Canopy height	CH ≥ 100 to max. 1,000 mm

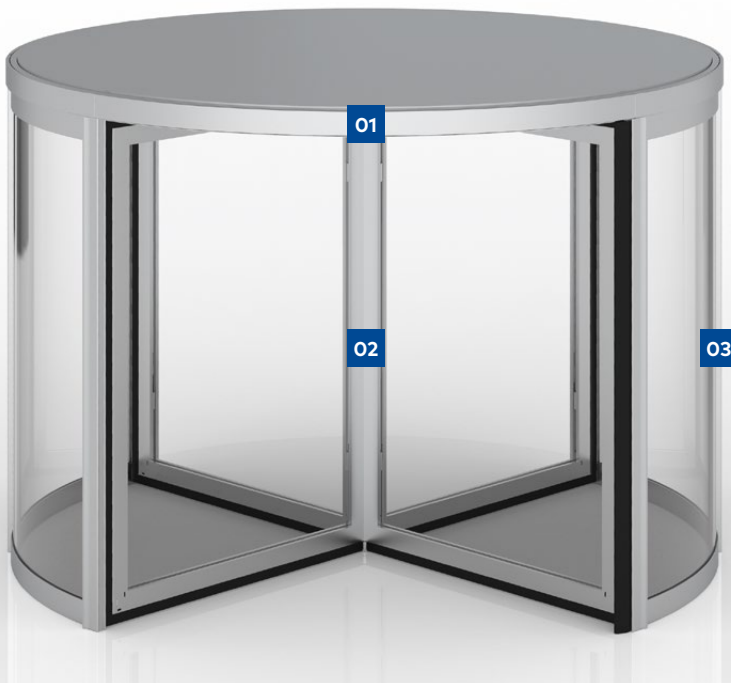

4-wing revolving door KTV 4

- 01** 100 mm canopy height
- 02** Circumferentially framed door wings
- 03** Drum wall

Turnstile versions

3- or 4-wing turnstile

The KTV turnstile can be equipped with three or four door wings. The advantage of the 3-wing door is that it provides more space in the individual segments. The lower weight also reduces the effort needed to enter manual and power-assisted doors. In addition, with 3-wing doors, higher clear passage heights are practicable, which makes particularly streamlined door designs possible. 4-wing doors offer wider entrance and exit areas to facilitate simultaneous entering and exiting of the building. With a higher number of seals toward the posts, such doors also provide better protection against draughts, noise and external climatic influences when in rest position.

Transport opening

This function serves as a clear passage for bulky objects in order to temporarily increase the throughflow capacity and for continuous ventilation in corresponding weather conditions. A tool can be used to loosen and collapse one or – in the case of KTV 4 – two door wings of the turnstile.

Bookfold/escape route opening

If a defined force is exceeded, the door wings become collapsible in both directions. This means the building can be exited rapidly through both sides of the door, regardless of the rotation direction. Depending on the country and local regulations, a system equipped with collapsible wings may also be suitable for use in escape routes and emergency exits.

Fine-framed turnstile

To achieve a particularly transparent appearance, a fine-framed, rigid door wing may be used. Reinforced 12-mm toughened safety glass (TSG) makes it possible to dispense with disruptive profiles in the central door axis. The door is locked via a manual floor locking device.

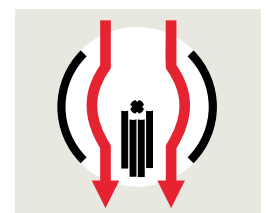
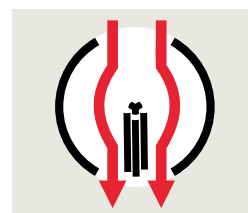
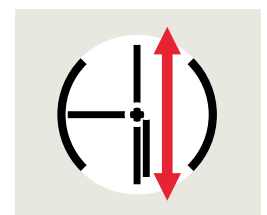
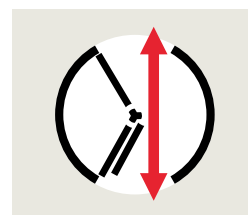
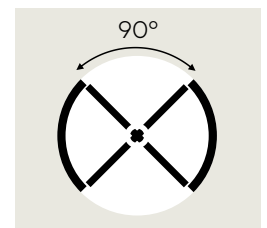
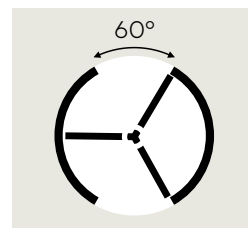

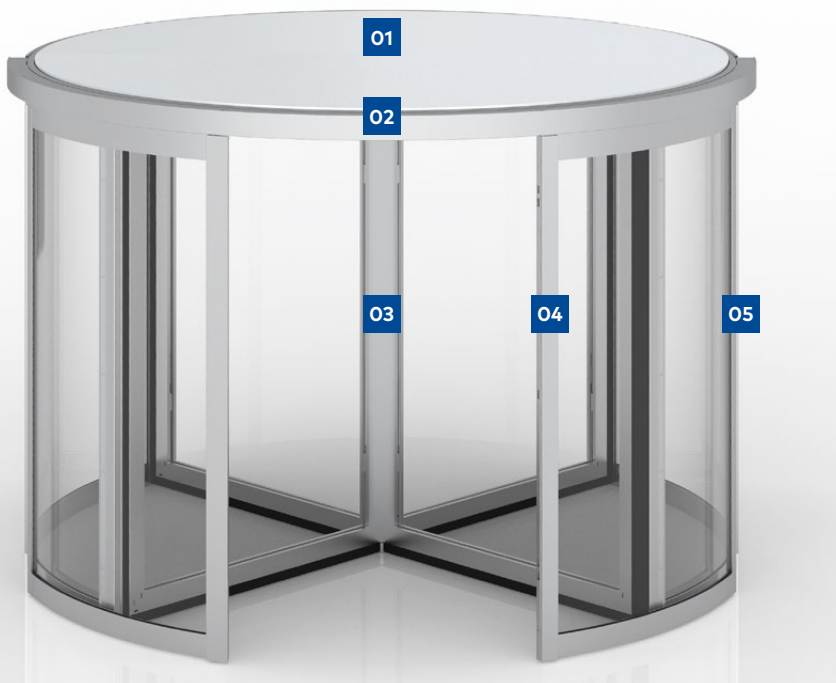

4-wing door system KTV 4

- 01 White melamine dust cover
- 02 100 mm canopy height
- 03 Circumferentially framed door wing
- 04 External night shield in semi-closed position
- 05 Drum wall

Locking devices and night-shields

Manual locking

The turnstile is latched against unauthorised entry by a rod lock system concealed in the door wing. With a fine-framed turnstile, a floor locking device is used.

Electro-mechanical locking

After changing the program switch, the door wings are automatically positioned and closed: an electro-mechanical locking device installed in the ceiling assembly engages a solid tab on the upper edge of the door wing and locks the turnstile. The door may be released for individual entry using the night/bank function. Sensors or push buttons prevent unintentionally trapping of someone.

Manual or automatic night shield

A night shield is ideal for keeping out uninvited guests, leaves or clogging. Once the revolving door has been powered off, operation and locking are performed manually or automatically via an electro-mechanical night shield. Doors with a night shield can be equipped with suitable components, e.g. special types of glass and locking devices, to comply with resistance class RC2 in accordance with EN 1627.

Internal night shield

- Door system can be offset off-centre to the façade axis
- Manual night shield (canopy height CH min. 200 mm) and automatic night shield (canopy height CH min. 300 mm)

External night shield

- Manual night shield (canopy height CH min. 100 mm)
- Anti-intruder protection to resistance class RC2
- Control elements must be installed in proximity to the passage area

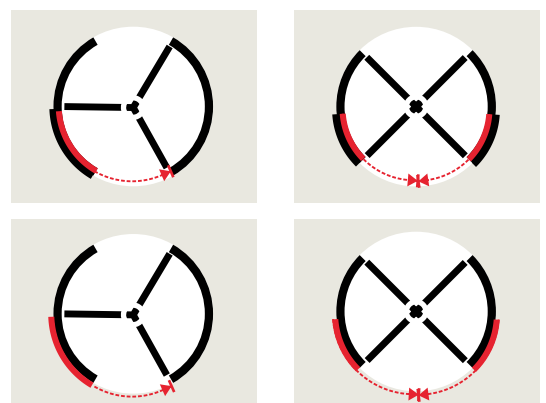
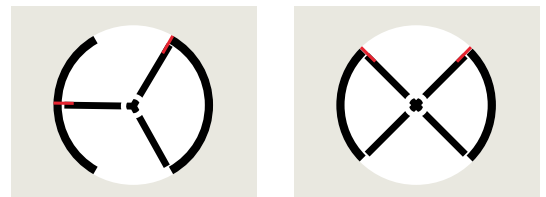

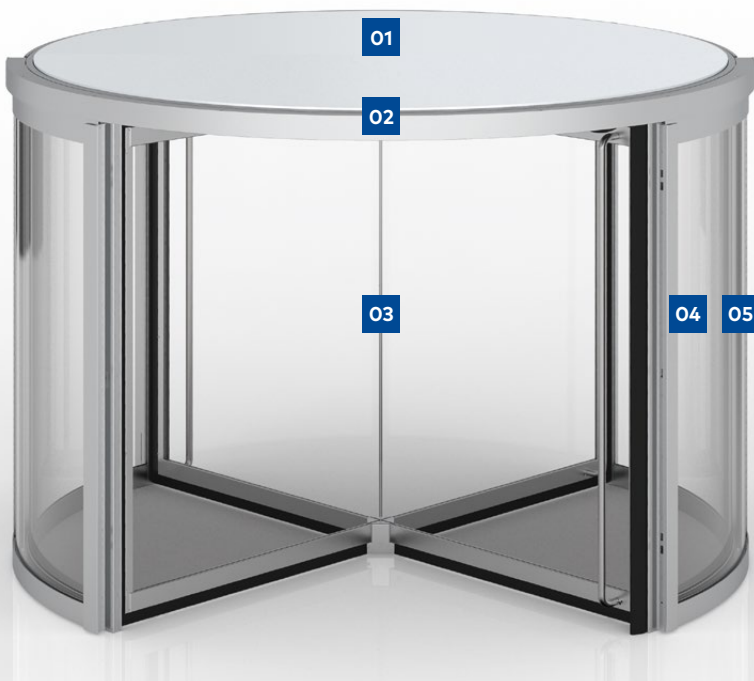

4-wing door system KTV 4

- 01** White melamine dust cover
- 02** 100 mm canopy height
- 03** Fine-framed door wings without centre column with vertical bar handles
- 04** External night shield in open position
- 05** Drum wall

Door wings, drum walls and night shields

Configure all elements of a KTV door system according to your individual and technical requirements.

Door wing

The 3- and 4-wing versions are equipped as standard with 6-mm toughened safety glass (TSG). The profiles of the circumferentially framed door wings use the "Twin-Brush" double brush system, which means the transitions to the drum wall, upper ceiling and floor are significantly better sealed than with simple brush sealing systems.

Optional extras:

- Collapsible wing (transport or bookfold/escape route opening)
- Glazing with toughened safety glass (TSG) or laminated safety glass with different glass thicknesses
- Burglary-resistant glazing in accordance with class P4A, insulating glass or low-iron clear glass (extra clear)
- Additional mid-rails as fender or decorative design element
- Manual or automatic locking
- Short handles or vertical or horizontal cross bars for manual and power-assisted revolving doors

Drum walls and night shield

The drum walls and night shield wings are manufactured from aluminium profiles and are equipped as standard with 8.76 mm thick panes of laminated safety glass.

Optional extras:

- Burglary-resistant glazing in accordance with class P4A, insulating glass or low-iron clear glass (extra clear)
- Additional mid-rails as fender or decorative design element
- Opaque panel infill in system-coordinated finish, 18 mm thick, aluminium sheet with internal, insulating styrodur core.

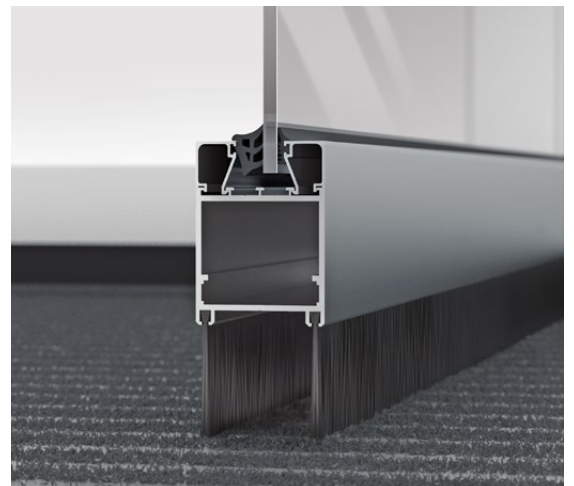

Catchword escape route

In some countries, revolving doors with collapsible door wings (bookfold) are suitable for use in escape routes and emergency exits under certain conditions. In other countries, this may be ruled out categorically. The usability of the system must be clarified with and approved by the relevant authorities prior to operation.



Catchword night/bank function

The locked door can be released via an electronic access system, e.g. a card reader, to allow access to the building. Typical scenarios are night access to hotels or the self-service area of banks.



View from inside: 4-wing KTV 4 door system

- 01** Upper ceiling with optional air curtain
- 02** Optional raised canopy height 500 mm
- 03** Circumferentially framed door wings



View from outside: 4-wing KTV 4 door system

- 04** Upper ceiling with rain-proof metal sheet on top
- 05** Fine-framed door wings

Upper and lower ceiling structure

The 100 mm canopy available with all drive types means an underfloor drive unit that is vulnerable to malfunction is no longer required. All types of turnstiles, electro-mechanical locking of the door wings, an external manual night shield with burglary-resistance class RC2 as well as other options can therefore be implemented.

If desired, the system is also available with a canopy up to a height of 1,000 mm. If the canopy is raised, it is possible to raise the upper ceiling of the system to the same height so that the door closes flush with the top edge.

Upper ceiling

The standard model has a dust cover with sturdy, white melamine-coated multi-layer plates.

Optional extras:

- Decorative sheet metal in system-coordinated finish
- Rain-proof metal sheet cover
- Preparation for on-site sealing with foil or bituminous sheeting
- Canopy height up to 1,000 mm

Lower ceiling

The standard model consists of multi-layer plates with white melamine coating, which are divided into eight even segments. Internal system components thus require minimal maintenance effort.

Option:

- Lower ceiling segments made of sheet-metal elements in system-coordinated finish

LED light ring for steady illumination

The round LED light ring means all systems equipped with the KT FLEX Direct drive system (KTV M with speed limiter, KTV P, KTV S and KTV A) have a modern lighting system. Unlike with conventional LED spotlights, which are temporarily concealed depending on the position of the door wings, permanent overall illumination of the entire system is possible. The dirty edges that inevitably form on conventional spot lights over a long period of operation do not develop. The light ring is dimmable and the light colour adjustable between warm white and cold white.





View from inside: 3-wing KTV 3 door system

- 06** Upper ceiling with decorative sheet metal on top
- 07** Circumferentially framed door wing
- 08** Optional floor mat

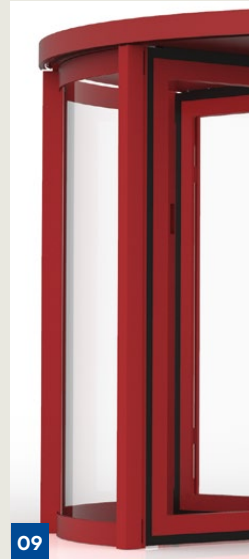

Surfaces

- 09** Surface coating in accordance with RAL
- 10** Surface aluminium anodized E6/C0 (standard)
- 11** Surface INOX stainless steel



Surfaces, coatings and floor coverings

Profile and sheet-metal lagging

The standard model of the profile and cover surfaces consists of powder coating in individually selectable RAL colour tones. Colour powders from all common powder manufacturers are available. Where appropriate, DB or NCS colours can also be powder coated.

Optional extras:

- Anodised finishes in accordance with EURAS colour grades
- Special colours according to specifications
- Stainless steel cladding in satin finish or polished surface quality (INOX)
- Increased protection due to particularly resistant coating structure, for example at locations near the coast or near a swimming pool
- Alternatively, the use of particularly corrosion-protected stainless steel plates is also possible

Floor covering

The system can be installed on existing floors, which is advantageous for retrofitting or renovation. In new construction projects, a stainless steel floor ring is usually set and casted in the screed. The sophisticated fastening system makes anchoring the component in the subfloor fast and easy – without additional welding and with precise alignment to the required height level. The casting panels supplied as standard facilitate the professional casting of the floor rings in the screed. In addition, a floor mat can be inserted into the floor ring as a cleaning zone.

Optional extras:

- Floor mat with textile or rubber insert
- Clamping flange for on-site foil sealing (at centre axis or circumferentially outside), also conforming to DIN 18195 Part 5
- Floor sheets or foil guide plates
- Stainless steel floor pan with drainage connection



- 01 3-wing KTV revolving door with control elements
- 02 P, S and A function modules
- 03 Active safety sensors integrated in the canopy (full-energy operation)
- 04 Program switch
- 05 Handicap push button
- 06 Emergency stop switch

One direct drive, three functional modules, four operating modes: from manual to servo-assisted to fully-automatic.

Except for the purely manual version without speed limiter, all KTV revolving doors are equipped with the KT FLEX Direct drive system. The operating mode is determined by the inserted P, S or A function module, which can be subsequently replaced at any time. Depending on the module, additional safety sensors and switching elements may be required.

1. Manual revolving door with speed limiter (no function module)

In moderate traffic, light and small revolving doors are easy to operate manually. The turnstile is then only accelerated and guided manually. Additional safety sensors are not required. The KT FLEX Direct drive system acts exclusively as speed limiter. The speed at which the limiter starts as well as the strength of the resistance are adjustable.

2. KTV P revolving door with automatic positioning control (function module P/low-energy)

The low-energy drive unit with automatic positioning is recommended for entrance areas with a reception or lobby, if these are not particularly large or heavily frequented. After manual usage, the drive system rotates the door wings back to the starting position, which ensures optimal positioning of the brush seals on the posts and an attractive appearance in the home position. An active safety sensor system is not required. The speed limiter is included with this drive type.

Operating modes adjustable via program switch:

- Automatic 1: Manual starting and acceleration of the turnstile; the door automatically rotates to home position (door closed) after each usage.
- Automatic 2: The door rotates continuously at check-speed; acceleration to walking speed is performed manually.
- Inactive/Summer: The door wings can be moved freely (e.g. for cleaning purposes). If the door is equipped with a bookfold turnstile or transport wings, these can be opened (e.g. as a transport opening or for continuous ventilation).
- Off: The door rotates to the home position and can be locked or, in the case of an electro-mechanical door wing lock, the door wings lock automatically. The system lighting is disabled with a time delay in this mode.

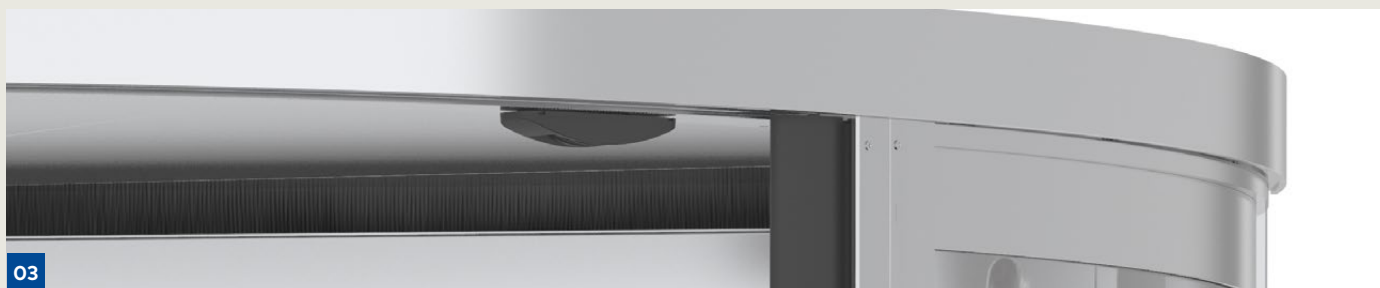

03



04



05



06

3. KTV S revolving door with servomatic (S/low-energy function module)

In addition to simple positioning of the door wings in the home position, this low-energy drive offers added convenience functions. An active safety sensor system is not required. The speed limiter is included with this drive type.

Operating modes adjustable via program switch:

- Automatic 1: Motion sensors start the rotation of the door wings at check-speed. Acceleration to walking speed is performed manually. After each usage, the door automatically returns to the home position (door closed).
- Automatic 2: The door turns continuously at check-speed; acceleration to walking speed is performed manually.
- Summer: Optional collapsible door wings can be manually folded to the side, e.g. as transport opening or for continuous ventilation.
- Off: The door rotates to the home position and can be locked or, in the case of an electro-mechanical door wing lock, the door wings automatically lock or switch to night/bank function.

4. KTV A automatic revolving door (function module A/full-energy)

For high pedestrian traffic as well as a heavy turnstile, the drive optimizes daily operation with fully-automatic convenience functions. Depending on the local requirements, additional, active safety sensors are required (see safety equipment on Page 25).

Operating modes adjustable via program switch:

- Automatic 1: Motion sensors start the rotation of the door wings at walking speed. After each usage, the door automatically returns to the home position (door closed).
- Automatic 2: The door turns continuously at check-speed; acceleration to walking speed occurs automatically when a motion sensor is triggered.
- Summer: Optional collapsible door wings can be manually folded to the side, e.g. as transport opening or for continuous ventilation.
- Off: The door rotates to the home position and can be locked or, in the case of an electro-mechanical door wing lock, the door wings automatically lock or switch to night/bank function. The rotation speed can optionally be temporarily slowed in automatic mode by a "handicap button". The duration and speed of decrease are adjustable.

System planning

Traffic capacities in theory and practice

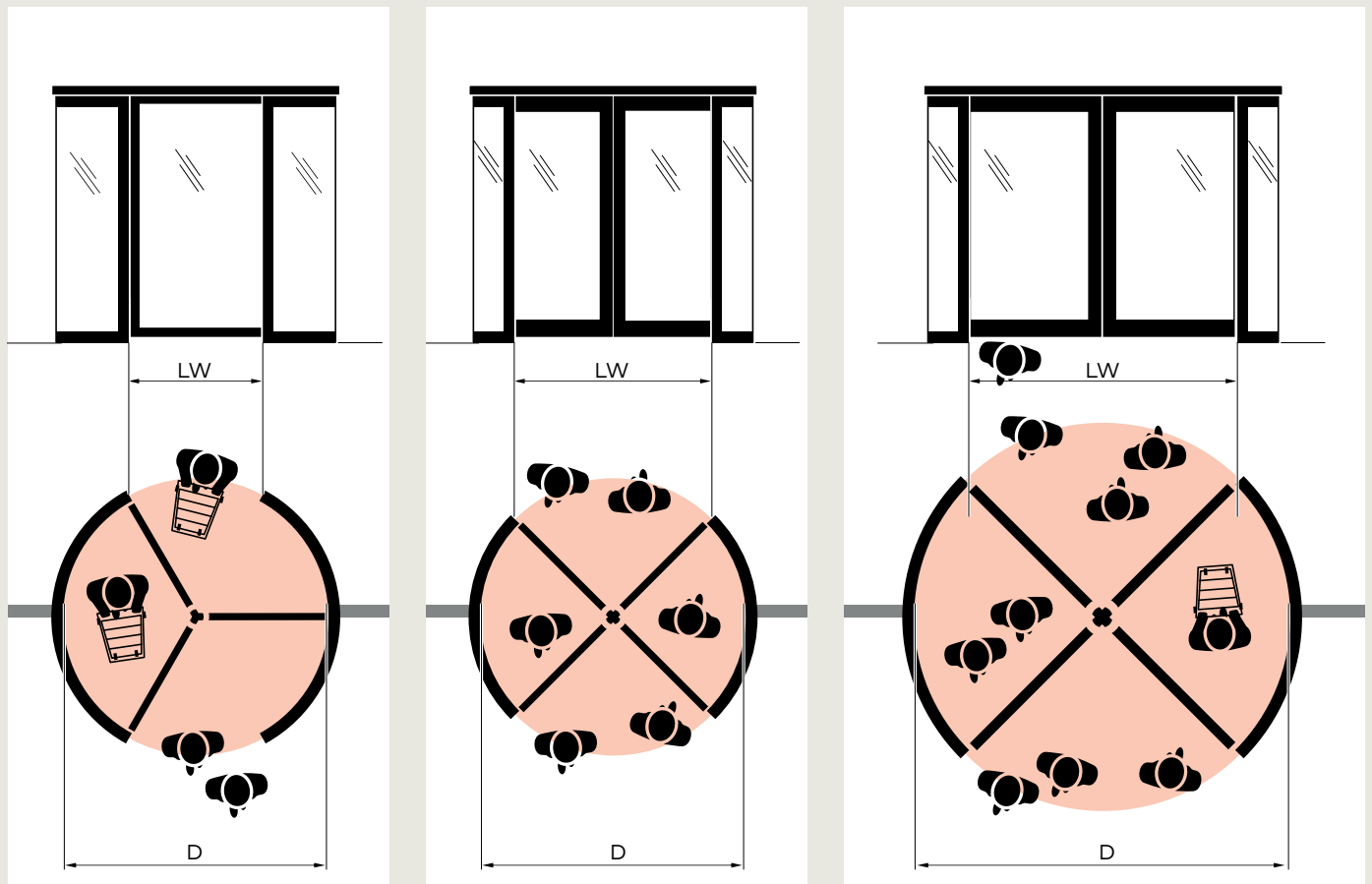

Theoretical passage capacity of an automatic revolving door

Persons per minute per direction, KTV A (full-energy)

D Ø	KTV 3 3-wing	KTV 4 4-wing
2,000	22	29
2,200	20	27
2,400	18	24
2,600	34	23
2,800	31	21
3,000	29	39
3,200	41	36
3,400	38	34
3,600	36	32
3,800	46	46

The maximum capacity indicates how many people per minute can pass through the revolving doors in one direction during a time window when the highest number of people are expected (for example: start or end of shift, lunch break), assuming that the traffic flow is constant and undisturbed at all times and that all sections are always filled with the maximum possible number of people.

The proper system dimensions and, if necessary, the number of systems to be installed in parallel may be inferred from the expected number of people. The initial question is how many people may enter or exit the building in a short period of time.

In the "passage capacity" table, an automatic revolving door (full-energy) is used as an example. The values display the theoretical maximum values under the assumption that the door is operated optimally at all times. This means that it rotates permanently at the maximum permissible speed, is not slowed down or stopped and all compartments are occupied in both directions with the maximum possible number of persons. In reality, there will be significant deviations due to various factors. Clarify your specific application in consultation with us.

1. Influencing factor: User

- How much space does an individual user need in the compartment?
- Are people with luggage, walkers, shopping carts or strollers expected?
- Is use by children, elderly, frail or mobility-impaired individuals to be calculated?
- Can or will two or more people use a compartment at the same time?

The usage profile specifies the dimensions for the compartment space and the circulating speed: a revolving door for elderly people with a walker and accompanying person is designed differently to an office building with peak usage at the start of a working day.

Barrier-free design

In accordance with German Industrial Standard DIN 18040, revolving doors are not barrier-free. Nevertheless, convenient use of automatic revolving doors is also possible for people with reduced mobility or persons in wheelchairs if the system type and diameter are designed to comply with the requirements and the door is equipped with buttons to temporarily reduce the rotation speed. For people in wheelchairs, the use of 3-wing doors with a diameter of at least 3.4 m is recommended. The system diameter must be correspondingly larger in order to accommodate an accompanying person.

2. Influencing factor: Size of the compartment space

- How large should/can the system diameter (D) be?
- Is a 3- or 4-wing turnstile preferred?

A larger diameter results in a larger compartment space. A 3-wing door with the same diameter also offers more space here. In the "passage capacity" table, it is assumed that more people will fit into the compartment if the compartment space is larger.

In practice, however, often only one person enters the compartment, which is why the maximum capacity is rarely reached. The 3-wing door is recommended if more compartment space is required for transporting luggage or bulky items. The 4-wing door is recommended for increased people flows, especially when accessed in both directions at the same time. It also provides better protection against environmental influences and wind ingress.

3. Influencing factor: Rotation or peripheralspeed

- Should the system be operated fully automatically?
- Is a purely manual or power-assisted operation desired?

The maximum possible rotation speed of the system and thus also the passage capacity depend on several factors. Normative specifications for permissible peripheral speeds and forces must be observed. This might mean that a larger door has a lower theoretical passage capacity than a slightly smaller door. Only when the compartments provide enough space for another person does the capacity increase. In manual or semi-automatic operation (low-energy with function module P or S), higher or lower capacities can be achieved depending on the setting of the speed limiter.

Automatic revolving doors are particularly convenient: the installed safeguarding devices regulate the speed and automatically slow down or stop the system if necessary. Manual acceleration of the system is not required but also not allowed.

Revolving doors with low-energy drives (KTV P and KTV S) must be manually accelerated to the required entry speed. Standard-compliant protection of the system is essentially carried out by passive safeguarding devices (impact protection strips and limitation of the drive power). In practice, this can even result in a steadier flow of people and thus a higher passage capacity than with a fully automatic system.

Detailed dimensions

KTV 3 3-wing door

The table shows the possible system dimensions. Any intermediate size is possible.

D	Inside diameter	2,000	2,200	2,400	2,600	2,800	3,000	3,200	3,400	3,600	3,800
B	Outside diameter										
	01 Without night shield	2,096	2,296	2,496	2,696	2,896	3,096	3,296	3,496	3,696	3,896
	02 External night shield	2,262	2,462	2,662	2,862	3,062	3,262	3,462	3,662	3,862	4,062
	03 Internal night shield	2,216	2,416	2,616	2,816	3,016	3,216	3,416	3,616	3,816	4,016
LW	Clear passage width	940	1,040	1,140	1,240	1,340	1,440	1,540	1,640	1,740	1,840
	(poss. escape route width)	895	995	1,095	1,195	1,295	1,395	1,495	1,595	1,695	1,795
LH	Technically possible system height depending on the door wing equipment										
	TSG 6 mm	4,000	4,000	4,000	3,800	3,400	3,200	3,000	2,900	2,700	2,600
	TSG 6 mm (INOX)	4,000	3,900	3,900	3,700	3,300	3,000	2,800	2,700	2,500	2,300
	TSG 8 mm	4,000	3,900	3,900	3,700	3,300	3,000	2,800	2,700	2,500	2,300
	Fine-framed TSG 12 mm	3,900	3,500	3,200	3,000	2,700	2,600				
	Fine-framed TSG 12 mm (INOX)	3,300	3,000	2,700	2,500	2,300	2,100				
SH	Canopy height	Freely selectable between 100 and 1,000 mm. Depending on the technical design, the minimum height varies:									
		<ul style="list-style-type: none"> • Internal night shield min. 200 mm • Automatic night shield min. 300 mm • Surface mounted air curtain min. 400 mm 									

Minimum façade opening height = clear passage height + canopy height + min. 40 mm

Minimum façade opening width = B + min. 80 mm

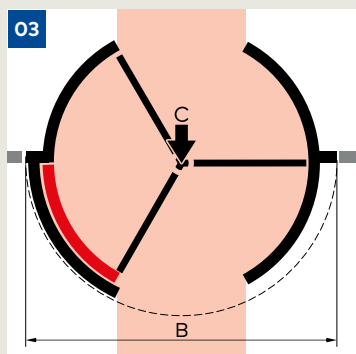
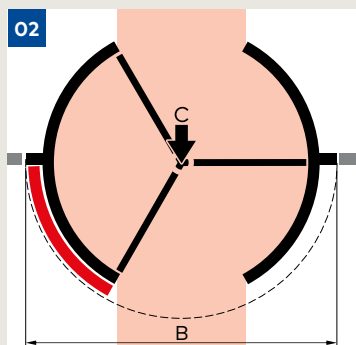
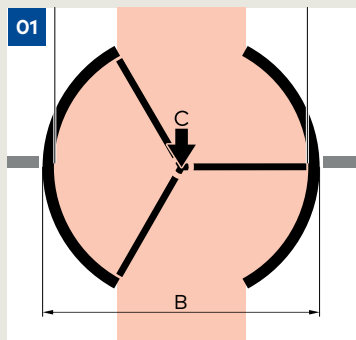
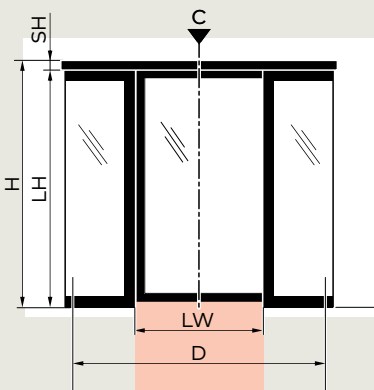

Technically possible system heights LH (clear passage height) depending on inside diameter D.

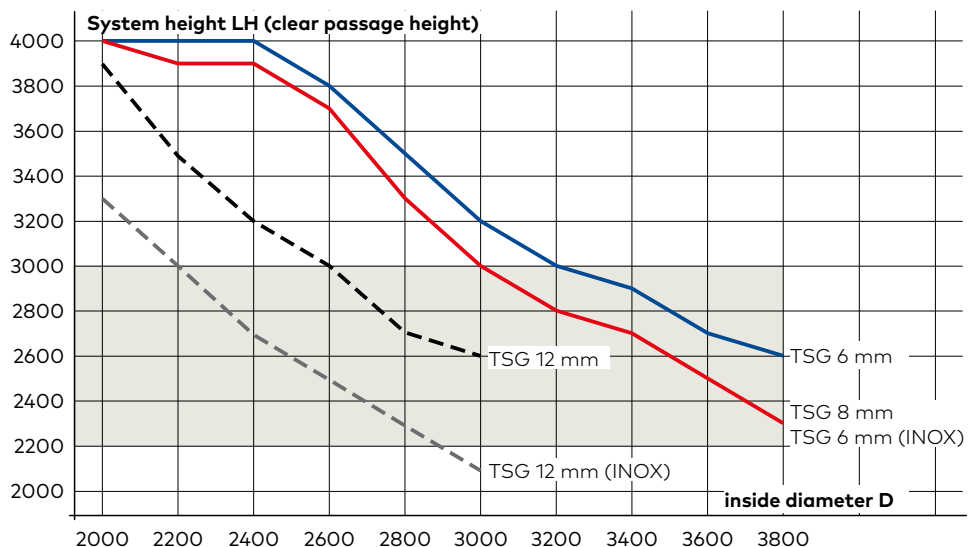

■ Possible range for systems with resistance class RC2

KTV 4 4-wing door

The table shows the possible system dimensions. Any intermediate size is possible.

D	Inside diameter	2,000	2,200	2,400	2,600	2,800	3,000	3,200	3,400	3,600	3,800
B	Outside diameter										
O1	Without night shield	2,096	2,296	2,496	2,696	2,896	3,096	3,296	3,496	3,696	3,896
O2	External night shield	2,262	2,462	2,662	2,862	3,062	3,262	3,462	3,662	3,862	4,062
O3	Internal night shield	2,216	2,416	2,616	2,816	3,016	3,216	3,416	3,616	3,816	4,016
LW	Clear passage width	1,364	1,505	1,647	1,788	1,930	2,071	2,213	2,354	2,496	2,637
	(poss. escape route width)	895	995	1,095	1,195	1,295	1,395	1,495	1,595	1,695	1,795
LH	Technically possible system height depending on the door wing equipment										
	TSG 6 mm	4,000	4,000	4,000	3,800	3,400	3,200	3,000	2,900	2,700	2,600
	TSG 6 mm (INOX)	3,600	3,400	3,100	2,900	2,800	2,600	2,500	2,300	2,200	2,100
	TSG 8 mm	3,900	3,600	3,300	3,000	2,800	2,600	2,500	2,300	2,200	2,100
	Fine-framed TSG 12 mm	3,500	3,200	2,900	2,700	2,500	2,300				
	Fine-framed TSG 12 mm (INOX)	3,300	3,000	2,700	2,500	2,300	2,100				
SH	Canopy height	Freely selectable between 100 and 1,000 mm. Depending on the technical design, the minimum height varies:									
		<ul style="list-style-type: none"> • Internal night shield min. 200 mm • Automatic night shield min. 300 mm • Surface mounted air curtain min. 400 mm 									

Minimum façade opening height = clear passage height + canopy height + min. 40 mm

Minimum façade opening width = B + min. 80 mm

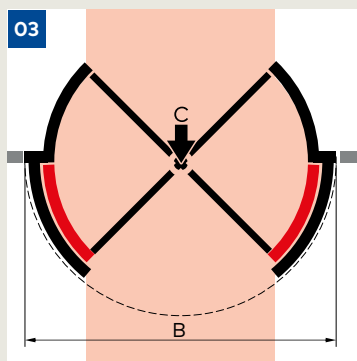
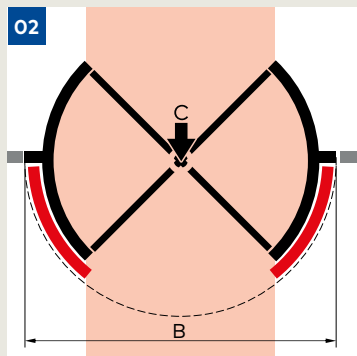
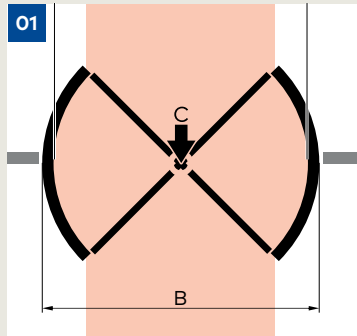
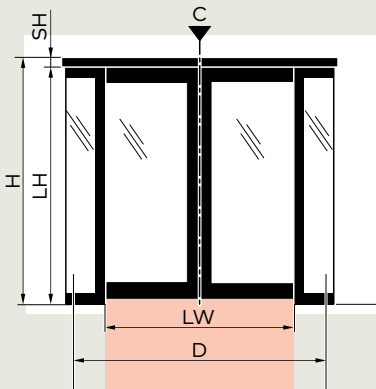

Technically possible system heights LH (clear passage height) depending on inside diameter D.

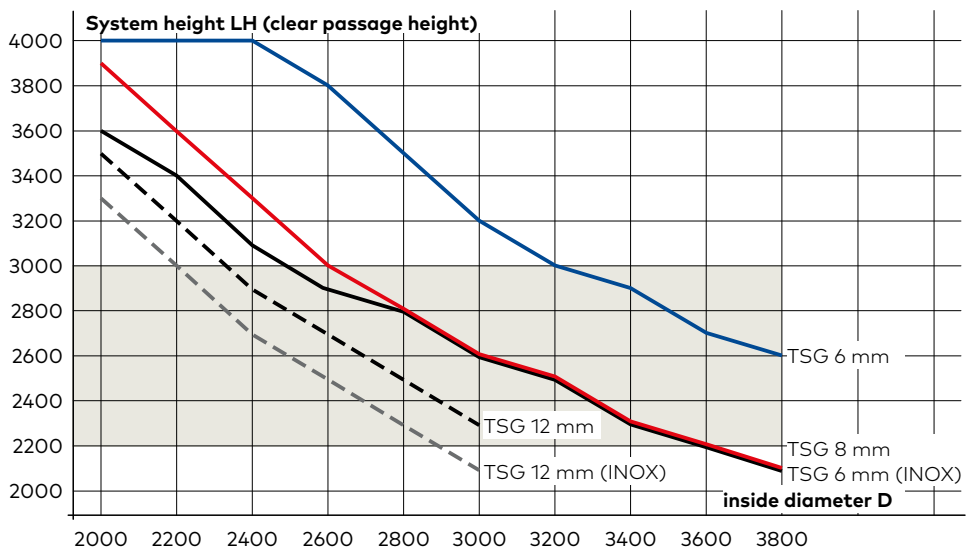

■ Possible range for systems with resistance class RC2

Floor ring and ground connection

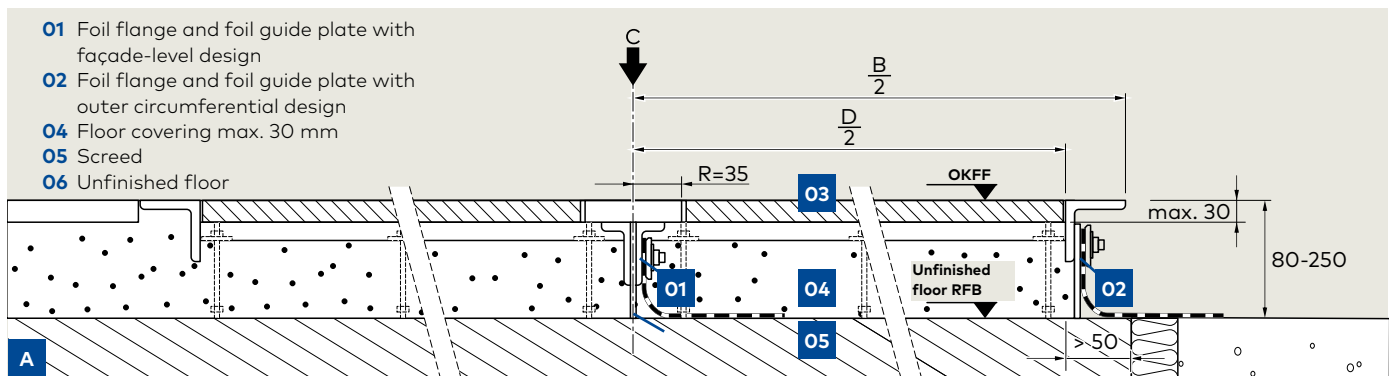
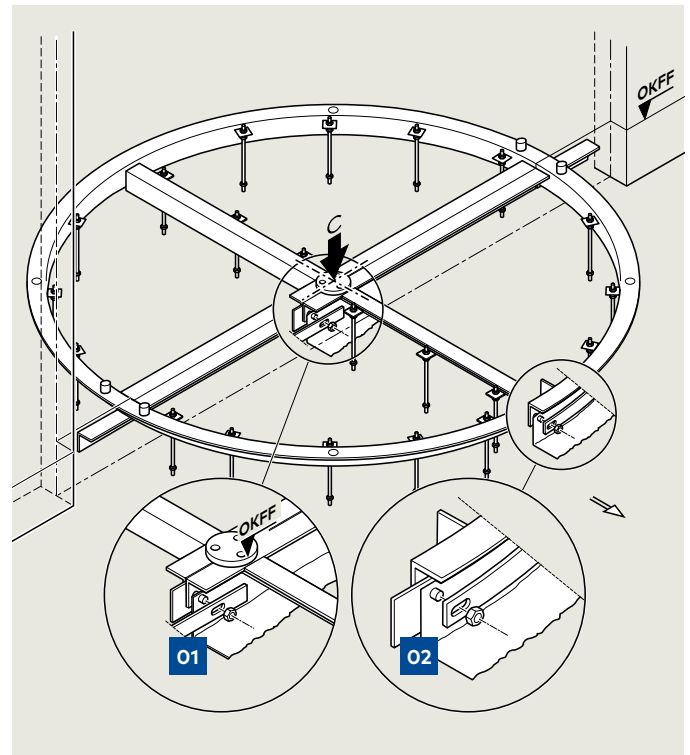
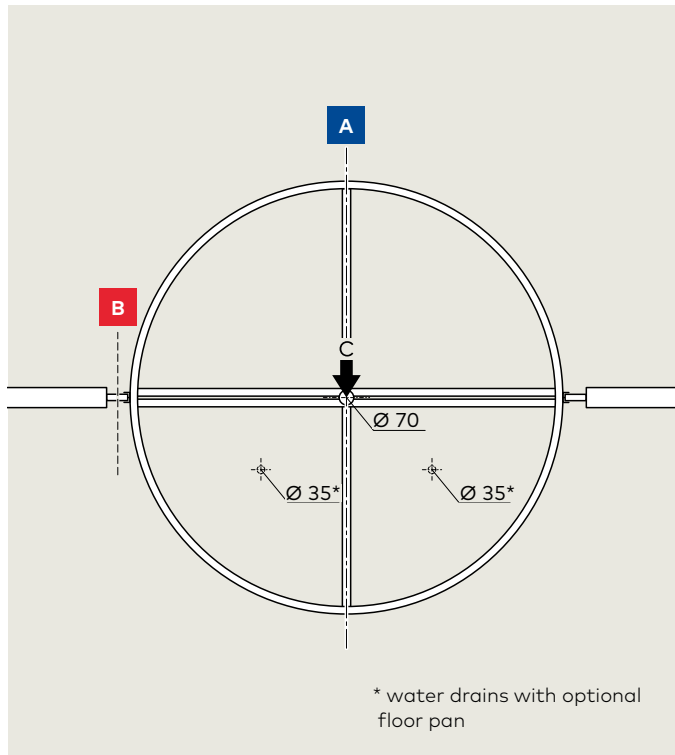

Version with sealing layer at centerline

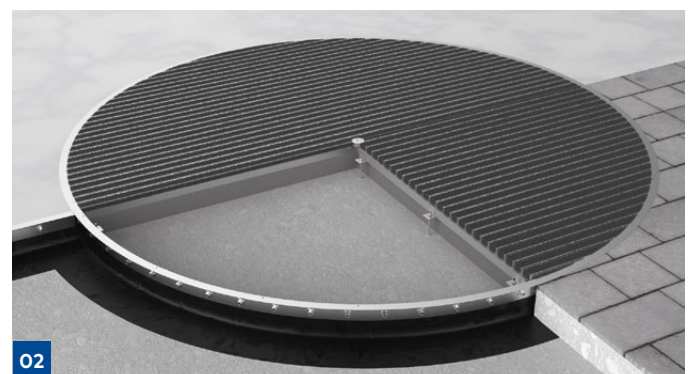

Version with outer half circumferential sealing layer

In new buildings and with inadequately finished floors, we recommend the installation of a floor ring that has been previously anchored in the unfinished floor and cast with screed. This type of installation provides additional options (for example: foil clamping flange, floor mat, shroud, floor pan, etc.) and is optimally designed for long-term, trouble-free operation of the system. For this purpose, the unfinished floor in the area of the floor ring must be designed as a single piece and extend at least 50 mm beyond the outer ring radius.

Alternatively, the door system may be installed directly on the existing floor if it is sufficiently stable and level (max. +/- 2 mm levelling difference over the entire system area).

Sealing and drainage of rainwater

To ensure sealing of the construction, a clamping flange can be attached to the floor ring to install on-site sheeting: either centrally on the façade level (01) or circumferentially around the outer half of the floor ring (02). This flange is available as a standard model or a model according to DIN 18195 Part 5. Optionally, an additional floor pan (06) with two DN35 water drains can drain away rainwater that enters the drum during driving rain. The position of the drains is freely selectable.

Floor covering inside the system

Entrance mats with a rubber or carpet inlay precisely co-ordinated to the revolving door are available ex works. On request, floor coverings or mats provided by others may also be considered. The height must not exceed 30 mm and must be specified when ordering the floor ring. Make sure that floors that have been added on-site meet the prescribed requirements with regard to quality (e.g. evenness and permissible rod spacings).

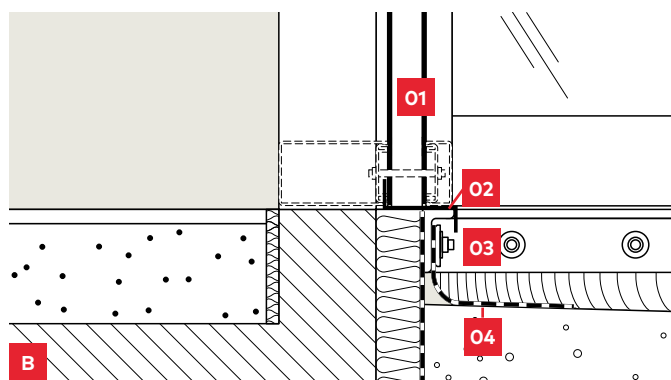

- 01 Façade connection profile
- 02 Z profile (on-site)
- 03 Foil clamping flange
- 04 Sheeting (on-site)

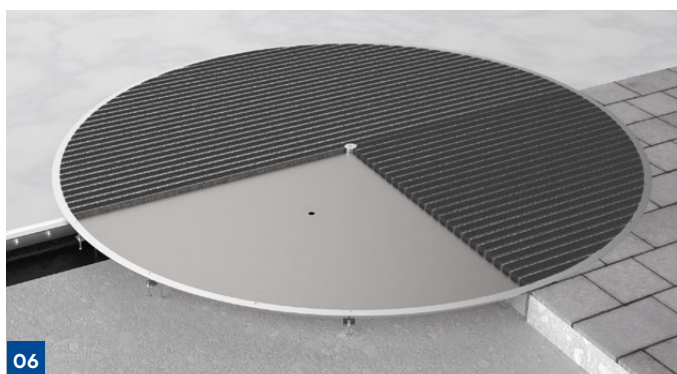

Version with sealing layer at centerline with optional floor pan

Façade and building connections

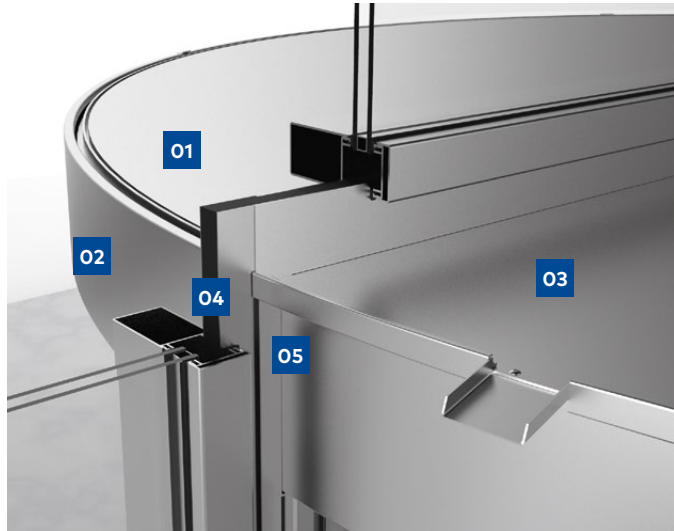

Each revolving door is individually planned. The connections to the façade and building are realised in consultation with the building or façade planner. The detailed drawings below display examples of revolving doors centrally installed at the façade level.

- 01 Dust cover
- 02 Canopy
- 03 Rain-proof metal sheet on top with water spout
- 04 Metal panelling (or according to architects specification)
- 05 Façade connection profile

Side connections

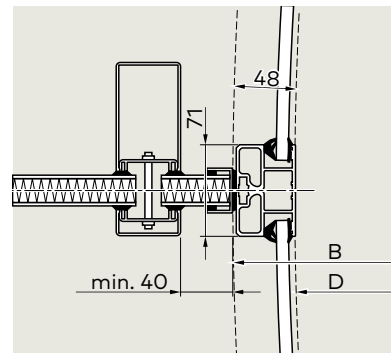
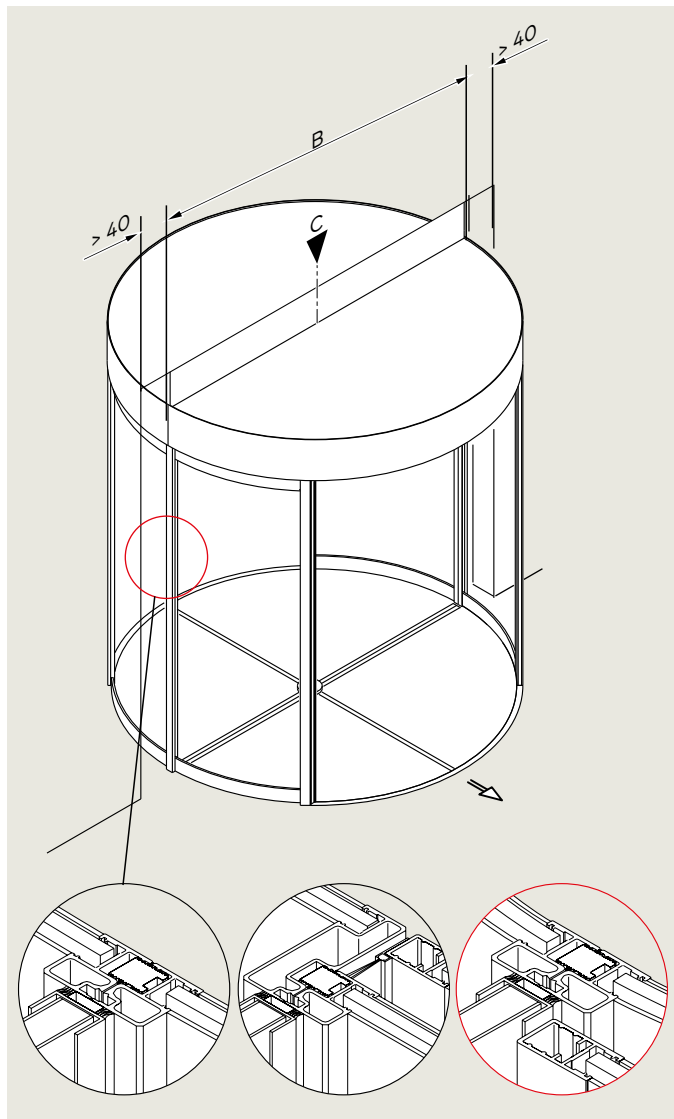

Version without night shield

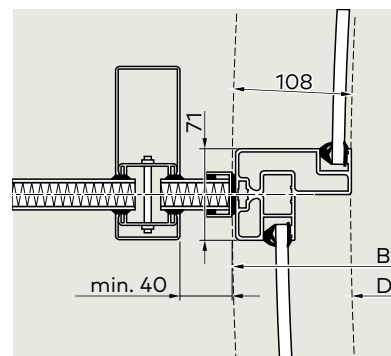

Version with internal night shield

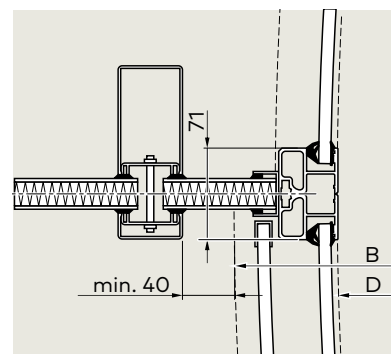

Version with external night shield

Ceiling connections and ceiling versions

Version with raised canopy

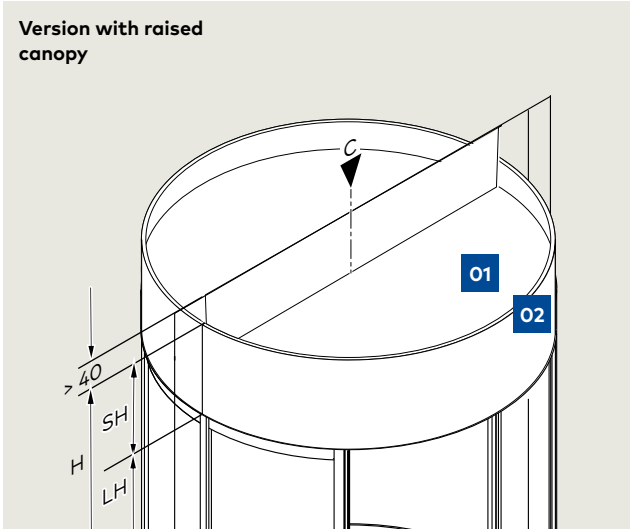

The upper ceiling is designed as a dust cover made of white melamine-coated chipboard, which can optionally be supplemented with additional sheets in a system-coordinated finish. It is also possible to design the upper ceiling as a rain-proof sheet-metal ceiling with lateral water spouts. Alternatively, the system can be prepared ex works for sealing with (bituminous) sheeting. The sealing work must be carried out as an on-site service.

- 01 Dust cover
- 02 Raised canopy
- 03 Metal sheet on top or rain-proof metal sheet on top

Version with dust cover and decorative sheet-metal lagging on the outside

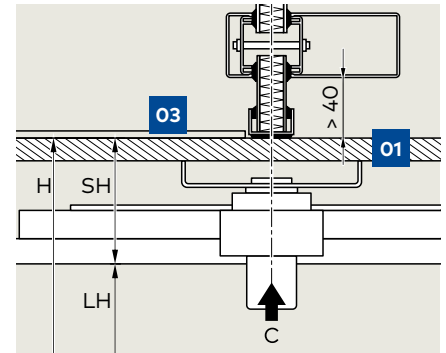

Version with dust cover and rain-proof sheet-metal lagging on the outside

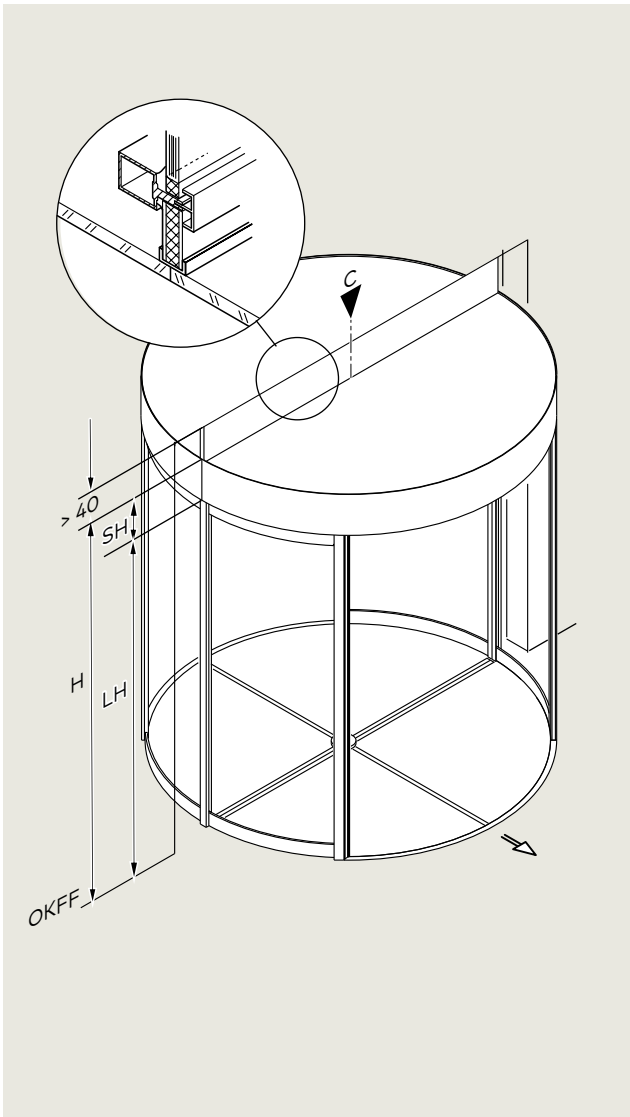
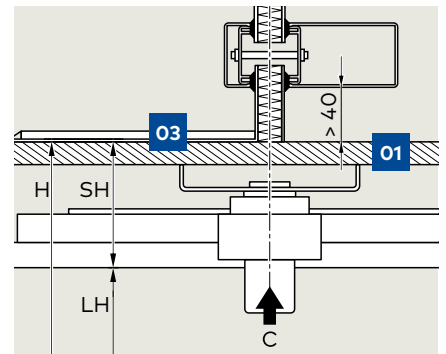

Safety equipment and functional elements

Depending on the operating mode and function module, different safety equipment is required and additional functions are possible. With a purely manual door without a function module, no safety equipment is required, but speed limiter unit is recommended. The necessary safety equipment must be clarified individually and in advance in accordance with the local requirements.

Revolving door with KTV P positioning automatic or KTV S servomatic (function module P or S /low-energy mode)



Operational safety in low-energy mode

Revolving doors with positioning automatic (KTV P) or servomatic (KTV S) are designed as a low-energy drive system. The drive power and rotation speed are reduced. Active safety sensors are not required, the opposing closing edges on the leading mullion are secured by impact protection strips. In addition, the drive can be stopped at all times using the emergency stop switch.

		KTV-P automatic positioning	KTV S servomatic
Safety equipment			
01	Impact protection strips on leading mullion inside/outside	●	●
02	Emergency stop switch	●	●
	inside	●	●
	outside	○	○
	Speed limiter (adjustable)	●	●
Functional equipment			
03	Handles	●	●
	Push handles (350 mm)	●	●
	Vertical/horizontal cross bars	○	○
Starting trigger	Manual push	●	-
	Movement sensor	-	●
	Manual acceleration to walking speed	●	●
	Program switch to select the operating mode	●	●
Locking device	manual	○	○
	electro-mechanical	○	○

● = standard equipment ○ = optional equipment - = not required/not possible

KTV-A automatic revolving door
(function module A/full-energy mode)

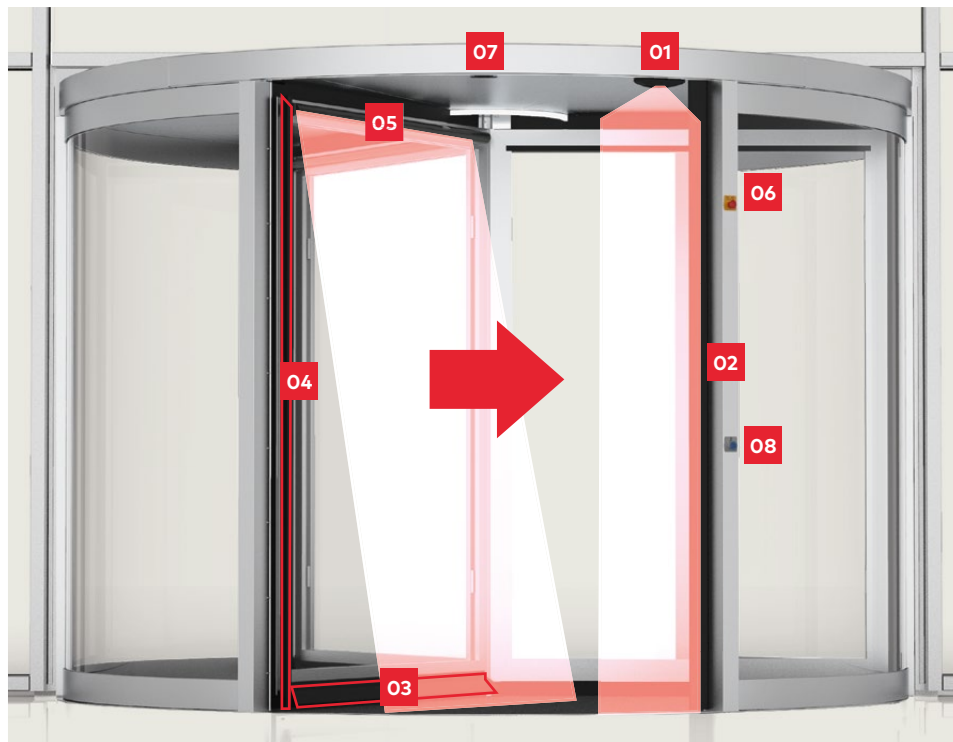

Catchword emergency stop switch

When the emergency stop switch is triggered, the door stops immediately. It can then be manually rotated in both directions. Resetting the emergency stop switch returns the door to normal operating mode

KTV A
automatic

Safety equipment

		EN 16005	Non-EU
01 Canopy sensors on leading mullion inside/outside	Laser	●	
	Infrared		●
02 Safety bumpers on leading mullion inside/outside	Impact protection strips	●	
	Active contact strips		●
03 Safety contact strips on wings horizontal, lower edge		●	●
04 Safety contact strips on wings, vertical, outer edge		●	
05 Pre-detection sensors on wings	inside diameter up to 3 m		○
	inside diameter > 3 m	●	○
06 Emergency stop switch	inside	●	●
	outside	○	○

Functional equipment

07 Internal/external movement sensors		●	●
08 Handicap button (slow rotation) inside/outside		○	○
Program switch to select the operating mode		●	●
Locking device	manual	○	○
	electro-mechanical	○	○

● = standard equipment ○ = optional equipment

Operational safety in full-energy mode

The revolving door is automatically operated and, if necessary, slowed down or stopped. Depending on the size of the system and the requirements to be fulfilled, various actuating and safety devices are used with the system:

- Movement sensors, start buttons, card readers
- Handicap buttons, emergency stop switch
- Active safety contact strips, passive impact protection strips
- Canopy safety sensors on the opposing closing edges (posts)
- Pre-detection sensors on the door wings

Air curtain system

An air curtain acts as an air barrier that minimizes heating and cooling costs. It is available as a ceiling or free-standing vertical version and is located on the inside door opening.

As an alternative to the standard equipment proposed ex works, a customized version may be required and developed in close consultation with the technical planners and the manufacturer of the air curtain, depending on the individual application.

Functionality

Air curtain devices are either designed as a hot water appliance for integration into the existing heating circuit of the building, or with electrically heated registers. The air is heated in the heating registers. The air volume and speed is controlled via an operating panel or remote control or integrated into the building management system. To keep the system efficient, the registers are protected against dust through air filters.

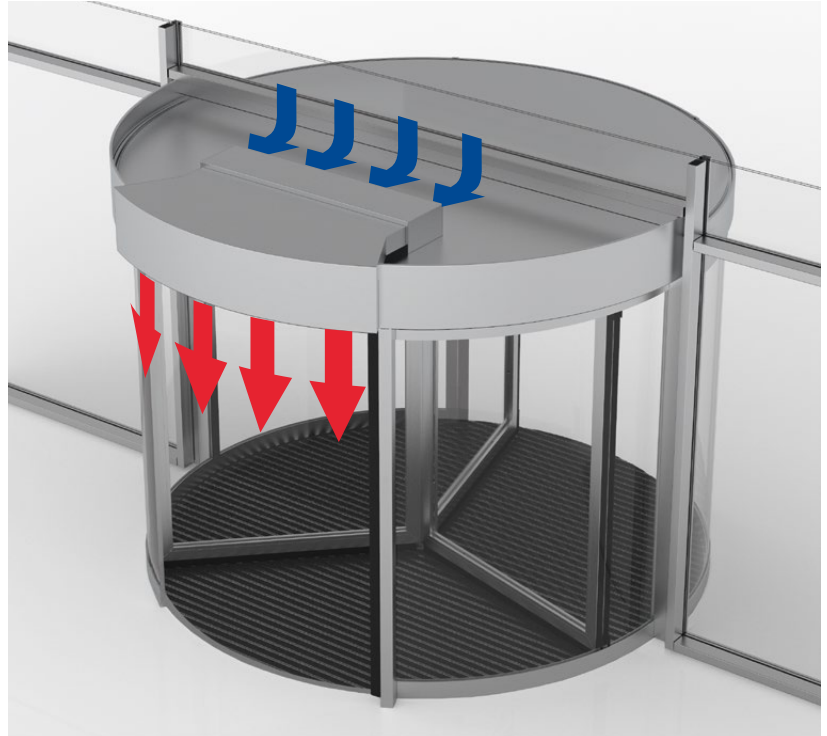

Ceiling design for horizontal air curtain

The appliance is surface mounted on the reinforced upper ceiling, which increases the canopy height to at least 400 mm, depending on the power requirement. The blower duct is located in front of the inner canopy. For maintenance purposes (e.g. filter replacement) sufficient working space should be provided above the door system.

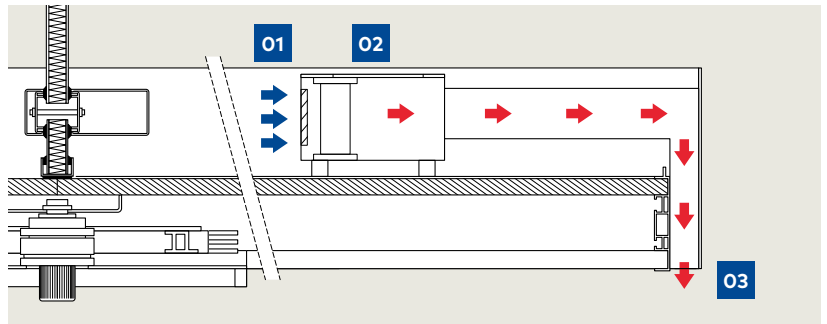

- 01 Air supply
- 02 Air curtain with dust filter and heating register
- 03 Blower duct
- 04 Supply/return line connection to existing heating circuit (optional)

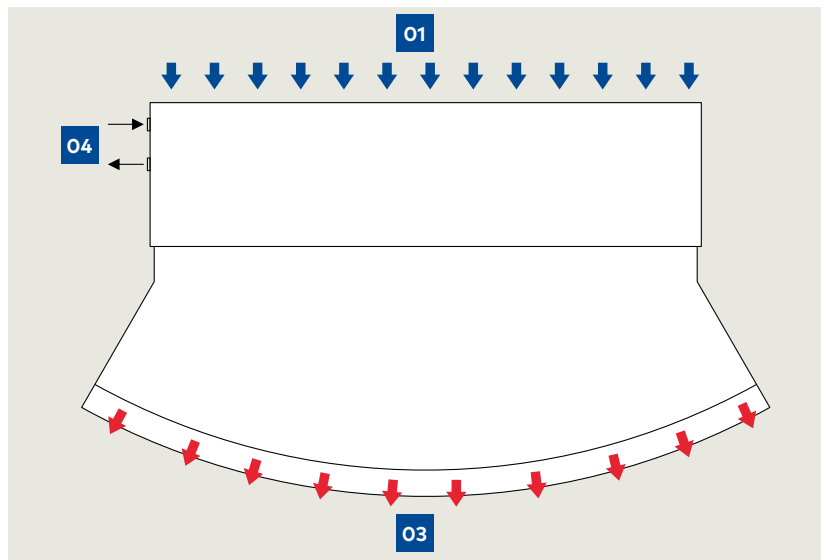

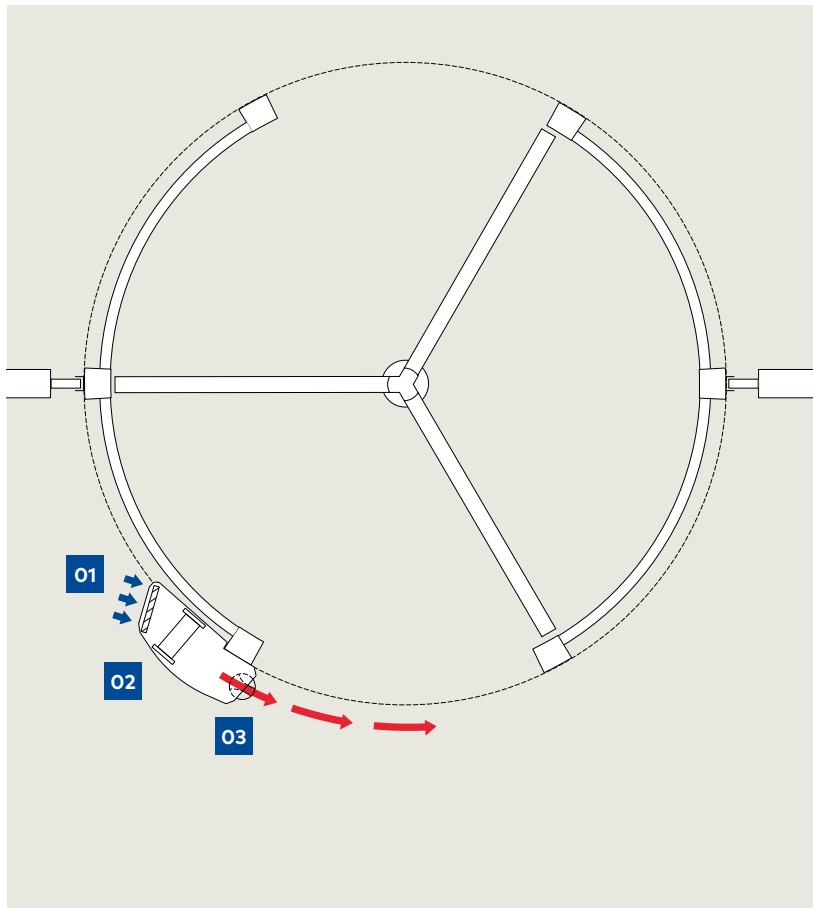
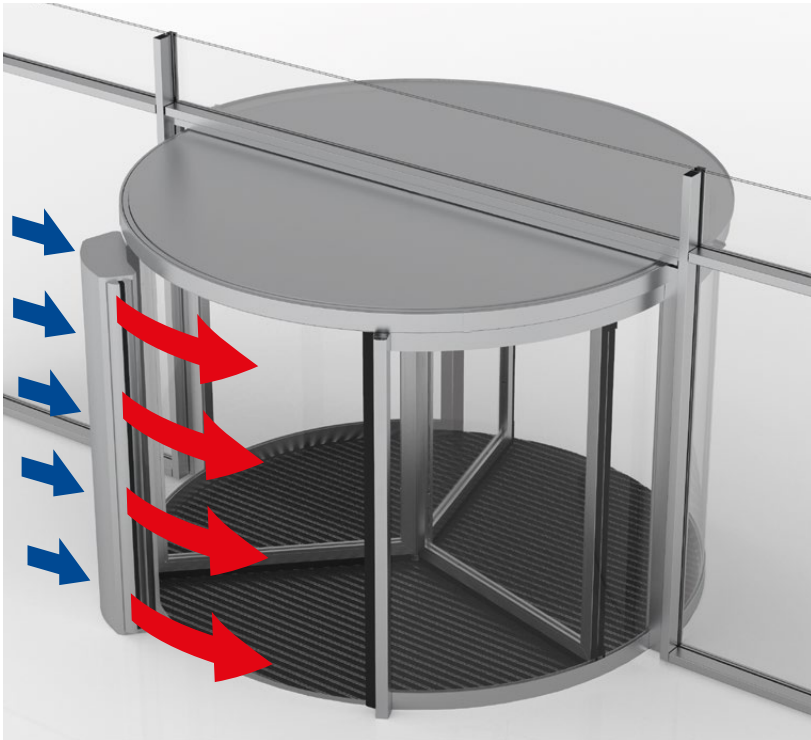

Free-standing vertical version for vertical air curtain

In the case of free-standing devices, the low canopy height of the revolving door is retained. A connection to a heating circuit can be made via floor lines. Alternatively, electrically heated appliances are also available in this design. Standing devices are particularly maintenance-friendly, as the components are easily accessible. Depending on the power requirement, two devices can also be combined. The exact dimensions depend on the power requirement.

- 01** Air supply
- 02** Air curtain with dust filter and heating register
- 03** Blower duct

Electrical connection



Depending on the equipment, different cables for the power supply and control unit must be provided on site for the electrical connection of the system. All cables must be able to be routed into the ceiling; a sufficient cable length must be taken into account.

Standard connections

- | | |
|---|---------------------------------|
| 01 Power supply for drive system | 3 x 1.5 mm ² / 220 V |
| Equipotential bonding | min. 6 mm ² |

If the system is not to be controlled from the post, the following cables must be provided on site:

- | | |
|---------------------------------|-------------------------------------|
| 02 Program switch | 5 x 0.75 mm ² |
| 03 Emergency stop switch | 2 x 0.75 mm ² |
| 04 Handicap button | 2 x 0.75 mm ² (optional) |

Connections for optional on-site technical building equipment

- | | |
|---|-------------------------------------|
| 05 Dry contact
(status message) | 2 x 0.75 mm ² (optional) |
|---|-------------------------------------|



Connections for air curtain

The exact connections are documented during the planning process. Depending on the version, a power supply, heating pipes (supply/return) for integration in the heating circuit of the building infrastructure as well as a control cable for connection to the building management system are required.

Uninterrupted power supply USV

The optional USV is dimensioned so that the system will remain operational for a certain time (several minutes) in the event of a power loss, independent of the mains voltage. During this time, the building can be left in order to move the turnstile and any night shield to the locked position.

KTV equipment and combinations at a glance

Number of door wings	3 (KTV 3) or 4 (KTV 4)
Diameter	2,000–3,800 mm
Clear passage height	2,100–4,000 mm
Canopy height	100–1,000 mm
Total height	2,200–5,000 mm

Body

Aluminium profile frame system, filling with curved safety glass (laminated safety glass, toughened safety glass, P4A, clear glass) or sandwich metal panelling.

Ceiling assembly

Aluminium canopy profile with sheet-metal cladding in system-coordinated finish; upper ceiling with dust protection cover, decorative metal sheet on top, rain-proof metal sheet on top or prepared for on-site sealing with (bituminous) sheeting; lower ceiling made of melamine-coated multi-layer plates or from sheet-metal segments coated with system-coordinated finish.

Door wing

Elegant circumferentially framed aluminium profile frame systems, safety glass panes (toughened safety glass, laminated safety glass, P4A, clear glass), rigid or collapsible door wings (bookfold/break-out or transport opening), "Twin-Brush" double layer brush sealing system.

Alternative: rigid fine-framed wings made of 12-mm toughened safety glass, 3-sided with no visible profiles in the door centre.

Surfaces

Powder-coated in RAL glossy or matt colour grades, NCS or DB, anodized tones according to EURAS colour grades, e.g. E6-CO/EV1.

Alternative: stainless steel sheet metal cladding with brushed or polished finish, increased corrosion protection or special surfaces.

Floor ring

Stainless steel floor ring, can be fitted on site without welding, optionally with clamping flange, shroud, floor pan or entrance mat. Panels supplied ex works for professional casting on the construction site.

Alternative: installation without floor ring on finished floor.

Drive system	none		KT FLEX Direct		
Function module	none	none	module P	module S	module A
Operating mode	manual	speed limiter	positioning automatic	servomatic	automatic
Start rotation	manual	manual	manual	automatic	automatic
Acceleration to walking speed	manual	manual	manual	manual	automatic
Speed limiter		●	●	●	
Automatic speed control					●
Automatic positioning in rest position			●	●	●
Low-energy drive acc. to EN 16005			●	●	
Safety sensors acc. to EN 16005					●
Emergency stop switch			●	●	●
Handicap button (slow rotation)					○
Manual locking device for door wing	○	○	○	○	○
Electro-mechanical locking device for door wing			○	○	○
Manual night shield (internal or external)	○	○	○	○	○
Burglary-resistance class RC2	○	○	○	○	○
Automatic night shield	○	○	○	○	○
Night/bank function					○
Air curtain	○	○	○	○	○
Locking status contacts	○	○	○	○	○
Interface for door status signals		○	○	○	○
External interface (diagnostics and parameter setting)		●	●	●	●
Vertical handles	●	●	●	●	
Vertical or horizontal cross bars	○	○	○	○	
Lighting	LED recessed spotlights	LED light ring	LED light ring	LED light ring	LED light ring
Certificates			EN 16005	EN 16005	EN 16005
Proven durability (cycles)	2 million	2 million	2 million	2 million	2 million

● = standard equipment ○ = optional equipment - = not required/not possible * = dependent on the selected equipment

Your dormakaba partner:

Would you like to have a special feature that is not included as standard with our systems?
Contact us at: We'll coordinate with our application technology department to find a suitable solution.

WN 05344751532, 03/22, KTV 3 / KTV 4, EN
Subject to technical modifications without notice



Door Control



**System Solutions
Access and Time**



**Mechanical
Lock Systems**



**Automatic
Door Systems**



Glass Systems



Service

dormakaba Deutschland GmbH

DORMA Platz 1
D-58256 Ennepetal
T +49 2333 793-0
info.de@dormakaba.com
www.dormakaba.de

dormakaba Austria GmbH

Ulrich-Bremi-Strasse 2
A-3130 Herzogenburg
T +43 2782 808-0
office.at@dormakaba.com
www.dormakaba.at

dormakaba Schweiz AG

Lerchentalstrasse 2a
CH-9016 St. Gallen
T +41 848 85 86 87
info.ch@dormakaba.com
www.dormakaba.ch