

## F Note importante

1. La tension d'alimentation doit être suffisante. Voir la notice de raccordement
2. L'alimentation doit fournir un courant suffisant
3. Ne jamais percer ni modifier le verrouillage EM ni la contre plaque

1. The power supply has to be enough for the electromagnet. Look at wiring notice
2. The supply should be able to provide a sufficient voltage
3. The armature plate and the electromagnet should no be drilled or modified

**Important notice** **GB**

## F Installation type sur une porte en aluminium

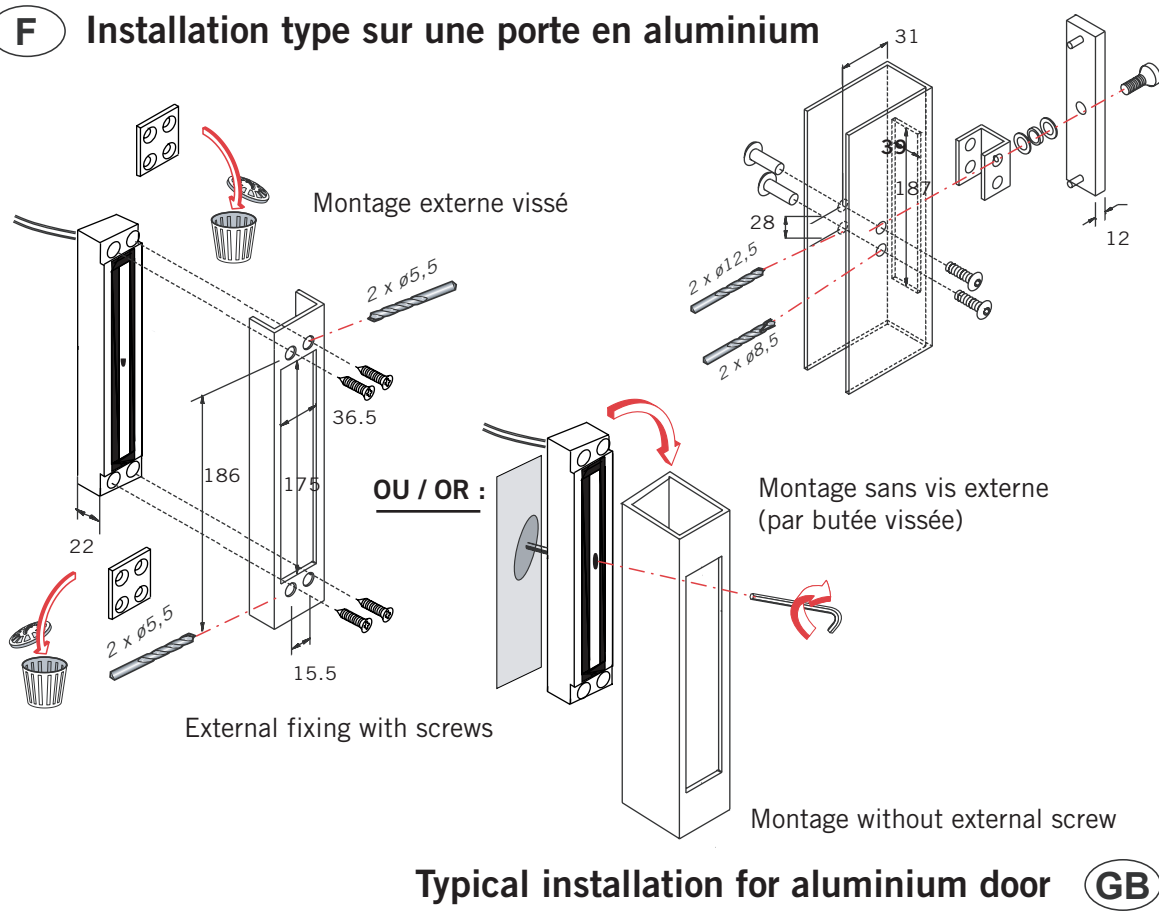

**Typical installation for aluminium door** **GB**

## F Installation type sur une porte en bois

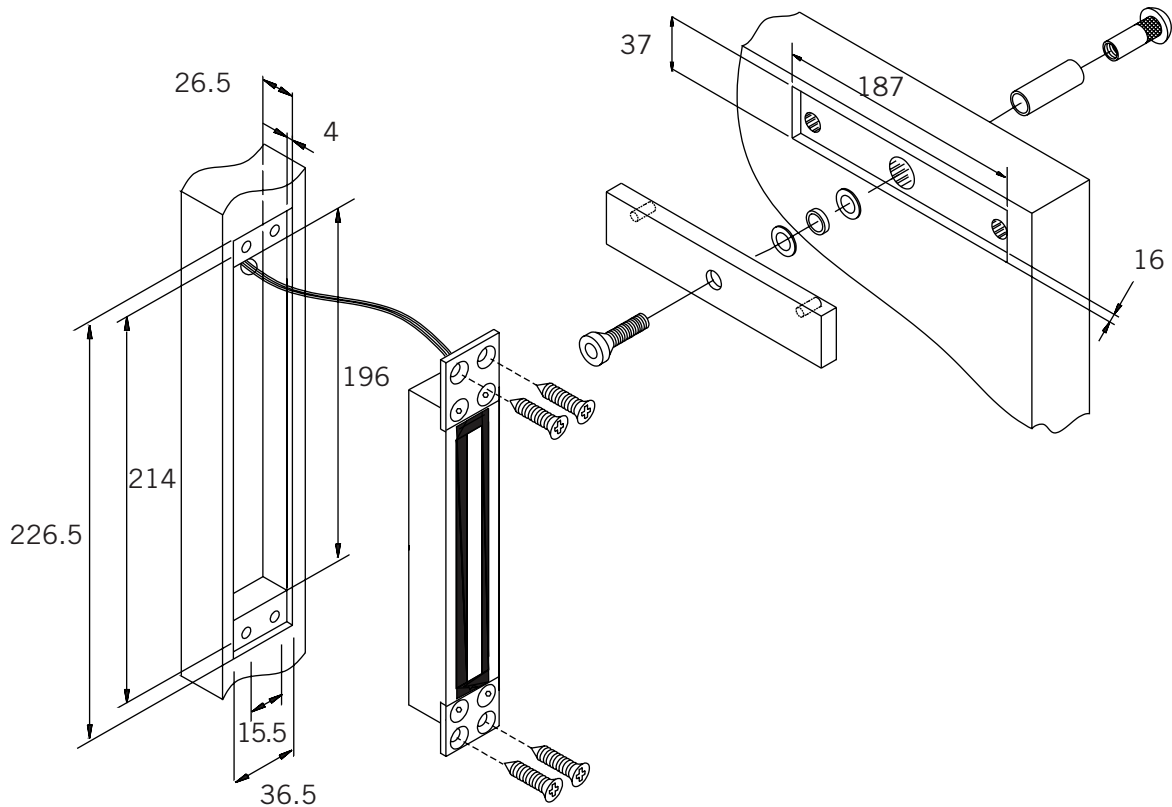

Typical installation for wooden door **GB**

## F Pose de la contre plaque sur porte en bois ou aluminium



La contre plaque doit être montée selon les dessins ci-dessous  
Ne pas serrer trop fort la vis centrale afin que la plaque reste souple

Porte en bois

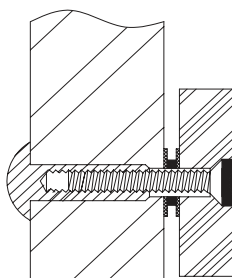

Wooden door

Porte aluminium  
ou PVC

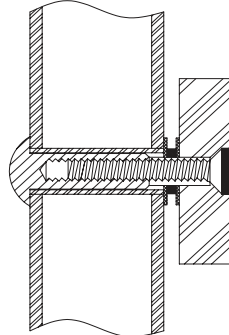

Aluminium  
or Plastic door

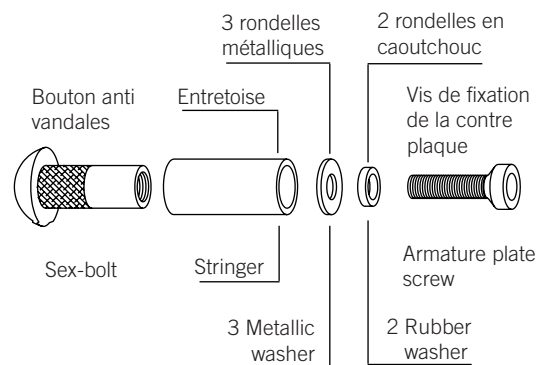

The armature plate should be mounted as shown above.  
Do not over-tighten the central screw. The plate must remain flexible

Mounting of the armature plate on a wooden or aluminium door **GB**