

4000 Mortise Lock

Installation Instructions

Programmable Pushbutton Lock

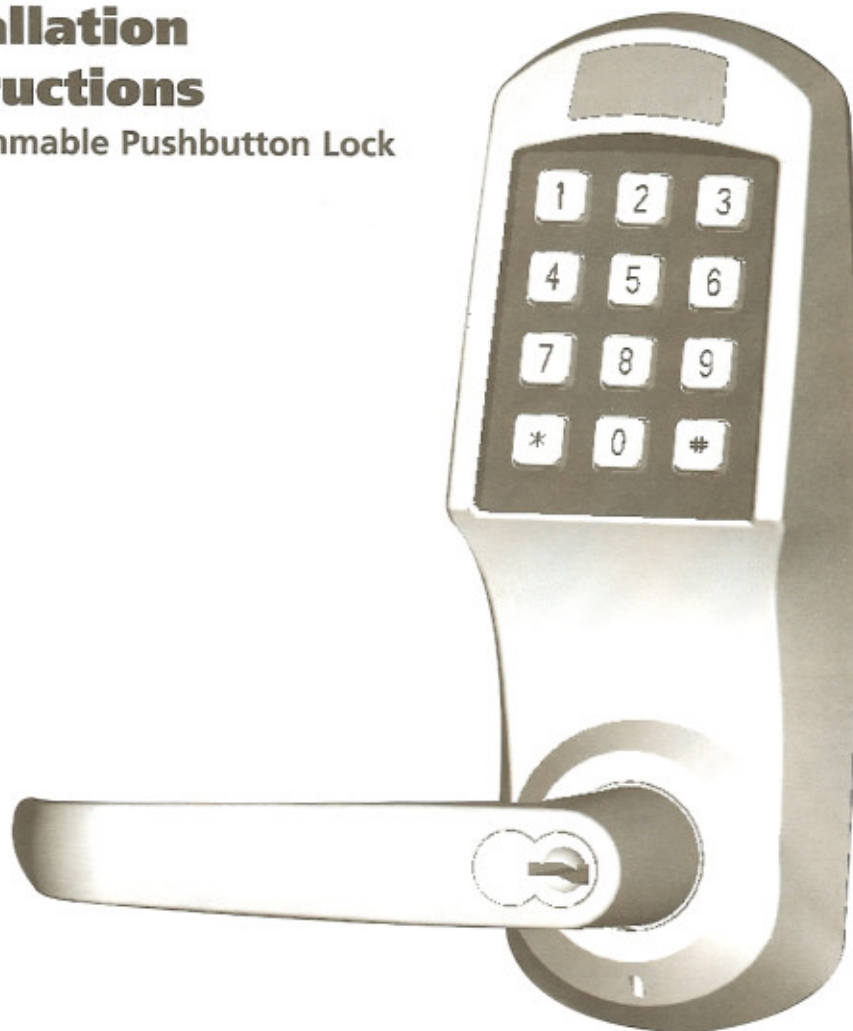

Warning

The combination of this lock has been factory preset to 4000. For your security, both master authorization code (12345678—factory default) and preset service access code (4000) must be changed by the end user soon after the lock is installed.

IMPORTANT

For your protection, return the warranty card located in the center of this manual.

 **KABA®**

Lock Installation

4000 Mortise Lock

Warning

The combination of this lock has been factory preset to 4000. For your security, both master authorization code (12345678—factory default) and preset service access code (4000) must be changed by the end user soon after the lock is installed.

Important:

For your protection, return the warranty card located in the center of this manual

1.1 Introduction

The Ilco Unican 4000 Mortise Electronic Lock (see Figure 1) is designed to be installed in a standard mortise lock cutout. The mortise lock can be mounted in wood or metal doors $1\frac{1}{8}$ " to $2\frac{1}{2}$ " (35 to 63 mm) thick without adapters. You may require the 1" (25 mm) mortise face plate for doors measuring less than $1\frac{1}{8}$ " (44 mm) thick.

Other than a standard mortise cutout, the only additional door cutouts needed to mount the lock are four holes for the mounting screws, a hole for the reader cable.

Note: The Mortise pocket may have to be enlarged if required.

Mortise lock package contents:

- Outside lock housing assembly
 - Inside housing assembly
 - Inside housing cover assembly
 - Inside lever handle
 - Mortise lock with face plate
 - Strike plate
 - Dust box
 - 2 steel combination screws
 - 2 brass combination screws
 - 2 8-32 x $\frac{1}{8}$ " screws
- Hardware bag containing the following:
 - Battery holder assembly (1)
 - #6-32 X $\frac{1}{8}$ " hex socket capscrew (2) for bottom end cap
 - #10-24 mounting screws (4) $2\frac{1}{2}$ " long for $1\frac{1}{8}$ " door thickness
 - #10-24 mounting screws (4) $2\frac{3}{4}$ " long for $1\frac{3}{8}$ " door thickness
 - #10-24 mounting screws (4) $3\frac{1}{2}$ " long for 2" door thickness
 - #8-32 X $\frac{1}{8}$ " hex socket set screw (1) for inside lever
 - Aligning stud (1)
 - Allen key $\frac{3}{16}$ " (1)
 - Front face plate EPBL (1)
 - Gasket for inside housing assembly (See important on page 6)

Tools Needed:

- Phillips #2 screwdriver
- Allen keys: $\frac{1}{8}$ " for the set screw
 $\frac{3}{16}$ " for bottom end cap screw & inside lever screw
- Drill bits: $\frac{1}{8}$ " (6.5mm), $\frac{3}{16}$ " (22.5mm), $1\frac{1}{8}$ " (32mm)
- Mortising machine (optional)
- Chisel
- Hex socket $\frac{3}{16}$ " or adjustable wrench
- Steel file (medium or fine)

Figure 1

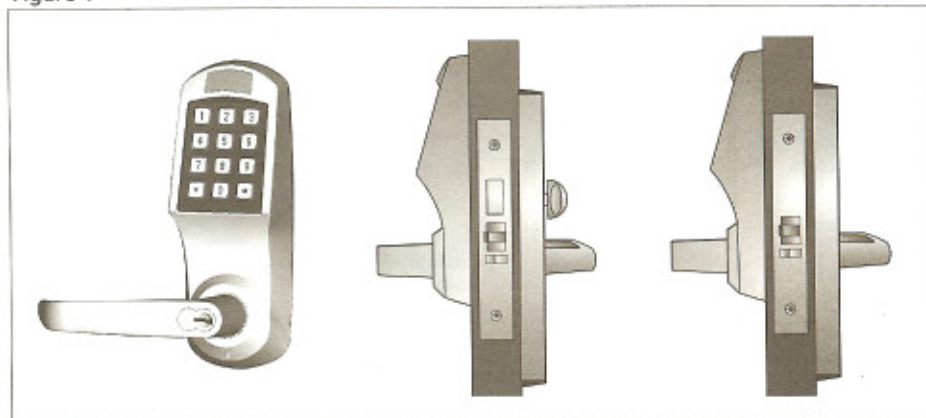

With Deadbolt

Without Deadbolt

1.2 Checking the Door

Proper alignment of the door with the frame and the lock with the strike are crucial for the performance and durability of the lock. On pairs of doors with overlapping astragal* or rabbeted edges ensure that all auxiliary hardware, such as: flush bolts, vertical rod panic devices, door closers, and door coordinators, is installed correctly (see Figure 2). Rabbeted doors may require a different mortise.

*An astragal is a strip running the length of the passive door opposite the hinges (see Figure 3).

Make sure the lock hand and door hand are the same (see Figure 4).

1.3 Marking the Door

- 1) Using the drilling template D1-PKG-2690 for Mortise Lock 1 1/4" (32 mm) Face Plate, or D8-PKG-2622 for European Mortise Lock with 23 mm Face Plate, establish the proper lock mounting height on the door according to local industry standards.
- 2) Place the template on the door edge and line up the centerline of the lock face on the template with the center of the door thickness.
- 3) Mark the outline of the lock face and the outline of the mortise cutout for the lock body.
- 4) Mark the axis of rotation so you can line up the template on the door face.
- 5) Remove the template, fold where indicated and reposition the template with the fold on the exterior corner of the door edge. Make sure the axis of rotation lines up with the axis of rotation marking on the door edge.
- 6) Mark the holes to be drilled with a punch on the exterior face of the door.
- 7) Remove the template, fold on the other fold line and reposition the template with the fold on the interior corner of the door edge. Make sure the axis of rotation lines up with the marking on the door edge.
- 8) Mark the holes to be drilled with a punch on the interior face of the door.

Keep the template aligned with the lock mounting height line at all times.

1.4 Making the Mortise Cutouts

- 1) Using a lock mortising machine, or by drilling a series of 1" (25 mm) holes make the 4 1/4" (11 cm) deep mortise cutout in the door edge. For European Mortise case, use 3/8" (16 mm) holes.
- 2) Place the mortise in the cutout to ensure that it is a proper fit. Remove the mortise.

Figure 3

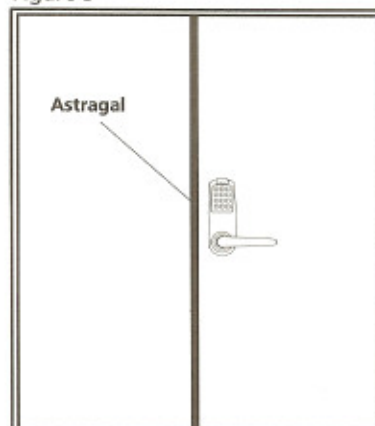

Figure 2

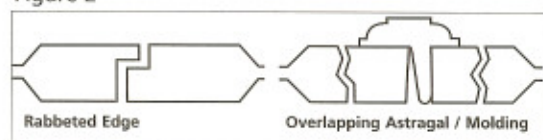
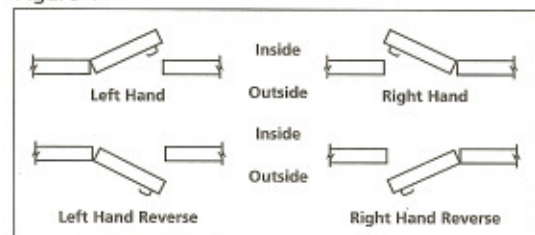

Figure 4



- 3) Use a router to make a $\frac{1}{8}$ " (6 mm) cutout inside the previously marked outline for the mortise face plate. For European Mortise, use $\frac{3}{16}$ " (5 mm) holes.
- 4) Use a chisel to make the anti-friction cutout.
- 5) Drill the mortise mounting screw holes.

1.5 Making the Electronic Lock Cutouts

- 1) Starting on the inside of the door, drill the required holes on each side of the door as per the template.
- 2) Clean out the mortise cutout, so no objects interfere with its mechanism.

1.6 Installing the Mortise Lock

Note: Mortise locks ($\frac{1}{8}$ " thick case only) being installed on hollow metal doors may require the use of a stabilizing bracket. (part #: 50567701045 not included) The stabilizing bracket is placed on the end of the mortise lock, and is to be used in doors without lock brackets to prevent the door from collapsing on the lock. See Figure 5A.

- 1) Examine the bevel on the mortise. If the bevel on the mortise is incorrect, loosen the bevel adjusting screws, adjust the front for the correct bevel, and tighten the screws.
- 2) Remove the face plate from the mortise lock.
- 3) Place the mortise lock into the door cutout. Make sure that the mortise is positioned with the latch bolt above the auxiliary latch (see Figure 5).
- 4) Fasten the mortise in place using the steel combination screws provided (see Figure 5).
- 5) Make sure the latch moves freely in the lock and in the door.
- 6) Fasten the faceplate with the two 8-32 x $\frac{1}{4}$ " screws provided.

Figure 5

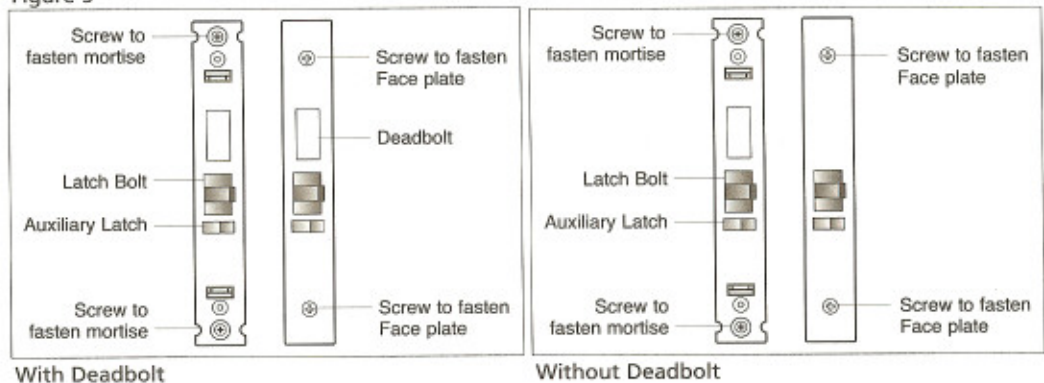
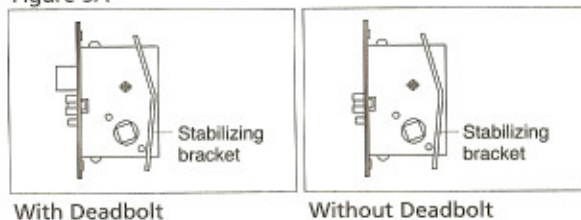

Figure 5A



1.7 Adjusting the Lock

for doors 1 1/2" (35 mm) thick

The 4000 Series lock has been assembled at the factory to accommodate doors 1 3/8" (44mm) thick.

For doors 1 1/2" (35 mm) thick, adjust the lock as follows:

- 1) Remove the C-Clip (see A in Figure 6) from the flat override shaft attached to the inside housing assembly.
- 2) Carefully break away the flat override shaft (see B in Figure 6) protruding from the square spindle. Use a file to remove the burr and bevel the four edges of the tip.
- 3) Remove the square spindle (see C in Figure 6) and use a hand saw to remove the cut-away piece (D) marked on the spindle. Use a file to remove the burr.
- 4) Re-install the spindle onto the inside housing assembly.
- 5) Re-install the C-Clip (see A in Figure 6) onto the override shaft in its previous position.
- 6) **Important:** If the lock is mounted in a condensing environment, we recommend using gasket (W) (see Figure 6A). After adjusting the lock, peel the polyester adhesive from the gasket and carefully stick the gasket starting from face A of inside housing assembly. Bottom face of gasket should be in line with face A of inside housing assembly.
- 7) Use two mounting screws 2 1/2" length to attach inside housing on outside housing.
- 8) **Thick door version** for doors over 2" (51 mm) to 2 1/2" (64 mm) thick.

The 4000 Series can also be installed on doors over 2" (51 mm) to 2 1/2" (64 mm) thick. For ordering information, contact your local ILCO UNICAN dealer.

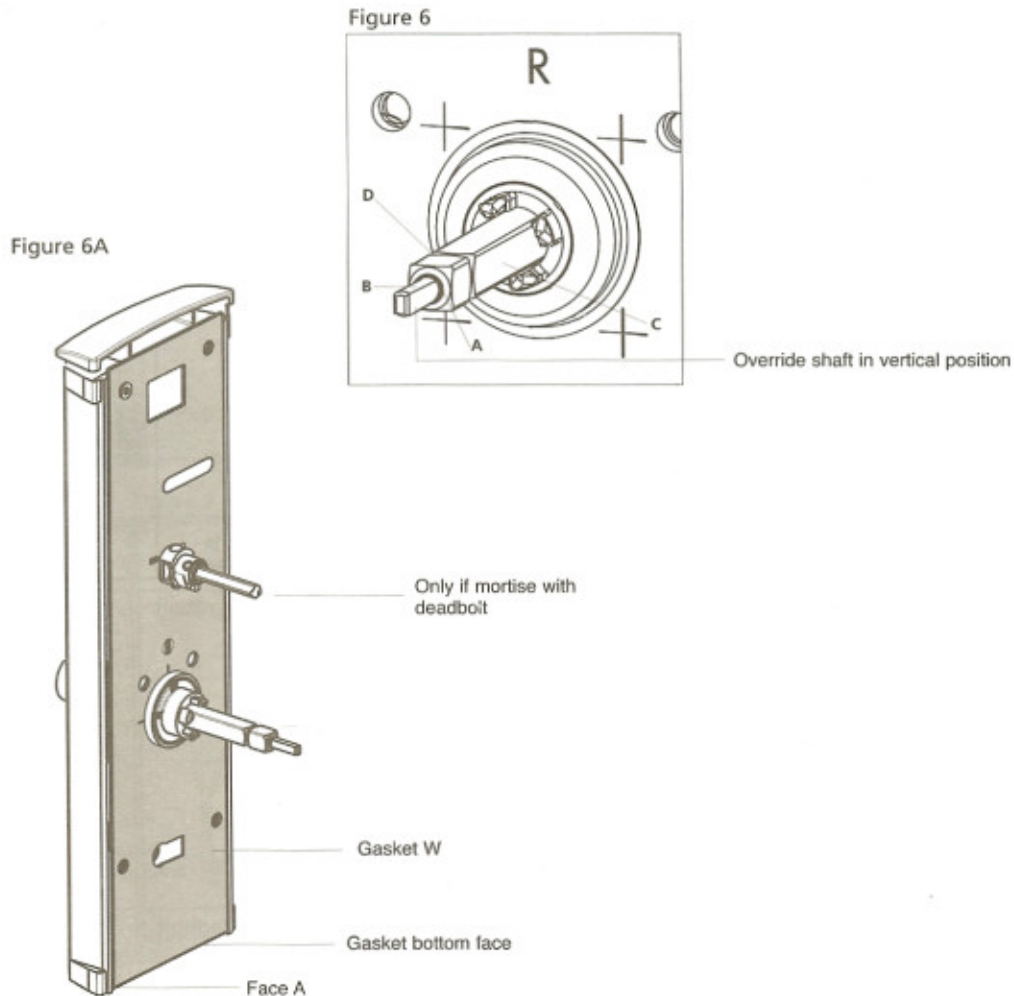

1.8 Installing the Electronic Lock

All locks have a mechanical override. The override is operated by a key and cylinder.

The following instructions must be carried out with the door open.

Lock Housing Preparation

- 1) Position the aligning stud (A) on the outside housing based on the handing of the lock (see Figure 7). Screw it 2 or 3 turns only, do not tighten.
- 2) Set the latch hub drive (B) on the inside housing to the proper position for the handing of the lock. Make sure the position of the spindle and override shaft is as shown (see Figures 8 and 9).
- 3) On outside housing assembly, ensure that the I/C Core mating part (pins or protrusions or slot) located on the outside lever, is in the vertical position (see Figure 9A).

Figure 7

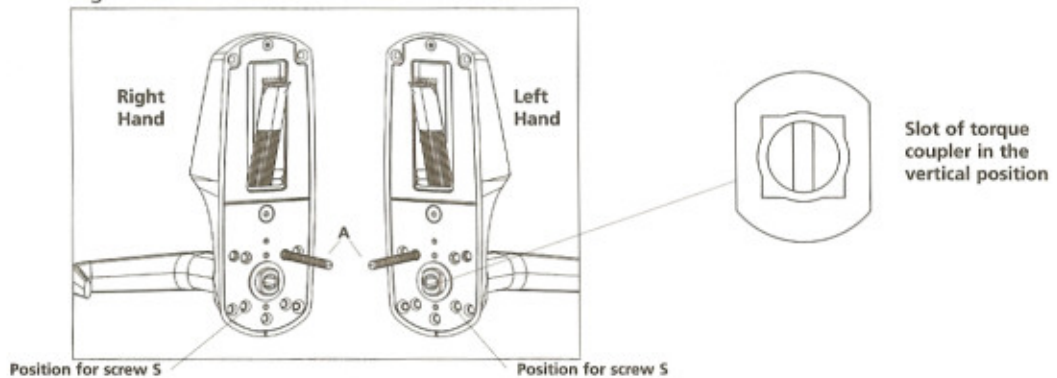

Figure 8

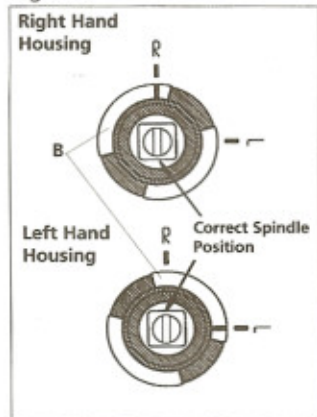

Figure 9

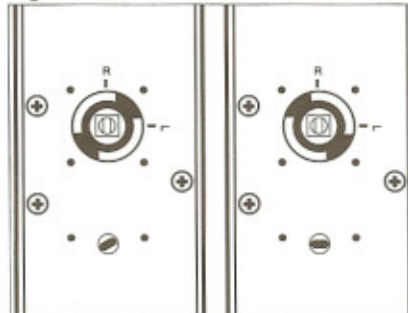
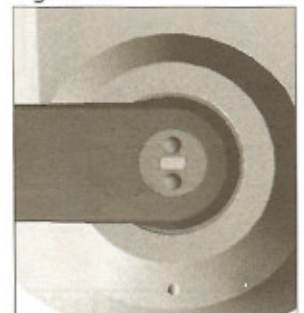

Figure 9A



Installing the Lock on the Door

Important: If the lock is mounted in a condensing environment we recommend the use of gasket W as shown in Figure 6A on page 6. After adjusting the lock, peel the polyester adhesive from the gasket and carefully stick the gasket starting from face A of inside housing assembly. Bottom face of gasket should be in line with face A of inside housing assembly.

- 1) Before assembling the outside housing on the door, press the reset button inside the housing (see Figure 9B) for a period of 10 seconds. Insert the aligning stud (A) on the outside housing through the hole in the mortise lock. Thread the reader cable (F) through the reader cable hole and mount the housing on the door (see Figure 10).
- 2) Connect the reader cable to the inside housing. Make sure the connector is fully engaged.
- 3) Mount the inside housing on the door. The entire reader cable should be inside the reader cable hole. Make sure it is not pinched between the door and the lock.
- 4) Mount the 2 long 10-24 screws S at the top and 1 in the hole opposite to stud (A) (See figure 7). Do not tighten them. Remove the aligning stud (A) and replace it with the 4th screw S. (See figure 10 & 11)
- 5) Using the inside lever to turn the inside lever drive tube (G), retract the latch bolt. This will ensure the latch hub drive is properly engaged with the mortise latch hub (see Figure 10). If latch retracts, tighten the 4 screws (2 on top and 2 at the bottom).
- 6) Install the removable core and test the operation of the mechanical keys. See section 1.9 Using the mechanical key override. The rotation should be very smooth. When the key is rotated 90° verify that the outside lever retracts the latch bolt. Return the key to initial position and verify that the outside lever does not retract the latch bolt. **Do not turn the key and the lever at the same time. First, turn the key 90°, then turn the lever. (See section 1.9)**
- 7) Secure the inside lever (L) with the set screw (M). Tighten the screw using the 3/16" (2 mm) Allen key. Insert the battery holder assembly (N) into the housing and secure it with the 6-32 X 1/2" hex socket cap screws (P) (see Figure 12). When you connect the batteries, you should hear the motor run for a short period of time, the buzzer, and you see the green light. If you do not, replace the batteries. Any time the battery is disconnected from the lock, a 3 second pause is required before reconnection. If the lock motor runs constantly, disconnect and then reconnect the battery (do not forget the 3 second pause). If the lock motor runs constantly after the battery is reconnected, replace the lock.

Figure 10

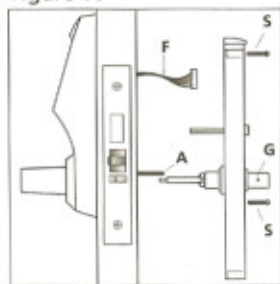

Figure 11

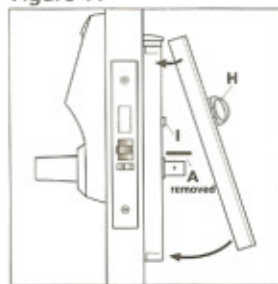
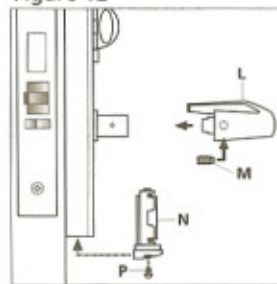
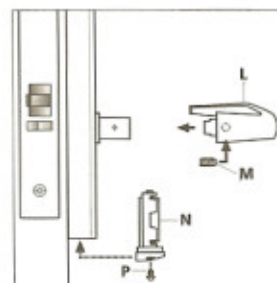
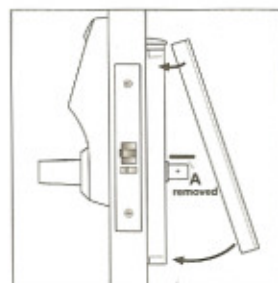
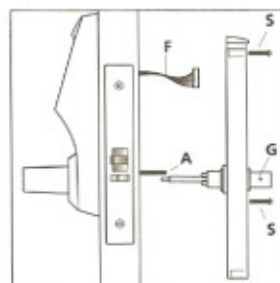

Figure 12



With Deadbolt and Thumbturn



Without Deadbolt and Thumbturn

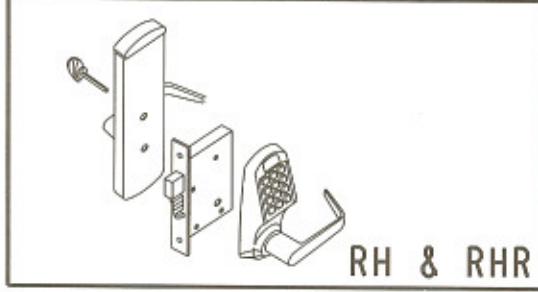
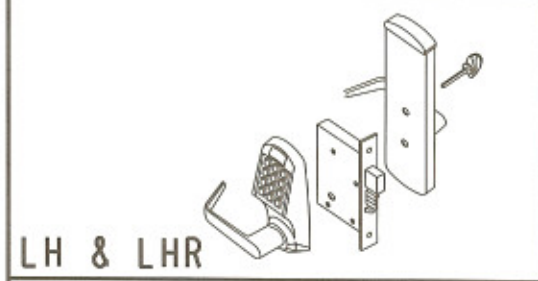
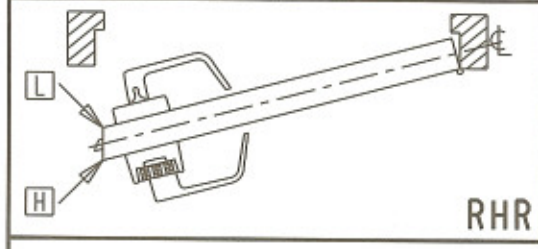
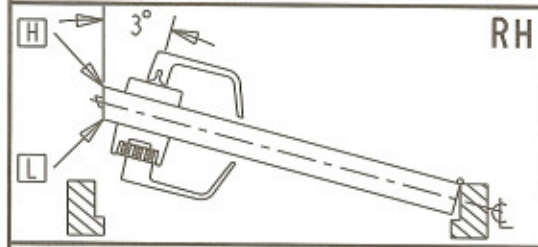
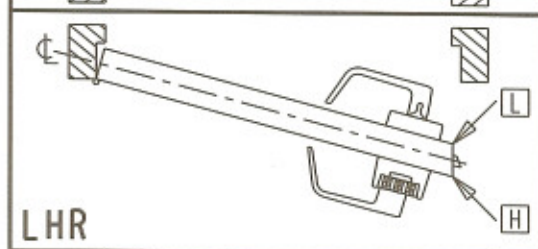
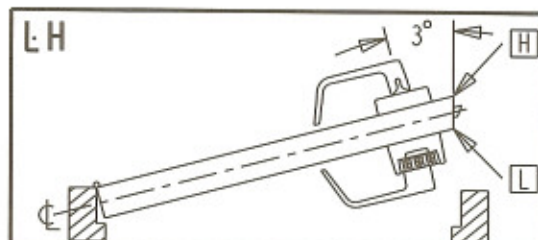
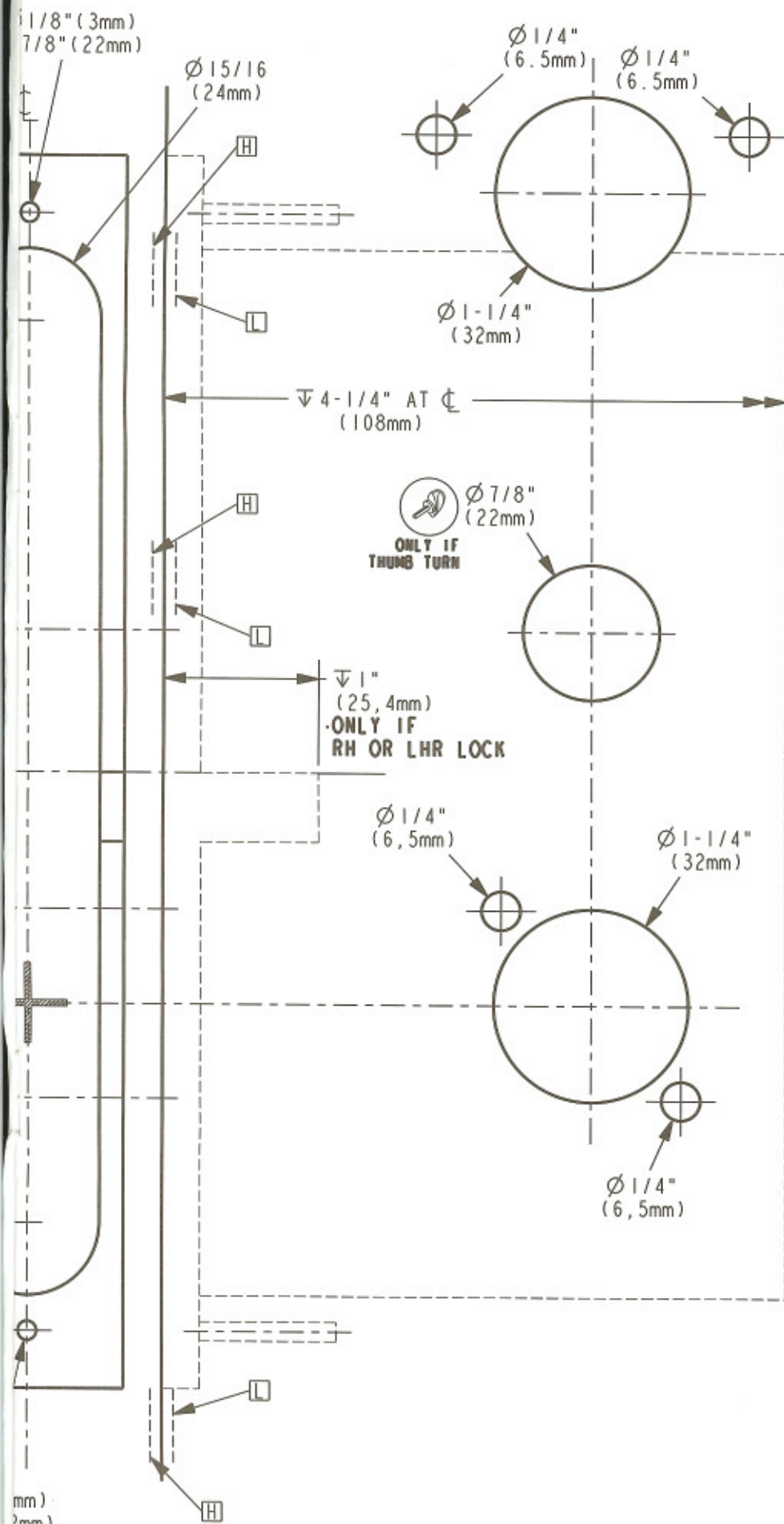

KABA
ilco
 7301, Decarie Boul
 Montreal, QC Canada
 H4P 2G7
 www.kaba-ilco.com

DRILLING TEMPLATE
ORACODE 610, EPBL 4000
 AMERICAN MORTISE - 1-1/4" FRONT PLATE
 LEFT HAND (LH) - LEFT HAND REVERSE (LHR)
 RIGHT HAND (RH) - RIGHT HAND REVERSE (RHR)
 BACKSET OF: 2-3/4" (70mm)

DT-509258 SHEET 1 OF 1 REV-3 ECN-10088

NOTES:

- FOR DIMENSIONS AND TOLERANCES REFER TO: DOOR PREPARATION DRAWING #IP-508965
- HIGH AND LOW BEVEL EDGE **H** **L** FOR DOORS WITH 3° BEVEL ANGLE (SEE ILLUSTRATION)

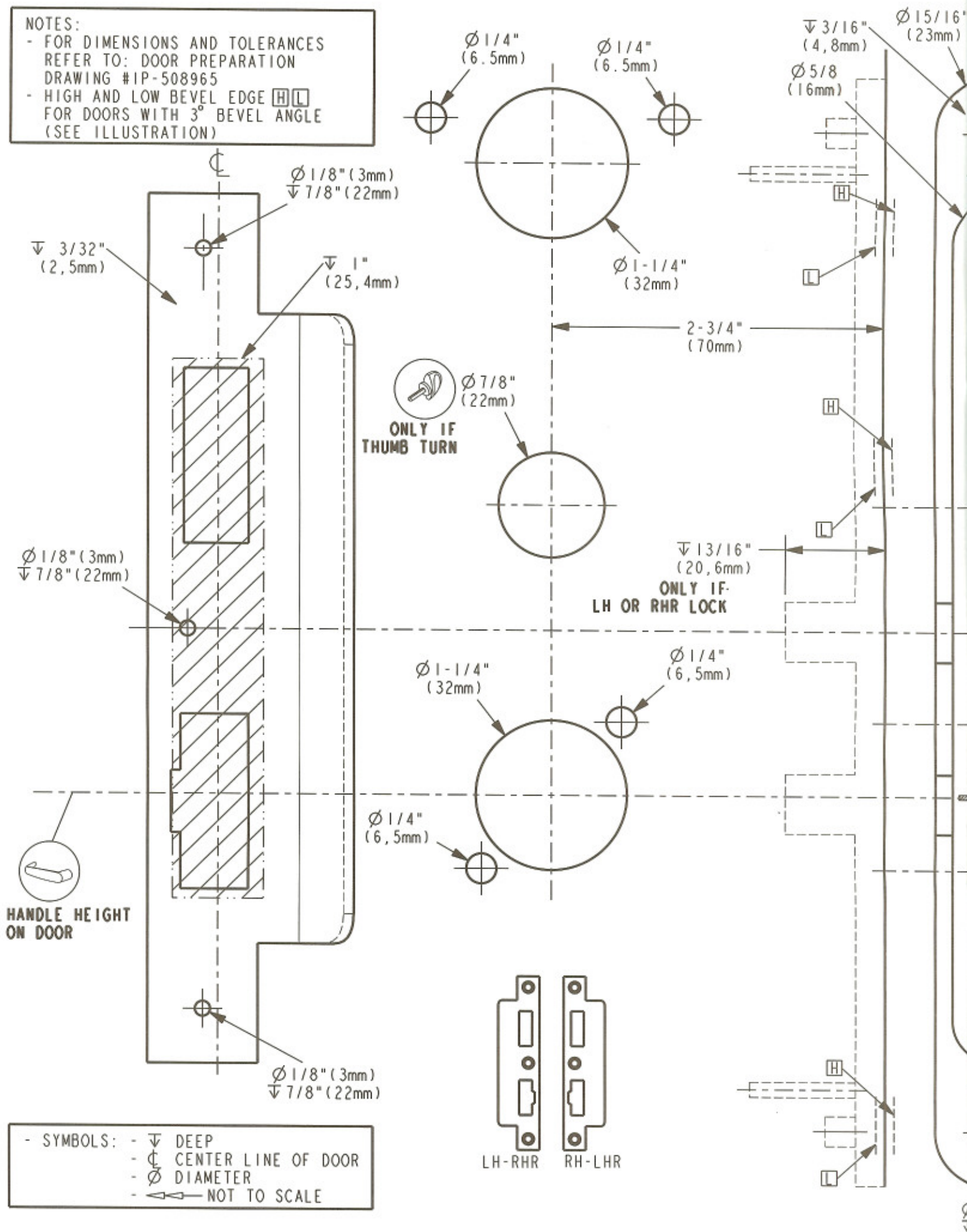

- SYMBOLS:**
- ∇ DEEP
 - C CENTER LINE OF DOOR
 - ϕ DIAMETER
 - \leftarrow NOT TO SCALE

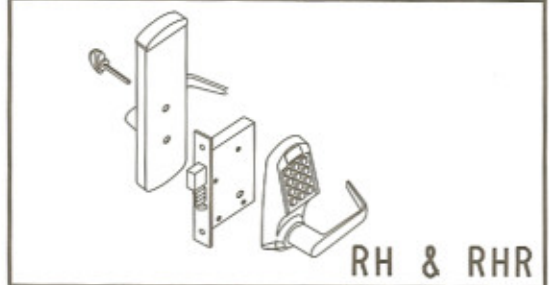
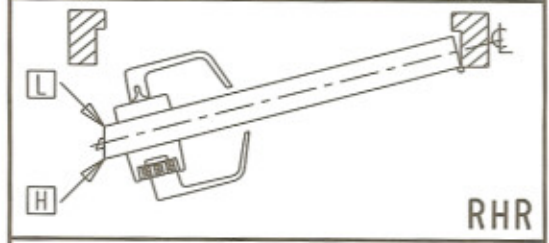
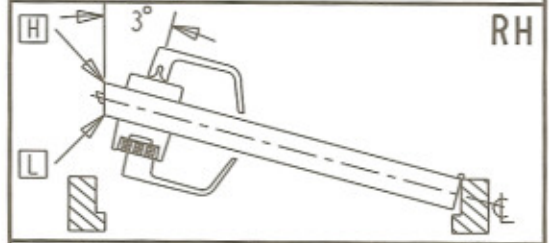
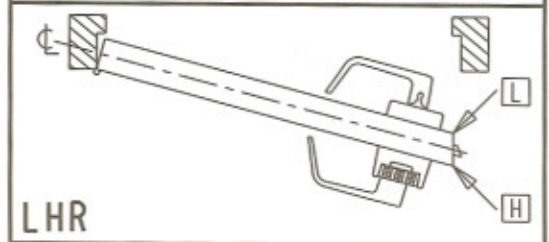
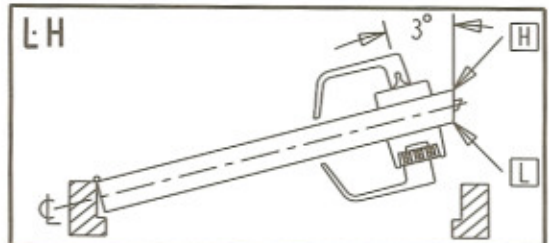
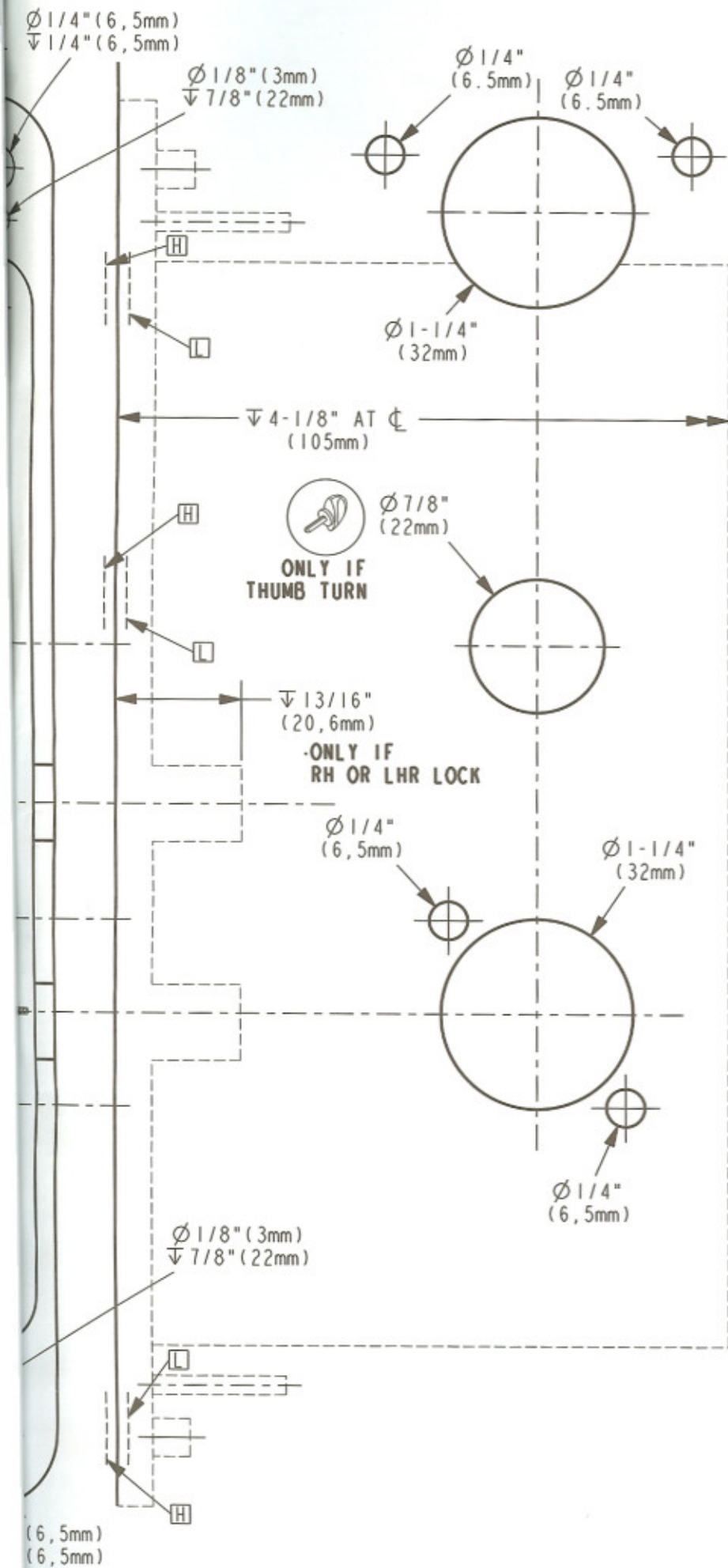

KABA
ilco

7301, Decarie Boul
 Montreal, QC Canada
 H4P 2G7
 www.kaba-ilco.com

DRILLING TEMPLATE
ORACODE 610, EPBL 4000
 EUROPEAN MORTISE - 23mm FRONT PLATE
 LEFT HAND (LH) - LEFT HAND REVERSE (LHR)
 RIGHT HAND (RH) - RIGHT HAND REVERSE (RHR)
 BACKSET OF: 70mm (2-3/4")

DT-508965	SHEET 1 OF 1	REV-3	ECN-10088
-----------	--------------	-------	-----------

NOTES:

- FOR DIMENSIONS AND TOLERANCES REFER TO: DOOR PREPARATION DRAWING #IP-509258
- HIGH AND LOW BEVEL EDGE \square \square FOR DOORS WITH 3° BEVEL ANGLE (SEE ILLUSTRATION)
- SYMBOLS: - ∇ DEEP
- $\text{---}\text{---}$ CENTER LINE OF DOOR
- \varnothing DIAMETER
- $\text{---}\text{---}$ NOT TO SCALE

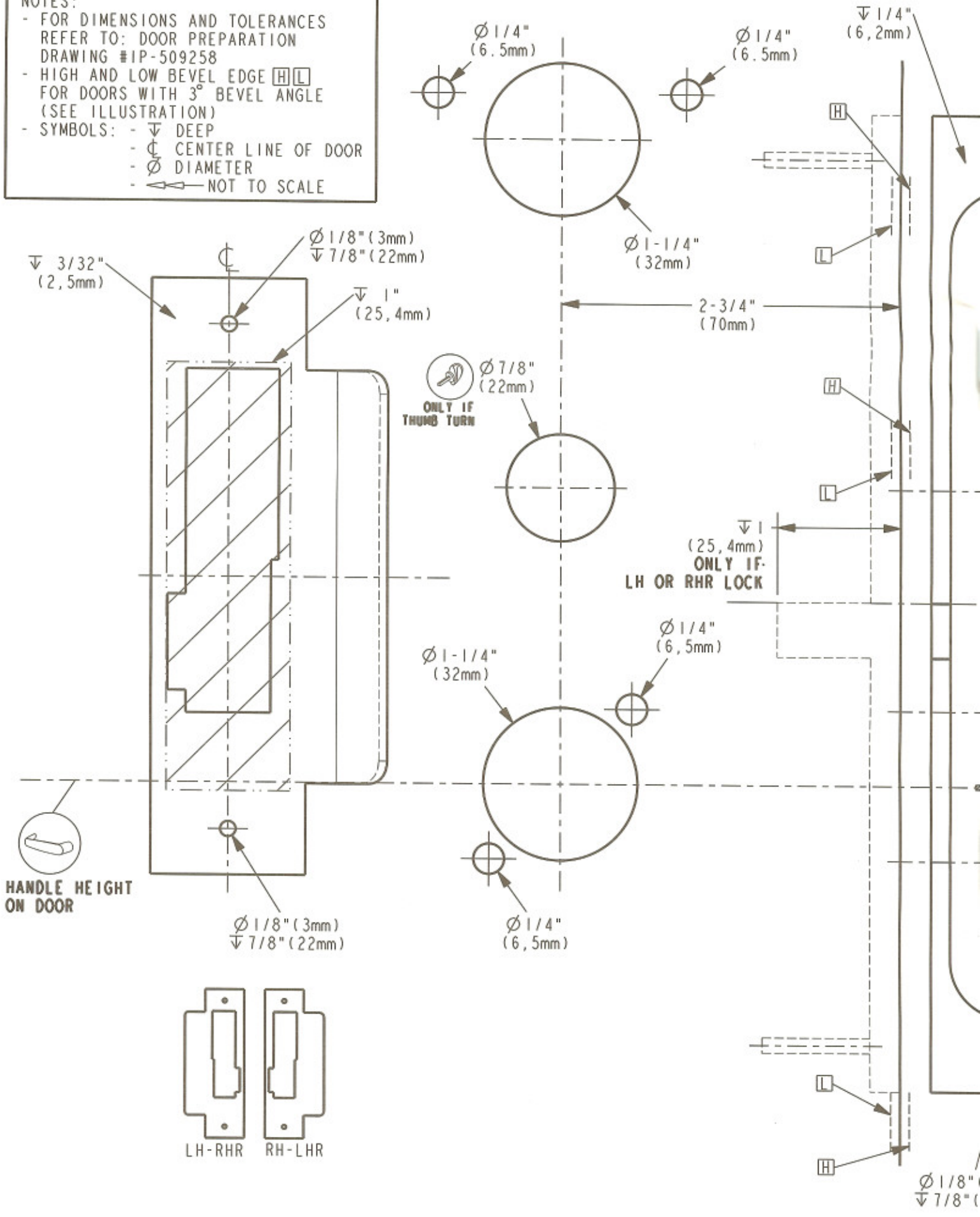

1.9 Using the Mechanical Key Override

The 4000 Series lock accommodates an interchangeable core (not included with the lock). For interchangeable cores, see your local dealer.

Important: The key override does not retract the latch and is not designed for constant use.

To operate the mechanical key override, perform the following steps:

- 1) Turn the key 90° in the same direction as the lever turns (as handed at the factory). **Do not turn the key and the lever at the same time. First, turn the key 90°, then turn the lever.**

Note: After changing the handing, the key will turn in the opposite direction that the lever turns.

- 2) Turn the lever and open the door while the key is still in the handle

Note: In the override mode, both levers turn at the same time.

- 3) Turn back the key and remove it from the lock.
- 4) To ensure that the override has been disengaged, turn the lever down. The latch should not retract.

1.10 Installing the ASA Strike

The bottom of the strike lip (A) (see Figure 13) must line up with the axis of rotation of the lever handle. Once the position of the strike has been established, follow the steps below:

- 1) Make the 1" (25 mm) cutout for the dust box according to the template. On prefabricated metal frames or when you are not installing the dust box, make sure the recess in the jamb is deep enough, over 1" (25 mm).
- 2) Place the dust box in the cutout.
- 3) Make sure you have the correct strike plate for the hand of your door - the larger and wider cutout, for the deadbolt, should be at the top and the long end of the plate should be at the bottom (see Figure 13).
- 4) Secure the strike plate with the two screws provided. If necessary, draw a line around the strike and use the line as a guide to cut out enough material to make the strike plate flush with the door frame.
- 5) In a proper installation, the auxiliary latch should rest against the strike plate between the bottom of the cutout and the bottom of the lip (B). If the strike was improperly installed, the auxiliary latch may slip into the strike hole and prevent the latch from locking securely.

Figure 13

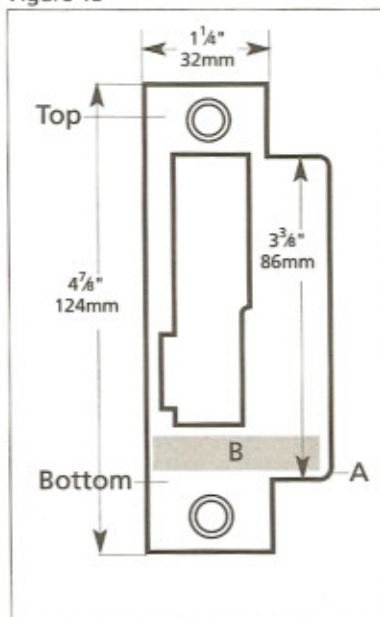

1.11 Testing the Operation of the Lock

Once the installation of the lock is complete, enter the factory-default service access code 4000. The lock should be tested for proper operation. **All testing procedures should be performed with the door open, unless otherwise specified.**

Inside Lever

- 1) Rotate the inside lever towards the floor. The latch bolt will fully retract if the lock is properly installed.

If the latch bolt does not retract check the hand setting of the latch hub drive on the inside housing, and its connection to the mortise.

If the lever does not rotate, the handing of the inside housing may be incorrect.

If the lever feels tight, the latch hub drive may be squeezed between the inside housing and the mortise. Check the position of the mortise in the door. It should be centered. If the mortise is centered, check to make sure the lock is the correct one for the thickness of the door.

Deadbolt (if applicable)

- 1) Project the deadbolt with the turn knob. The deadbolt should project fully, without any friction.
- 2) Retract the deadbolt with the turn knob. The deadbolt should retract fully, without any friction.
- 3) Project the deadbolt again. This time retract it by turning the inside lever. The deadbolt and the latch bolt should retract fully and simultaneously, smoothly and easily. Excess friction between the latch (or the deadbolt) and the strike may necessitate filing the strike (Refer to 1.2 of this section, Checking the Door).

Outside Lever

Depress the outside lever. The latch bolt should not retract. If it does, check the batteries and the position of the override cam on the inside housing.

If the lever feels tight or you are encountering some friction, the lock components may not be aligned correctly. Loosen the mounting screws and try to shift the outside housing until the friction is eliminated. If the problem persists, check the position of the holes in the door.

- 1) Once the lock is installed, enter the factory-default service access code 4000 using the metal pushbutton keypad. You will hear the sound of the motor engaging the clutch and see a green light behind the dark window flash for the unlock time period.
- 2) While the green light is flashing, depress the lever. The latch will retract to unlock.
- 3) When you release the lever, the motor winds back, the clutch is disengaged, and the mechanism relocks.
- 4) Repeat steps 1 to 3 several times to ensure the proper operation of the lock.
- 5) For mortise with deadbolt:
Project the deadbolt and repeat steps 1 to 3 several times. This time, both the latch and the deadbolt will retract fully and simultaneously.
- 6) Insert the override key into the lever handle and turn it 90° in the same direction that the lever turns, as handed at the factory. Then turn the outside lever (with the key still in the handle). **Do not turn the key and the lever at the same time (see 1-9).** The latch will retract. You will notice that in override mode both levers move at the same time. Perform this test several times, and then remove the override key.

Note: To ensure that the override has disengaged, depress the lever. The latch should not retract.

Important: for instructions on how to program the lock and change the factory-default Master and User codes, see the *4000 Lock Programmable Operations Manual*.

1.12 Changing the Hand

4000 Series locksets are handed at the factory, but can be changed as follows:

A. Change the settings of the outside housing assembly:

- 1) Remove the two Phillips flat-head screws (see A in Figure 14) from the front lock housing.
- 2) Remove the hex-socket flat-head screw (B) using a $\frac{3}{8}$ " (3 mm) Allen key.
- 3) Pull the attachment plate F apart from the front lock housing. (See Figure 15.)
- 4) Remove retaining ring G using ring pliers. (See Figures 16 and 17)
- 5) Remove the stop plate (see A in Figures 16 and 17) by sliding it up from the lever drive (B) using a flatblade screwdriver and a pair of needle-nosed pliers.
- 6) Remove the dowel pin (C) using a pair of needle-nosed pliers, and place it in the hole that corresponds to the desired hand, as shown in Figure 16 for left hand and Figure 17 for right hand.
- 7) Turn the outside lever 180° to the desired handing.
- 8) Remove and re-install the torsion spring (D) in the desired handing position as shown in Figure 16 for left hand and Figure 17 for right hand.
- 9) Re-install the stop plate (see (A) in Figures 16 and 17) onto the lever driver (B).
- 10) Re-install retaining ring G.
- 11) Re-install the attachment plate onto the front lock housing using the two Phillips flat-head screws (see (A) in Figure 14) and the hex-socket flat-head screw (B).

Figure 14

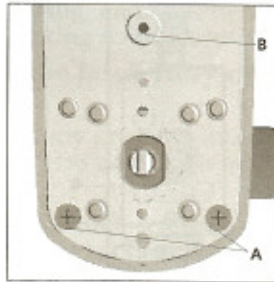

Figure 15

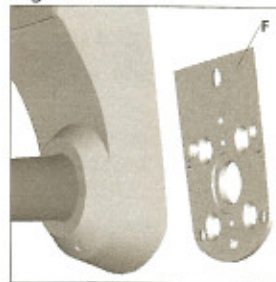

Figure 16

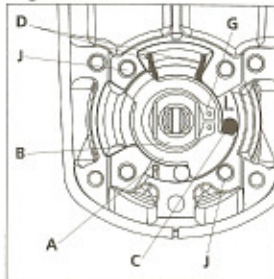
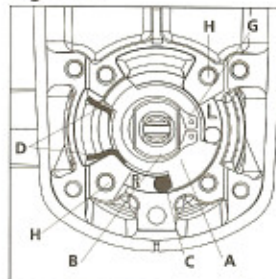

Figure 17



B. Change the settings of the inside housing assembly:

- 1) Remove the Phillips flat-head screw (see A in Figure 18) that secures the access plate to the front of the inside housing assembly, and then carefully lift and remove the plate (B).
- 2) Move the stop (C) to the position that corresponds to the desired handing, as shown in Figure 19 for left hand or Figure 20 for right hand.
- 3) Remove and re-install the torsion spring (A) in the desired handing position as shown in Figure 19 for left hand or Figure 20 for right hand.
- 4) Move the hand siding pin (B) to the position that corresponds to the desired handing as shown in Figure 19 for left hand or Figure 20 for right hand.
- 5) Replace the access plate (see B in Figure 18) and secure it with the Phillips flat-head screw (A).
- 6) Turn the drive disk (see A in Figure 21) on the back of the inside housing assembly to align the line mark (B) with the desired handing position right "R" or left "L", marked on the back plate as shown in Figure 21. Flats of override shaft (H) must be parallel with the vertical as shown in Figure 21.

1.13 Hard-wired Remote Unlock

All 4000 Series locksets have a hard-wired remote unlock capability. In order to use this capability, you will need the "Hard-wired Remote Unlock Kit," P/N: 062-507810. The instructions included with the kit describe how to install and use this function. For further details, contact your local dealer.

Figure 18

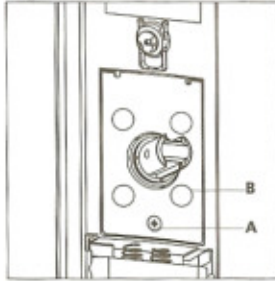

Figure 19

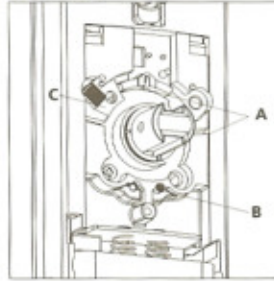

Figure 20

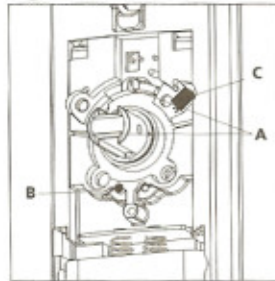
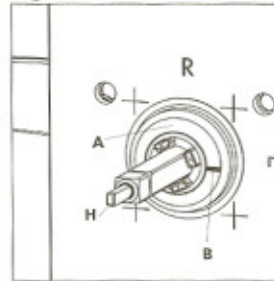





Figure 21



1.14 Troubleshooting

- ?** **When I depress the inside lever, why doesn't the latch retract?**
- ⇒ The four square prongs of the lever driver did not properly engage with the mortise drive unit.
 - ⇒ Remove the inside housing from the door and follow steps in section 1.8 "Installing the Lock."
- ?** **When I attempted to assemble the lock, why didn't the halves (front lock housing and inside housing) engage?**
- ⇒ The square spindle and override shaft and the mortise drive unit were not properly aligned.
 - ⇒ Ensure that the mechanical key override pins are vertical, and that the paint marks on the square spindle and the override shaft are lined up so that they face up—the override shaft is in a vertical position as shown in Figures 6 and 21.
- ?** **When I press the buttons on the keypad, why doesn't the lock work—no lights or beeps?**
- ⇒ The cable connector "F" (see Figure 10) is not inserted properly in the socket of inside housing assembly.
 - ⇒ Remove the lock from the door and firmly re-insert the connector in the socket.
- ?** **When a valid code is entered, the lock beeps and the green light flashes. Why doesn't the motor engage?**
- ⇒ The lock is in passage mode.
 - ⇒ For programming instructions, see "Lock Operating Instructions" in the *4000 Series Programmable Pushbutton Lock Operations Manual*.
- ?** **When I depress one of the levers, why do both the inside and the outside levers turn automatically?**
- ⇒ The mechanical key override is activated.
 - ⇒ Turn the override pins 90° in the direction opposite to the way the lever turns so that they are in a vertical position, and then install the interchangeable core.
- ?** **Why does the latch stick when the inside lever is depressed?**
- ⇒ Either the lock halves (inside and outside housing) are misaligned, the door was poorly prepared (hole drilling), or the mounting screws were overtightened.
 - ⇒ Remove the cover of the inside housing assembly. Loosen the four Phillips-head mounting screws by ½ a rotation. Check and adjust the alignment of the inside and outside housing, and then tighten the screws. If the problem persists, loosen the mounting screw closest to the latch bolt by 1/2 a rotation.
- ?** **Why doesn't the latch fully retract when the inside or outside lever is depressed?**
- ⇒ The door was poorly prepared (hole drilling), the back set is too big or too small, or the beveled door angle was not considered when the door was marked for drilling.
 - ⇒ Slightly loosen the latch screws and depress the lever to check the retraction. Remove the lock and adjust the holes.

	= Symptom/problem
	= Síntoma/problema
	= Problème
	= Possible cause
	= Causa posible
	= Cause possible
	= Remedy
	= Solución
	= Solution

**U.S.A.
and International:**

ILCO UNICAN CORP.

UNICAN Lock Division

2941 Indiana Avenue, Winston Salem, NC 27105, U.S.A.

Tel.: 800 849 8324 / (336) 725 1331

Fax: (336) 722 8814

E-Mail: info@win.ilcounican.com

Canada: **ILCO UNICAN INC.**

7301 Decarie Boulevard, Montreal, Qc H4P 2G7 Canada

Tel.: 888 217 5654

Fax: 888 217 5657

E-Mail: info@ilcounican.com

www.ilcounican.com

