

HSW-ISO Installation Instructions

Track rail 72 x 75 mm

1. Ceiling substructure for track rail and installation of the track rail:

The track rail must be bolted over its entire length (including the stacking track area) to a correctly aligned, horizontal (longitudinally and transversely) substructure (e.g. DORMA substructure system). The substructure should be designed to accommodate the total weight of all the panels both in the stacking area and in the partition section.

The fixing point intervals for mounting the track rail to the substructure should be approx. 300 mm along the straight sections and approx. 100 mm in the stacking area.

Caution: All the track joints must be provided with connection pins (a) in order to ensure a flush transition between the track sections and thus smooth sliding panel operation. **(Fig. 1)**

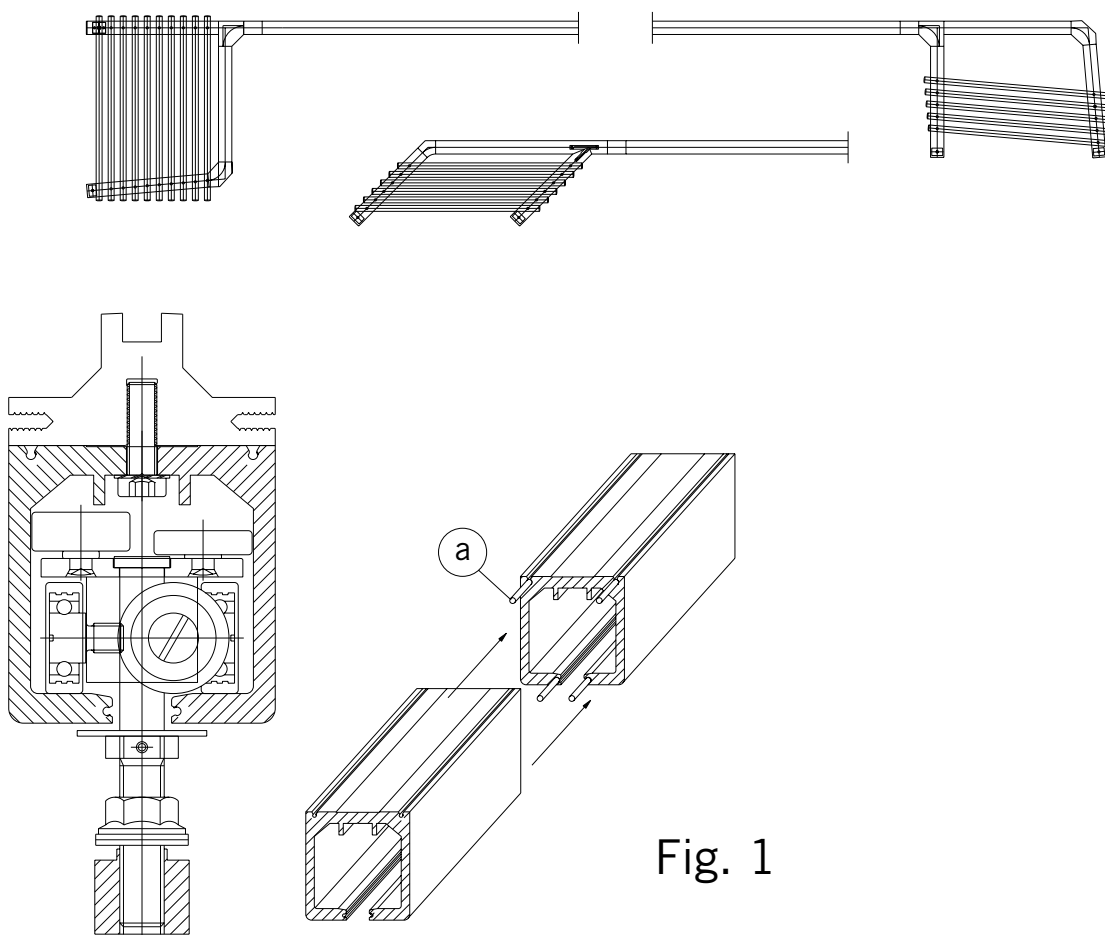

Fig. 1

2. Preparing the floor (Fig. 2):

The floor must be smooth and continuous to ensure full-facial contact with the bottom seal. A lip should also be provided to repel driving wet.

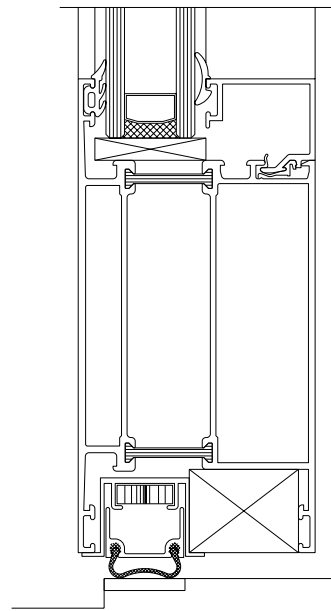

Fig. 2

3. Glazing:

The aluminium frame is supplied ready assembled and surface treated.

In performing the glazing work, ensure compliance with the instructions and guidelines of the double glazing manufacturer and especially the padding instructions for fitting the sealed units in the frames.

4. Installing the sliding panels:

Slide the complete panel with track rollers into the track in accordance with the required panel sequence and guide roller arrangement (**Fig. 3**) through the gap filled by the maintenance end piece.

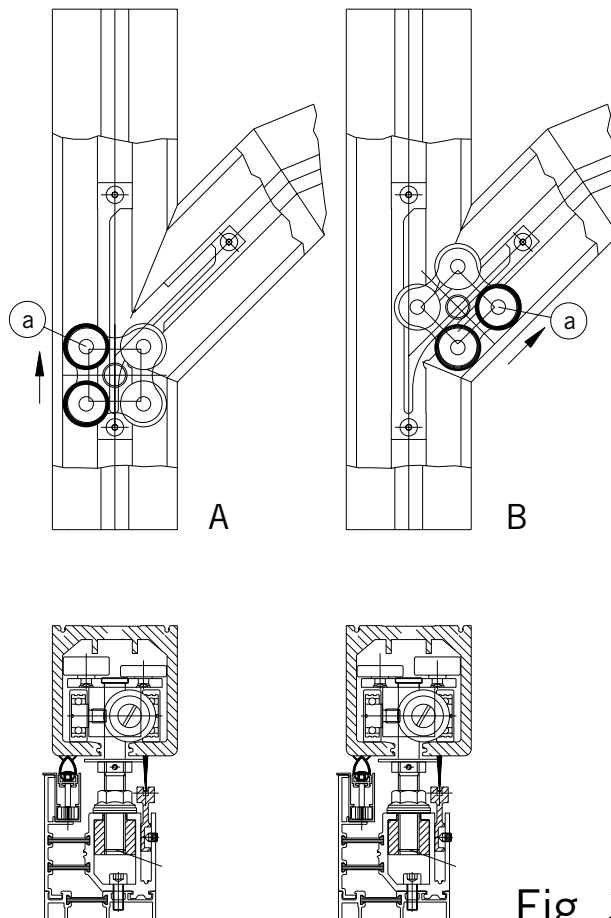

Fig. 3

4.1 Aligning the panel height (Fig. 4):

The height of the panels must be aligned to create an 8 mm clearance between the floor and the bottom door rail with the partition closed.

Ensure that the top clearance is $33 \text{ mm} \pm 5$.

To adjust the height of the panels, loosen nut (b) and adjust the height via nut (a) (using a 17 mm open-jaw wrench).

Caution!

The set screw (c) must be loosened prior to adjustment as otherwise the pin in nut (a) will shear off.

Counter-clockwise rotation = more floor clearance

Clockwise rotation = less floor clearance

4.2 Aligning the carrier clearances:

Slightly tighten nut (b), bring the panel into the stacking area, loosen nut (b) and set screw (c) and align the panel in the stacking area. Re-tighten nut (b) and lock with M10 set screw (using 5 mm Allan key). Nut (a) can only be used to adjust the height.

If additional height or lateral alignment is necessary, proceed as follows:

Loosen M5 set screws at top brush profile (use 2.5 mm Allan key) and then remove profile with brush seal.

Loosen M10 set screw (c) with 5 mm Allan key, adjust nuts (a) and (b) and then retighten. Tighten M10 set screw and insert top brush profile. Align profile and secure with M5 set screws.

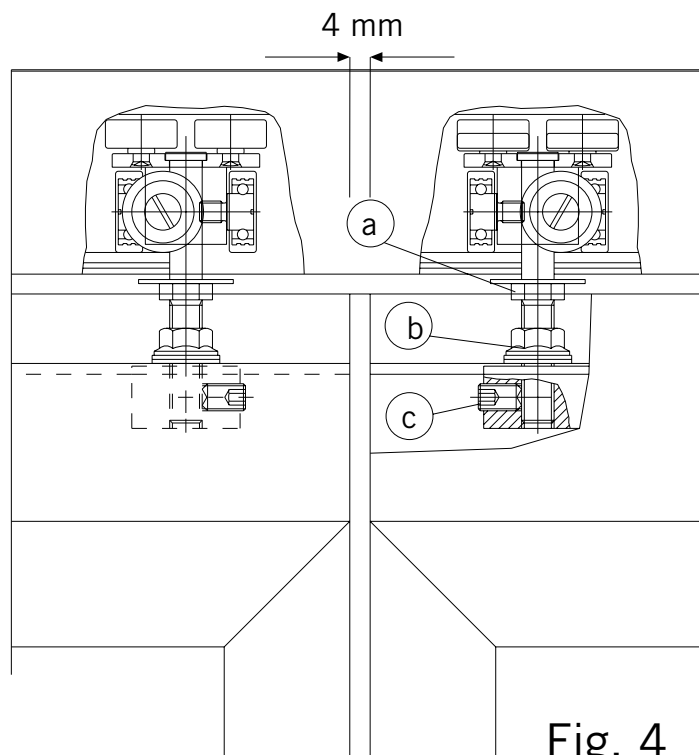

Fig. 4

5. Single and double action pivoting sliding panels (Fig. 5):

Sequence of operations:

5.1 Switching from pivoting to sliding action

- A Screw collar bolt fully into the middle section of the lock mechanism
- B Unlock front door holder
- C Unscrew top locking bolt from the top section of the lock mechanism

5.2 Switching from sliding to pivoting

- C Screw top locking bolt fully into the upper section of the lock mechanism
- B Engage front door holder in strike plate
- A Undo collar bolt

Caution!

During these functional changeover operations, ensure compliance with the given sequence of operations and in particular never undo both top bolts. If this should accidentally occur, the panel will sink onto the floor. It must then be raised and re-secured with one of the two bolts.

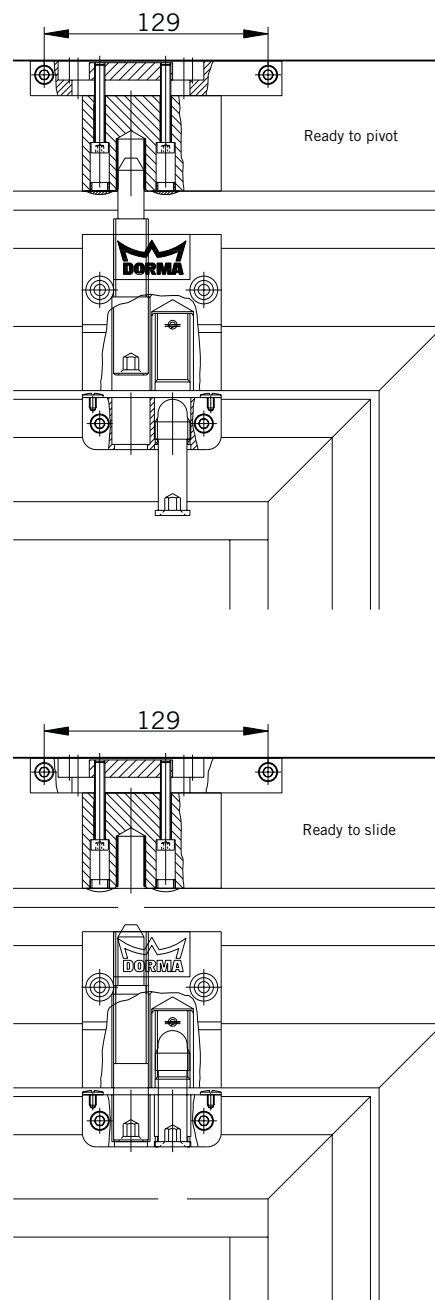

Fig. 5

6. Installing the single action door panel (Fig. 6)

With the system fully aligned, the single action door panel should be fixed to the wall via the wall connection post so that it is perfectly vertical and straight.

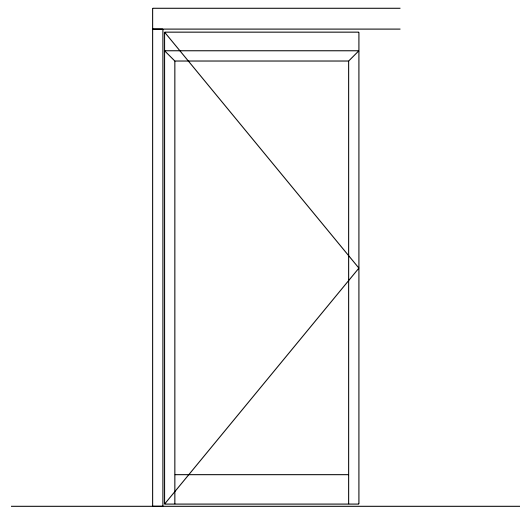

Fig. 6

7. Replacing the track rollers:

The maintenance end piece (b) can be removed for the replacement of defective rollers. For this purpose, the pins in the track channel need to be pushed back (using for example a flat tipped screwdriver); the screw must then be loosened and the maintenance end piece can then be withdrawn. When re-installing the maintenance end piece, insert it back into the track run (1), screw fix and then push the pins (2) back across the joint in order to secure the track surfaces and ensure that they are flush (Fig. 7).

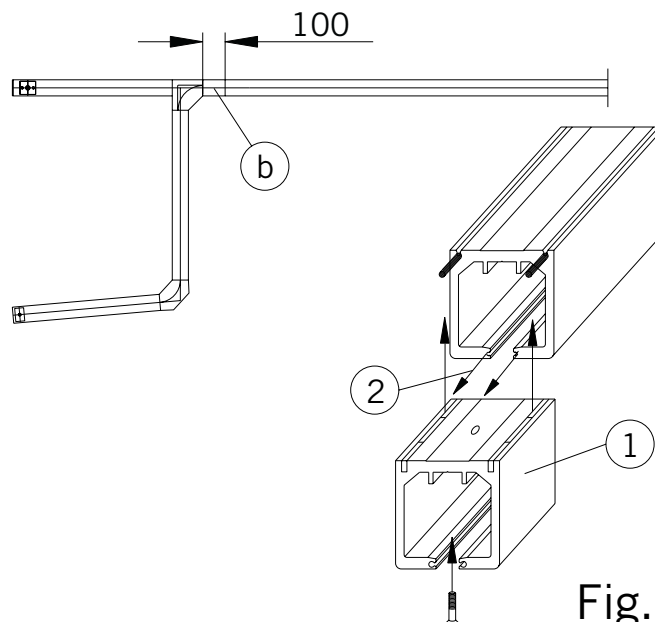

Fig. 7

8. Track roller arrangement:

There are four roller arrangements available (Fig. 8)

T arrangement:

Tandem roller for all automatic-entry stacking tracks.

TN arrangement:

Low-height tandem roller arrangement (with four reduced-height guide rollers) for reshuffle module and niche-type parking/stacking systems.

K arrangement:

Cross-over roller for all situations involving T and L track fittings.

KU arrangement:

Cross-over roller arrangement with 90° deflection aid.

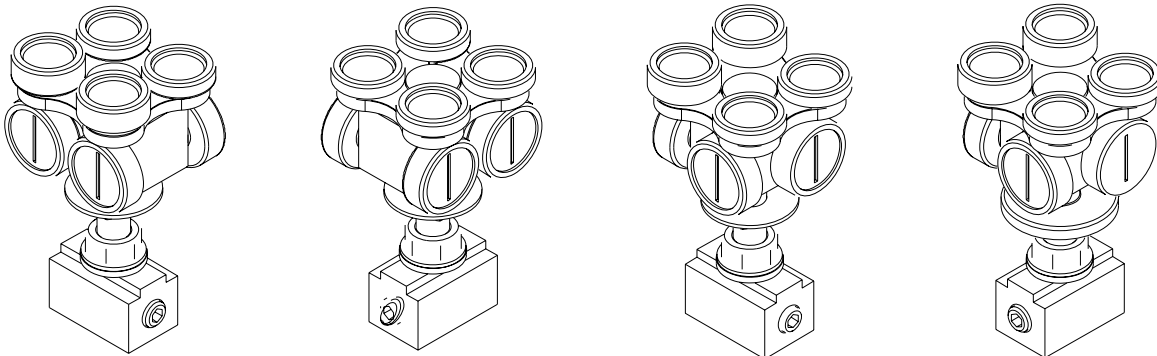

Fig. 8

T-type roller arrangement

TN-type roller arrang.

K-type roller arrang.

KU-type roller arrang.

The arrangement of the track rollers is critical in the diversion area (Fig. 9)

A Roller block for straight-through section = high guide rollers (a) outside

B Roller block for entry into branch section = high guide rollers (a) inside

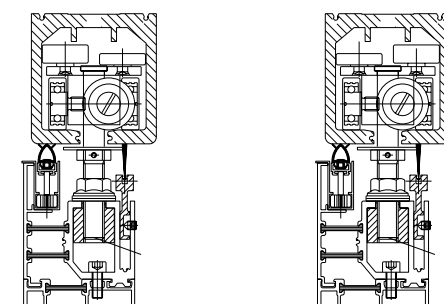
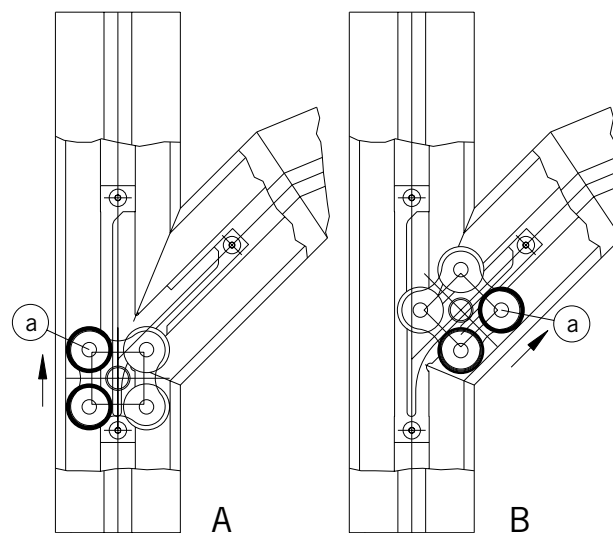

Fig. 9

9. Bottom lock (Fig. 10):

Position the panel by moving it into its end position and then ensuring that it is properly aligned. Slide the drilling template provided under the lock module and extend the locking pin so that the centre bore can be aligned to its location. Check the position once again and then secure the drilling template (e.g. by holding firmly in position by hand or foot). Retract the locking pin and move the panel away.

The position of the eccentric bushing or strike plate can then be properly marked through the drilling template and then the holes can be drilled (**see dimensions, Fig. 11**).

Mount the strike plate / eccentric socket as appropriate. (For exact positioning, strike plate and keep can be adjusted ± 4 mm and ± 2.5 mm respectively). Then bring the panel into position and lock.

Now bring the next panel into position (leaving a clearance of 4 mm) (**Fig. 12**).

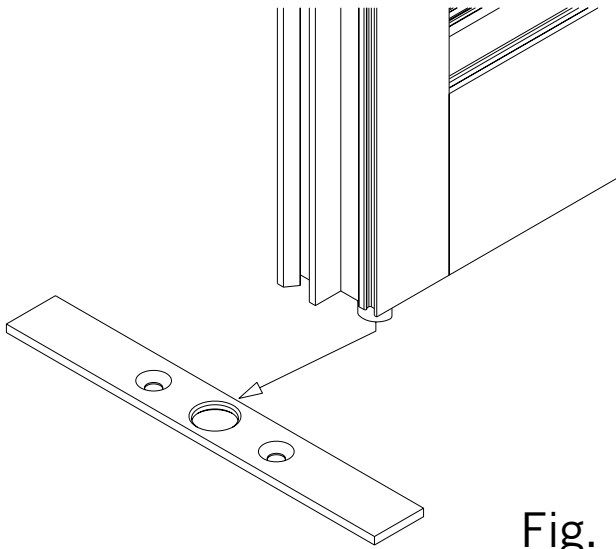

Fig. 10

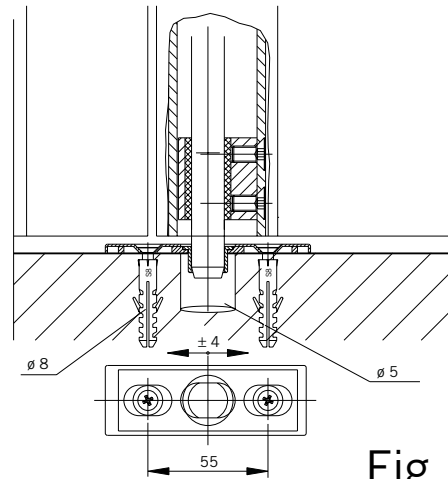

Fig. 11

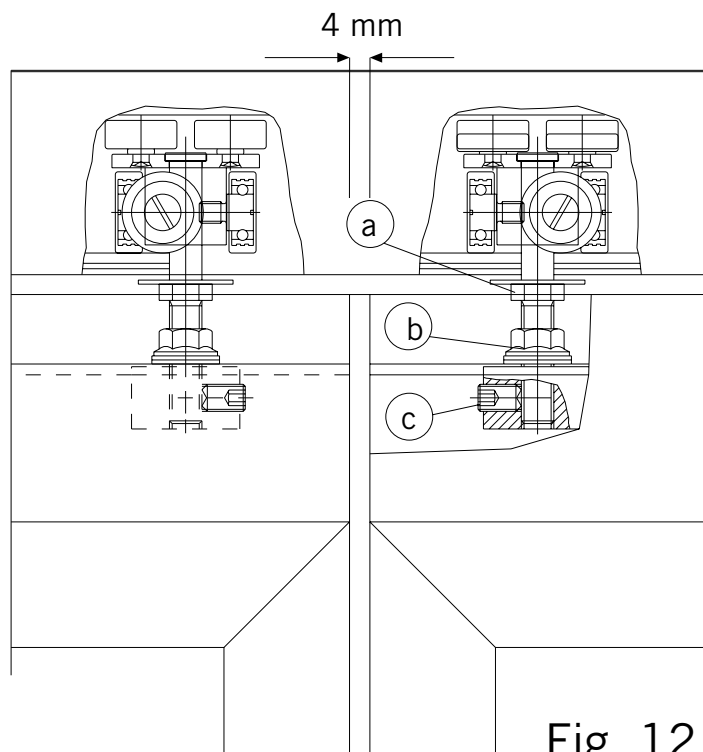

Fig. 12

10. Preparing the floor:

- A** In the standard design, eccentric sockets are used as the lock keeps.
Drill hole 25 mm dia. 30 mm deep for eccentric sockets, plus 8 mm dia. hole for anchor plug. Align eccentric socket (double eccentric) and tighten with centre screw.
- B** Eccentric socket inserted in recessed channel section (**Fig. 13**)

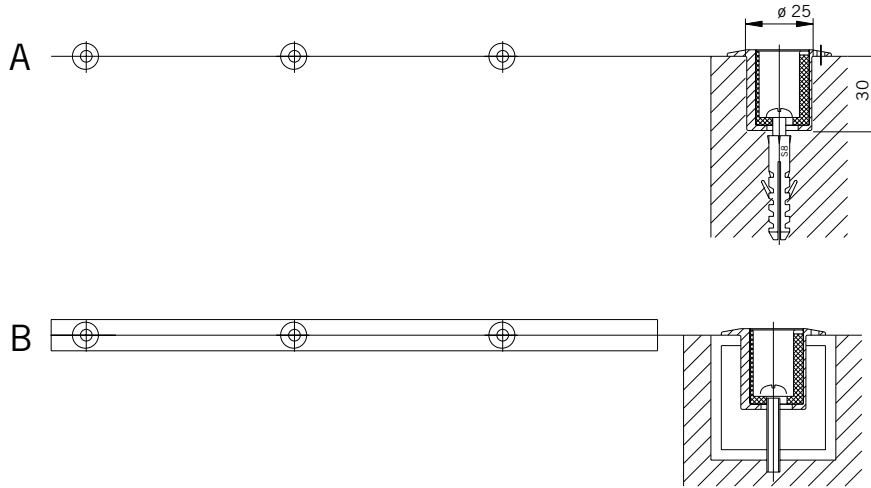

Fig. 13

10.1 Installing eccentric sockets (Fig. 14):

Adjustable eccentric sockets (standard system) with plastic inner sleeve for all door holders, floor locks and bearing assemblies:

Drill hole 25 mm dia., at least 30 mm deep, and 65 mm (for door holders) or 98.5 mm (for deadlocks) from the outside edge of the panel.

In addition, drill 8 mm dia. hole at the centre for anchor plug.

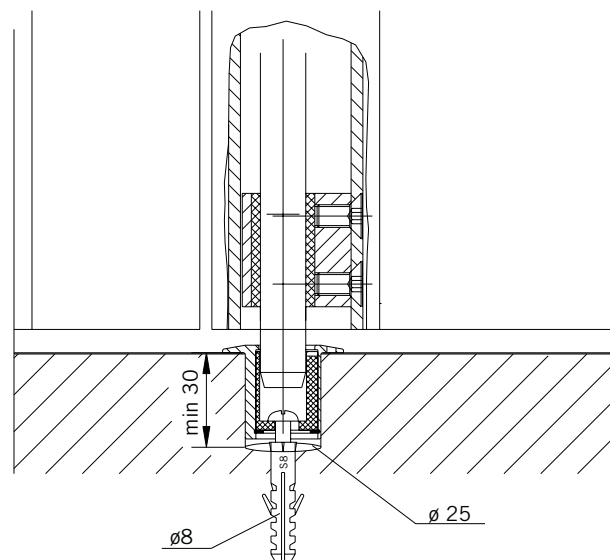

Fig. 14

10.2 Installing strike plates (Fig. 15):

Adjustable strike plate for single action and double action pivoting sliding panels with plastic bushing for the bearing assembly:

Drill 25 mm dia. hole for strike plate at least 15 mm deep, and 65 mm (for door holders) or 98.5 mm (for deadlocks) from the outside edge of the panel. In addition, drill 8 mm dia. hole for 8 mm anchor plug.

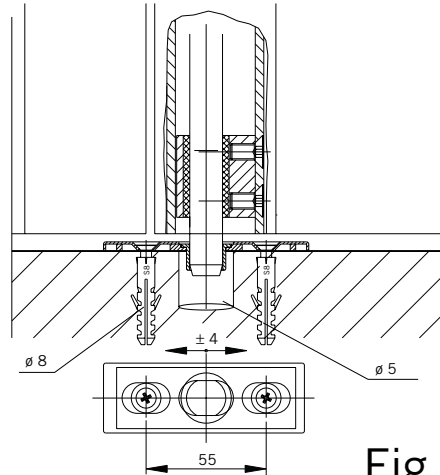

Fig. 15

11. Top brush seal (Fig. 16):

The top brush can be adjusted if necessary.

If additional height or lateral alignment is necessary, proceed as follows:

Loosen M5 set screws at top brush profile (use 2.5 mm Allan key) and then adjust and re-fix profile with brush seal.

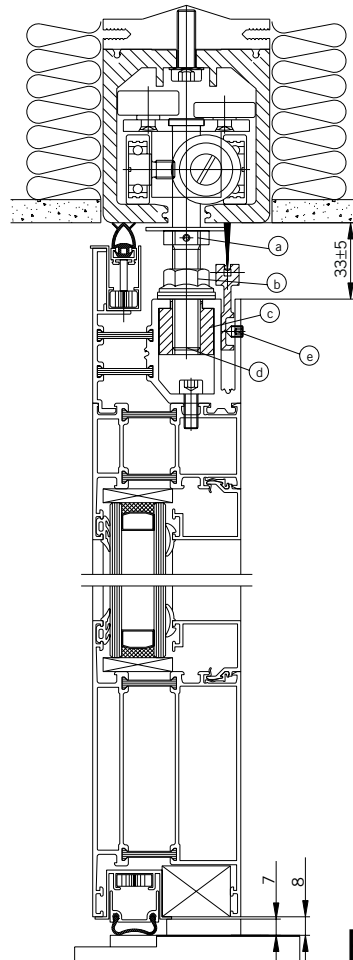

Fig. 16

12. Sliding the panels (Fig. 17):

When closing the sliding partition, always lock each panel into position before moving the next one along. The panels are very easy to move and should not require any force. Always slide the panel along with one hand to ensure ease of movement. Either slide or pull.
In the stacking area, bring the panel into position at a slight angle.

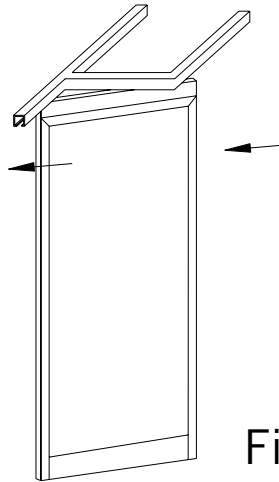

Fig. 17

13. Seals (Fig. 18):

Adjustment of the ATHMER seals commences at the last panel. Remove the release wedge and gradually unwind until the seal is just in contact with the floor surface or track rail. Take care to avoid damage by working in this gradual fashion.

Apply paper test to check for correct contact: Place a sheet of paper between the panel and the floor surface/track rail with the ATHMER seal in its released position. Extend seal. The contact pressure should be just enough to hold the paper secure but still allow it to be withdrawn with a small degree of effort.

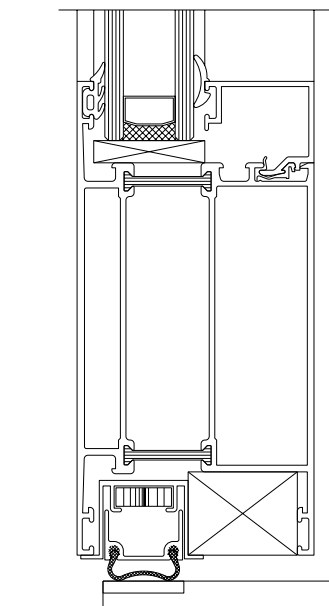

Fig. 18

14. Maintenance:

In order to ensure functional reliability over the long term, please comply with the following instructions:

- Ensure that locks and floor bolts are kept in good working order
- Regularly clean sockets/keeps for locks and bolts located in the floor