



**FOR FAIL SECURE CENTERLINE CYLINDRICAL LOCKSETS
(FIRE RATED AND NON-FIRE RATED)**

Important

- When installing these fail secure models, the local Authority Having Jurisdiction shall be consulted with regards to the use of listed hardware to ensure emergency exit from the secured area.
- Installations of this strike, qualify as “Indoor Use Only”, when not continuously exposed to an outdoor environment. For perimeter doors, use of a latchguard is recommended.
- Not all ANSI-prepped frames are manufactured alike. Some modifications may be required in the field.

UL294 Performance Ratings

Access Control Line Security: Level 1
Destructive Attack: Level 1
Endurance: Level IV
Standby Power: Level 1

Dimensional Details

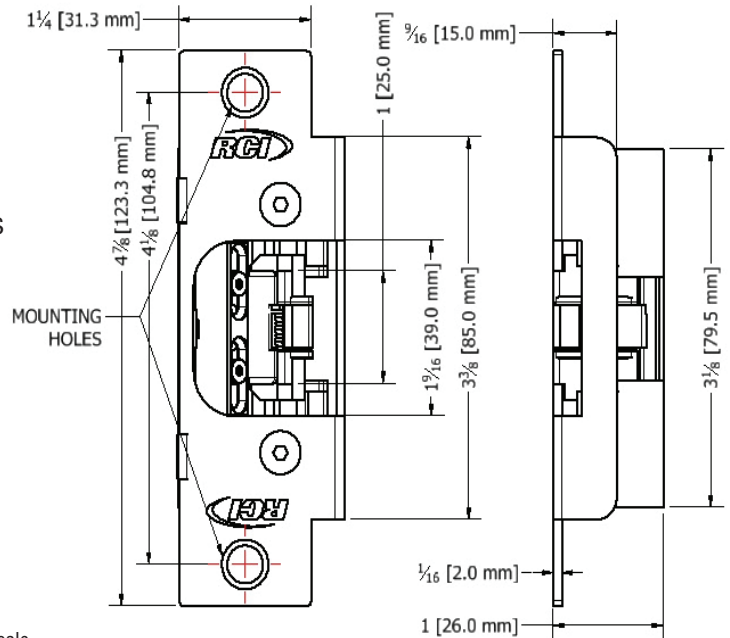

NOTE: Not to scale.
Specifications are subject to change without notice.

Faceplate & Extras Security options

- ANSI 14 and ANSI 04 faceplate options are available
- Separate SECURHK9 accessory kit available with security TORX screws and bit.

Frame Considerations

These strikes are designed for most frames with the 4-7/8 x 1-1/4” ANSI cutout. If the dust box is less than 1” deep, it has to be removed. If removal of the dustbox is required, it is necessary that the mounting tabs be maintained.

Ensure that the frame cutout on the front face of the frame is 1/4” deep. This is important for smooth latch exit. If not see the point 6 Keeper Extension on page 2.

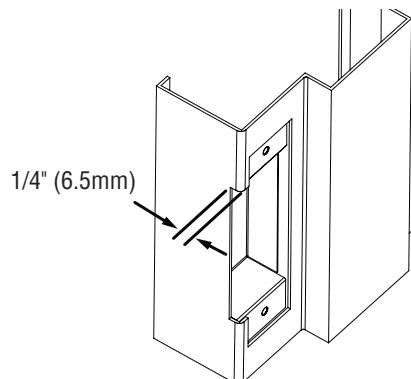

Strike Installation Instruction for Typical Fail Locked Application

1. Drill minimum 1/2" diameter wire access hole to suit handing of the door and allow for wire harness. LM units will require another wire access hole for LM wires.

2. Use the appropriate wire harness supplied.

12V for 12VDC & 12-24VAC

24V for 24VDC only.

Attach the red wire to (+) positive of the power supply.

Attach the black wire to the power supply (-) negative.

If using AC power, polarity is not observed.

To meet BHMA A156.31, install the MOV provided across the positive and negative wires or terminals of the harness. The MOV is not polarity sensitive.

Note: LM units are not BHMA qualified.

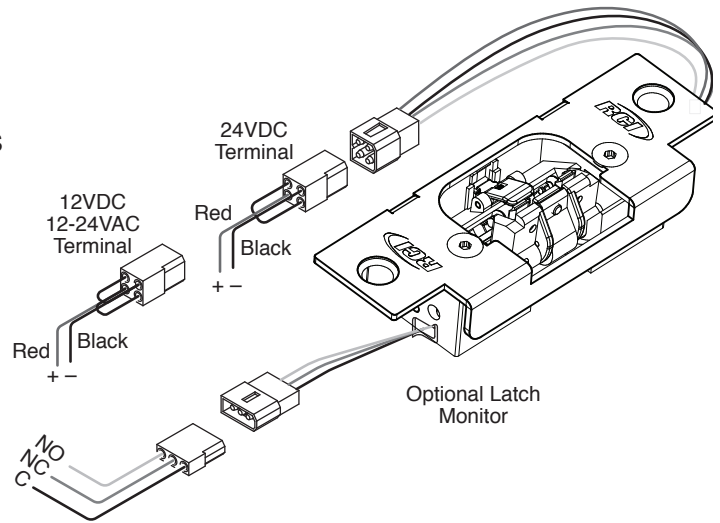

NOTE: Overheated or burnt coils caused by incorrect input voltage/wire harness combinations will not be covered under warranty.

Voltage must not exceed $\pm 10\%$ of rated voltage.

DC Direct current, continuous duty = energized 1 minute or more
AC Alternating current, intermittent duty = energized less than 1 minute with duty ratio 1:5

Electrical Latch Monitor (LM) Specification:

SPDT switch, 0.1A 30VDC, resistive load

Note: Contacts identified on the harness sleeve are indicated with the keeper in a closed and locked condition, with no latch present.

Latch Monitor Wires (door open no latch)

Black = Common (C)

Blue = Normally Closed (NC)

Orange = Normally Open (NO)

3. Mount the electric strike with the 12-24 x 3/8" screws. Depending on the thread engagement into the mounting tabs, shims (square shims with two holes supplied) may be required behind the faceplate to secure the strike.

4. The keeper of the strike allows +/- 1/4" of vertical adjustment on the latch center.

The deadlatch should be aligned with the centerline of the keeper.

Loosen the 2 hex drive screws on the keeper to make the vertical adjustment and re-tighten to secure the new position.

Do not overtighten.

Ensure that there is some keeper play in the locked state.

Use thread locking compound for secure bonding of the screws.

5. The provided 1/16" shims (two rectangular & one little square shim) can be added onto the keeper to minimize the gap between keeper and latch in the door open/close direction (horizontal adjustment). Secure shims using M3 Phillips screws provided.

6. If the frame cutout is less than 1/4" or when the latch does not smoothly exit the cavity, attach the Keeper Extension onto the keeper as shown.

4. Vertical Adjustment

KEEPER ADJUSTMENT SCREWS

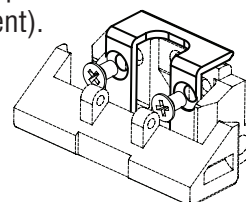
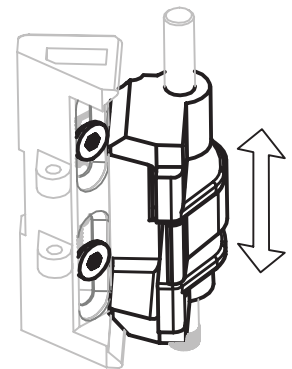
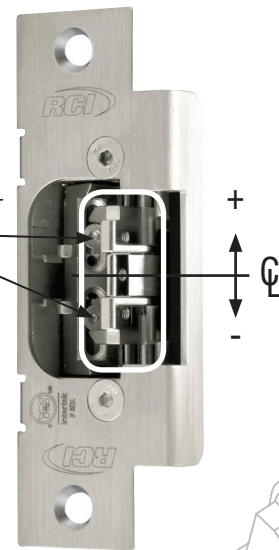

6. Keeper Extension

5. Horizontal Adjustment