



PORTEO

Product information
Assembly instruction

Follow the instructions!

D	GB	F
NL	I	E

“Translation of the original documentation”

Contents

General information

CE declaration of conformity	page 4
CE declaration of incorporation	page 5

1. For your safety	page 6 – 9
2. Standard scope of delivery	page 10
3. Status on delivery and assistance when it comes to selecting appropriate accessories	page 11

Assembly instruction

4. “Door basics” technical terms	page 12
5. Function and adjustments	page 13
General information	
Function	
Settings/Adjustments	

6. Approach to installation and commissioning	page 14
--	---------

Determine way of mounting, then mount system and commission PORTEO door assistant

Lintel mounting with slide channel

– Lintel mounting on the hinge side (pull-side), left-handed version	Installation drawings A
– Lintel mounting on the hinge side (pull-side), right-handed version	Installation drawings B
– Lintel mounting on the opposite hinge side (push-side), right-handed version	Installation drawings C
– Lintel mounting on the opposite hinge side (push-side), left-handed version	Installation drawings D

Door leaf mounting with slide channel

– Door leaf mounting on the hinge side (pull-side), left-handed version	Installation drawings E
– Door leaf mounting on the hinge side (pull-side), right-handed version	Installation drawings F
– Door leaf mounting on the opposite hinge side (push-side), left-handed version	Installation drawings G
– Door leaf mounting on the opposite hinge side (push-side), right-handed version	Installation drawings H

Option – Lintel mounting with standard/projecting arm

– Lintel mounting on the opposite hinge side (push-side), left-handed version	Installation drawings I
– Lintel mounting on the opposite hinge side (push-side), right-handed version	Installation drawings J

7. Requirements for standard commissioning	page 15
8. Standard commissioning	page 16 – 17
9. Extended commissioning	page 18 – 21
10. Operation	page 22 – 23
Power switch	
Program switch -adjustment of operating types/functions	
– Operating type OFF	
– Operating type PowerMotion	
– Operating type PermanentOpen	
PermanentOpen with flip-flop function (pushbutton -optional)	
– Operating type/function PowerLess	
– Operating type/function Push&Go	
– Obstacle recognition	
– Vandalism mode	
– Latching action	
– Locking recognition	
11. Adjustments	page 24 – 25
Adjustment of operating type PowerLess	
Adjustment of speed	
Adjustment of hold-open time	
Adjustment of wall blanking (optional, only with Comfort Board)	
Adjustment of delayed opening for locking device via DIP switch and potentiometer	
Adjustment for application of an electric strike (optional)	
Adjustment of latching action	
12. Connection diagram accessories	page 26
13. Connection diagram: electric strike	page 27
14. Direct power supply, straight out of the wall	page 28
15. Accessories	page 29 – 30
16. Hand-held transmitter DORMA atent	page 31 – 32
17. Commissioning, care, maintenance	page 33
18. Troubleshooting instructions	page 34 – 35

PORTEO

EC Declaration of conformity

en EC DECLARATION OF CONFORMITY
The undersigned representing the following manufacturer DORMA GmbH + Co. KG DORMA Platz 1 58256 Ennepetal Germany
declares that the product PORTEO
complies with the provisions of the EC Directive(s) specified in the Appendix and that the standards and/or technical specifications referred to in the Appendix were applied.

Ennepetal, 18.10.2011

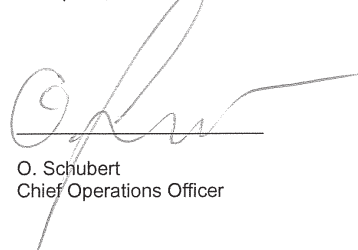

O. Schubert
Chief Operations Officer



Anlage / Attachment / Annexe: 18.10.2011 SU

Richtlinie / Directive

<input checked="" type="checkbox"/>	2006/95/EG	Niederspannungsrichtlinie / Low Voltage Directive / Directive basse tension
	89/106/EWG/EEC/CEE	Bauprodukte / Building products / Produits de construction
<input checked="" type="checkbox"/>	2004/108/EG	Elektromagnetische Verträglichkeit / Electromagnetic compatibility / Compatibilité électromagnétique
	2006/42/EG	Maschinenrichtlinie / Machinery directive / Directive machine <small>Die technischen Unterlagen sind erhältlich beim Manager Productcompliance unter: / The technical documentation is available from the Product Compliance Manager at: / Les documents techniques sont disponibles auprès du Manager conformité produit à l'adresse suivante: product.compliance@dorma.com</small>

Harmonisierte europäische Norm, nationale Regel / Harmonized European standard, national rule / Norme européenne harmonisée, disposition nationale:

<input checked="" type="checkbox"/>	EN 13849-1	<input checked="" type="checkbox"/>	EN 61000 - 3 - 2	EN 179
	EN ISO 12100	<input checked="" type="checkbox"/>	EN 61000 - 3 - 3	EN 1125
<input checked="" type="checkbox"/>	EN ISO 12100-1		EN 55014	EN 1154
<input checked="" type="checkbox"/>	EN ISO 14121-1	<input checked="" type="checkbox"/>	EN 55022	EN 1155
<input checked="" type="checkbox"/>	BGR 232	<input checked="" type="checkbox"/>	EN 60335 - 1	EN 1158
<input checked="" type="checkbox"/>	EN 61000 - 6 - 2		EN 60950 - 1	EN 1935
<input checked="" type="checkbox"/>	EN 61000 - 6 - 3			EN 12209

Andere in Bezug genommene Dokumente oder Informationen, die von den anzuwendenden EG-Richtlinien, Normen und technischen Spezifikationen gefordert werden. / Other references or information required by the applicable EC directive(s), standards and technical specification. / Autres références ou information demandées par la (les) directive(s) CE d'application et que les normes et spécifications techniques:

--

PORTEO

EC Declaration of incorporation

en EC Declaration of Incorporation
The manufacturer DORMA GmbH + Co. KG DORMA Platz 1 58256 Ennepetal Germany
declares that the incomplete machine PORTEO
complies with the following basic requirements of the Machinery Directive (2006/42/EC) - Annex I, Section: 1.1.3, 1.1.5, 1.2.1, 1.2.3, 1.2.5, 1.2.6, 1.3.1, 1.3.2, 1.3.3, 1.3.4, 1.3.7, 1.3.8.1, 1.3.9, 1.5.1, 1.5.2, 1.5.4- 1.5.10, 1.5.16, 1.6.1, 1.6.2, 1.6.3, 1.6.4, 1.7.1.1, 1.7.3, 1.7.4
The incomplete machine further complies with all relevant provisions of Directives 2006/95/EC and 2004/108/EC. It may be incorporated and operated in automatic door control mechanisms in conformity with the Machinery Directive provided that the manufacturer of the systems ensures that all requirements under the Machinery Directive are met and an EC Declaration of Conformity has been issued. The specific technical documentation was prepared and is available from the Product Compliance Manager at product.compliance@dorma.com . It will be electronically forwarded to individual public authorities in response to a duly reasoned request.

Ennepetal, 18.10.2011

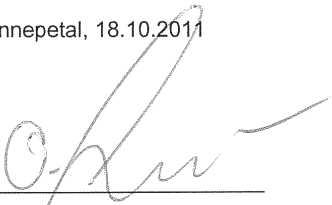

O. Schubert
Chief Operations Officer

PORTEO

1. For your safety

This documentation contains important information regarding the mounting and the safe operation of the door system. Please read these instructions carefully before using the **PORTEO**.



It is important for your personal safety to abide by all enclosed instructions.

Installation performed incorrectly may cause serious injury.

Using control elements, making adjustments or performing procedures that are not described in this documentation may cause electric shock, danger caused by electric voltage/current and/or danger due to mechanical incidents.

Please keep these documents for further reference and hand them over to the person in charge in case the system is transferred to another party.

Explanation of symbols

-  **NOTE** This symbol underlines important information that may facilitate your work.
-  **REMARK** This symbol warns you of possible system damage and explains how to avoid this damage.
-  **WARNING** This symbol indicates dangers that may cause material damage or result in personal injury or death.

Intended application

As an electromechanical operator, the **PORTEO** is only designed to open and close interior swing doors with an admissible door-leaf weight up to 140 kg.

The **PORTEO** is neither suitable for application in escape routes, nor at fire doors (fire and smoke doors) and at exterior doors.

The maximum cable length for external components must not exceed 30 m.

The system is connected to the door leaf via slide channel or standard arm.

Limitation of liability

The **PORTEO** may only be used according to its specified intended application.

The **DORMA GmH + Co. KG** will not accept any liability for damage resulting from unauthorised modifications of the **PORTEO**.

Furthermore components/accessories that have not been approved by **DORMA** are exempt from liability.

Safety instructions

-  **Work on electrical equipment may only be performed by properly qualified staff (electricians).**
- Do not allow children to play with the **PORTEO** or its adjustment and control devices.
 - Keep remote controls out of reach of children.
 - Never stick metal objects into the openings of the **PORTEO**; doing so may result in electric shock.
 - If the **PORTEO** is mounted onto a metal door leaf, you have to earth (ground) the door leaf properly.
 - Glass door leaves have to be made of safety glass.

Important technical data

Weight of PORTEO	3,2 kg
Power supply	230V AC or 100V AC (± 15%)
Fuse (by others)	10 A
Operating noise	< 70 dB(A)
Temperature range	-15 °C – 50 °C
Only suitable for dry environments	relative humidity max. 93% non-condensing

Standards, laws, codes and regulations

The latest versions of the common and country-specific standards, laws, codes and regulations have to be observed.

DIN 18650 (German Industrial Standard)

During the planning of the door system, the manufacturer (the person installing the system) and the commissioner/facility operator have to perform an individual risk assessment (together). Please refer to our homepage www.dorma.com and consider the provided "risk assessment form" under **PRODUCT** for further assistance when performing your individual risk assessment.

Dangers at closing edges

Automatic doors may cause hazards by crushing, shearing, hitting and drawing-in at the different closing edges.

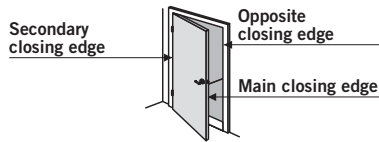

Dangers caused by slide channel and arm

The slide channel and the arm might cause hazards by crushing and shearing.

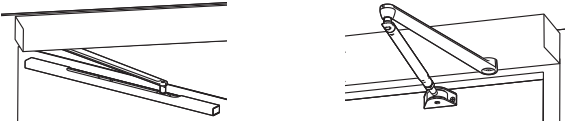

Residual risk

Depending on the structural conditions, the prevailing door version and the available safety equipment, residual risks such as crushing and hitting (with a limited force) cannot be excluded. All people using a door are generally aware of the danger spot at the secondary closing edge of every swing door (also at manually operated doors).

This danger spot cannot be influenced by the manufacturer of the operator and a protection of this closing edge often cannot be realised due to its construction and technical function. A suitable clamping protection (like a rubber or textile cover) is available in the specialised trade and not part of the scope of delivery.

Low-energy product

The **PORTEO** meets the requirements of a low-energy application in accordance with the German DIN 18650 (industrial standard).

- Reduced dynamic force at door leaf and reduced contact force via low driving speed.
- Reduced static force at door leaf and reduced contact force via force limitation.

The door system does not compulsorily require additional safety equipment.

The application of safety sensors at the main closing edge and the secondary closing edges as additional safety equipment is optional and lies in the discretion of the person performing the installation of the door system - under consideration of the result of the individual risk assessment.

Risk assessment on the part of the installer

Due to special spatial conditions and the expected user groups of the door, the application of safety sensors could be reasonable also for a low-energy operator. Thus the manufacturer, i.e. the installer of the system, has to perform an individual risk assessment during the planning of the door system in order to decide whether additional safety equipment is required or not.

Please refer to our homepage www.dorma.com and consider the provided "risk assessment form" under **PRODUCT** for further assistance when performing your individual risk assessment.

Special requirements regarding the protection of people in need of protection

In case the risk assessment reveals that there is a health risk or risk of injury caused by the door hitting a person using the door with an unacceptable force, an additional protection with the aid of appropriate safety equipment (connection of a safety sensor) is required. This is especially necessary when people in need of protection (children, elderly people or disabled people) use the door.

Recycling and disposal



Both the **PORTEO** and its packing mainly consist of recyclable raw material.

The **PORTEO** and the respective accessories must not be disposed of as domestic waste.

Please ensure that the old appliance and the respective accessories (if available) are properly disposed of.

Please abide by the prevailing national statutory provisions and local laws.

Safety during mounting

- The working area has to be secured against unauthorised access from other people. Falling items or tools may cause injuries.
- The **PORTEO** has to be protected against water and other liquids.
- In any case, the way of mounting and the mounting equipment, like for example screws and wall plugs, have to be adequate with regard to the structural conditions (steel structure, wood, concrete etc.).
- Before installing the **PORTEO** the door leaf has to be checked with respect to proper mechanical condition and smooth running.
- The mounting of the **PORTEO** described herein is only an example. Structural or local conditions, available tools or other conditions might suggest a different approach.
- Following the successful installation of the system, the settings and the proper function of the **PORTEO** and the safety equipment have to be checked.
- Only specially qualified staff may open the power supply housing.
- Disconnect the **PORTEO** from power supply (de-energise the system) before removing the cover of the power supply housing. Remove mains plug or switch off fuse (with permanent power supply).
- Always pull at the plug and never at the cable when unplugging the power supply.

Safety during commissioning

- The protective earth conductor has to be connected.
- The safety sensors are to be connected (see commissioning instructions).
- Separately supplied components such as the program switch, the EMERGENCY OFF pushbutton and activators (radar motion detectors, NIGHT-/BANK key switches) have to be mounted and connected.
- Ensure that the door leaves run smoothly
- The operator and the door leaf must be properly linked.

Inspection and system approval

Before the first commissioning and depending on requirements, however, at least once a year, the **PORTEO** has to be inspected by a properly qualified technician and serviced if required.

A person trained by DORMA has to perform the inspection and approve the system with the aid of the inspection book.

The respective results have to be documented in accordance with DIN 18650-2 and other local laws and standards and the facility operator has to keep these documents for at least one year.

PORTEO

We would recommend taking out a maintenance agreement with **DORMA**.

Briefing

Following the adjustment, commissioning and functional testing of the door system, the operating instructions have to be handed over to the facility operator and a briefing has to be made.

Maintenance

The system has to be de-energised (disconnected from power supply) before performing any kind of maintenance work. Remove the power plug or switch off the fuse (with permanent power supply).

We would recommend taking out a maintenance agreement with **DORMA**.

Care

The system has to be de-energised (disconnected from power supply) before cleaning the system. Remove the power plug or switch off the fuse (with permanent power supply).

You may clean the **PORTEO** with a damp cloth and standard commercial detergents.

You should not use scouring agents for cleaning purposes as they might damage the surface finish.

Ensure that no water or other liquids drop on or into the **PORTEO**

Never stick metal objects into the openings of the **PORTEO** doing so may result in electric shock.

Wear



The slide piece has to be inspected at regular intervals (every year) and replaced if required.

Only use original spare parts.

PORTEO -certified safety



Developed according to the latest safety standards:

- + “low energy” according to DIN 18650
- +  TÜV approval
- +  mark
- +  GGT-seal of approval

The TÜV certificate and the -certificate can be obtained from the manufacturer on demand.



reddot design award
winner 2005



JANJIS
DE L'INDUSTRIE



PLUS X AWARD
Awarded for
Ease of Use



universal
design award 08

PORTEO

2. Standard scope of delivery

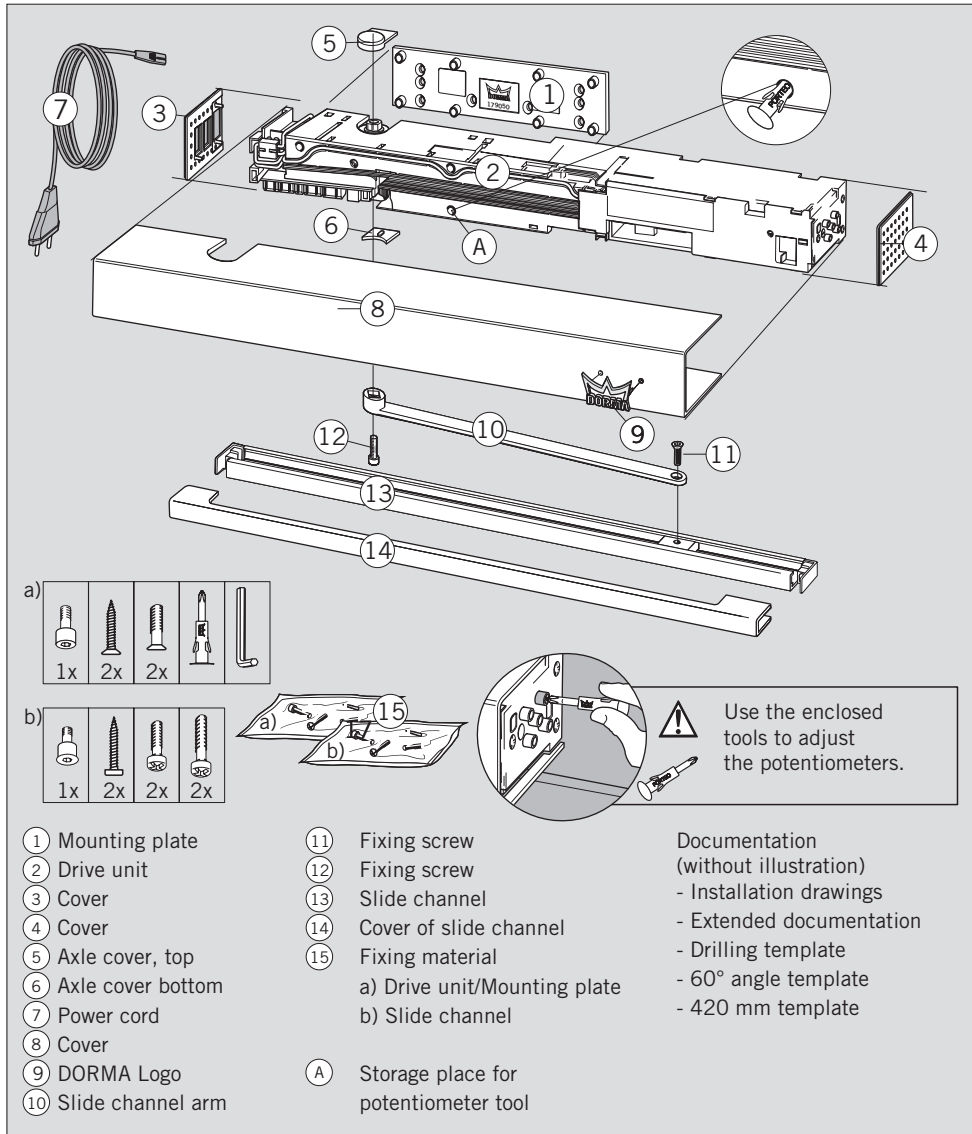



Status on delivery

The operator is supplied with a mains plug. Ready-to-plug-in incl. power cord.

A 2-pole-and-earth mains plug with 10 A fuse protection must be available. The power supply (230V AC or 100 V AC (± 15%), 50/60 Hz, 65 VA, IP 20) has to be provided by others.

PORTEO

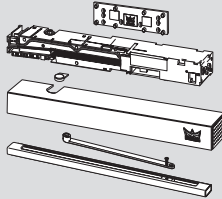
3. Status on delivery and assistance when it comes to selecting appropriate accessories

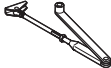
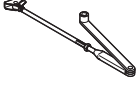
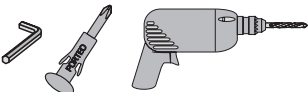
Required accessories for the respective way of mounting		
<p>Lintel mounting:</p> <ul style="list-style-type: none"> – on the hinge side (pull-side), left-handed version – on the hinge side (pull-side), right-handed version – on opposite hinge side (push-side), left-handed version – on opposite hinge side (push-side), right-handed version 		<p>▶ Obligatory accessories</p> <p>none</p>
<p>Door-leaf mounting:</p> <ul style="list-style-type: none"> – on the hinge side (pull-side), left-handed version – on the hinge side (pull-side), right-handed version – on the opposite hinge side (push-side), left-handed version – on the opposite hinge side (push-side), right-handed version <p>⚠ When it comes to door-leaf mounting, the power cord has to be protected from crushing.</p>	<p>Standard</p> 	<p>▶ Cable loop -option Art.-No. 60041401</p> 
<p>Option</p> <p>Lintel mounting with projecting arm. Compulsory for lintel depths beyond 30 mm:</p> <ul style="list-style-type: none"> – on the opposite hinge side (push-side), left-handed version – on the opposite hinge side (push-side), right-handed version <p>⚠ On application of the projecting arm, the slide channel is no longer required.</p>		<p>▶ Projecting arm</p> <p>Lintel depths from 30 to 90 mm</p>  <p>Lintel depths from 90 to 200 mm</p>  <p>Please ask for our template WN-No.: 057193-45532</p>
<p>Required tools for the installation of the PORTEO door assistant</p>		
<ul style="list-style-type: none"> – Allen key, 5 mm (Scope of delivery) – Potentiometer-tool (Scope of delivery) – Power drill – Drill bit, depending on surface 		
<p>Authorised DORMA specialist dealers offer competent advice and the required accessories for the PORTEO door assistant.</p>		

PORTEO

4. "Door basics" technical terms

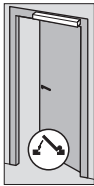
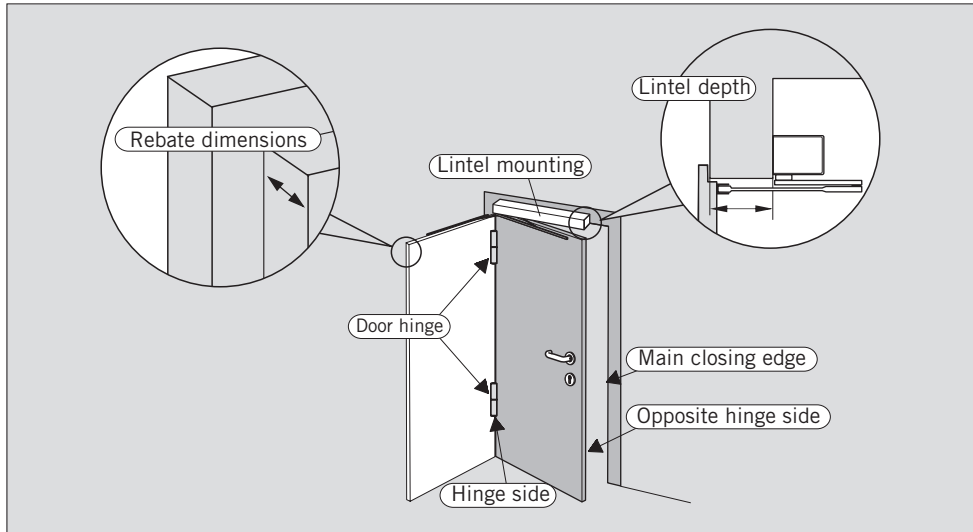

Example 1

- Lintel mounting on opposite hinge side (push side)
- Left-handed design (right-handed version is laterally reversed)
- **PORTEO door assistant** with slide channel (standard)

A rack & pinion arm has to be applied on the hinge side when it comes to lintel depths of more than 30 mm.

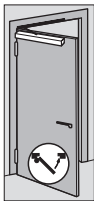

Example 2

- Door leaf mounting on hinge side (pull side)
- Left-handed design (right-handed version is laterally reversed)
- **PORTEO door assistant** with slide channel (standard)



Example 3

- Lintel mounting on opposite hinge side (push side)
- Left-handed design (right-handed version is laterally reversed)
- **PORTEO door assistant** with rack & pinion arm (option)

A rack & pinion arm (option) has to be applied on the hinge side when it comes to lintel depths of more than 30 mm.

5. Function and adjustments

General information

The PORTEO door assistant has been pre-adjusted for various kinds of applications (basic settings).

The settings: swing direction, door weight, door width, way of mounting, **“closed”** and **“open”** position are important for the smooth and proper operation of the door system.

Some of these settings are part of the basic settings, others have to be determined while some settings are determined automatically during the learning cycle.

The determination of the settings is a simple and plain procedure that is described on the pages 16 to 21.

Function

The opening or closing cycle is triggered either by active or automatic activators.

The activator sends a signal to the control unit.

The control unit in turn sends the pulse to the motor.

The motor starts and converts the pulse into a movement.

The arm transfers the movement of the motor onto the door.

The door performs either an opening or a closing cycle.

There are either active or automatic activators.

Active activators are for example pushbuttons or door handles while automatic activators are radar motion detectors or sensors.

Settings / Adjustments

The control unit of the PORTEO door assistant requires the following parameter settings for control-internal operations:

- swing direction -left or right
- way of mounting -intel mounting or door leaf mounting
- mounting side -hinge side/pull side or opposite hinge side/push side
- lintel depth (see page 12)
- type of accessory -slide channel (standard) or projecting arm
- door width
- door weight
- position of the door when closed (**“closed” position**)
- position of the door when it is completely open (**“open” position**, freely adjustable)
- and latching action.

Each setting is learnt automatically during commissioning.

Follow the instructions indicated in the commissioning instructions:

- **Standard commissioning** see pages 16 and 17
- **Extended commissioning** see pages 18 to 21

PORTEO

6. Approach to installation and commissioning

1. Determine the power connection, either:
Plug&Go (power connection via power plug)

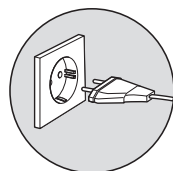

or

Power supply straight through the wall, see page 28 for details.

 This connection version may only be performed by a properly qualified company.

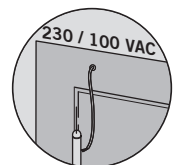

2. **Perform the mounting with the aid of the enclosed installation drawings.**

Select the appropriate installation drawing for your way of mounting.

Lintel mounting with slide channel (standard).

A B C D

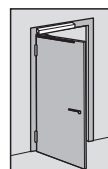

Door leaf mounting with slide channel

E F G H

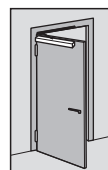

Lintel depth mounting, with projecting arm (option).

Please ask for the template

WN-No.: 057193-45532

I J

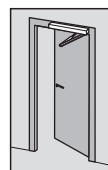

3. **Following the installation, commission the PORTEO door assistant.**

Either with **standard commissioning**,
see operating instructions on page 16 and 17

or

with **extended commissioning**,
see operating instructions on page 18 to 21.

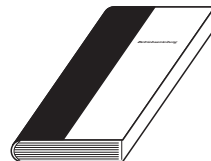

PORTEO

7. Requirements for standard commissioning

Basic settings

The basic settings offer base values for these settings:

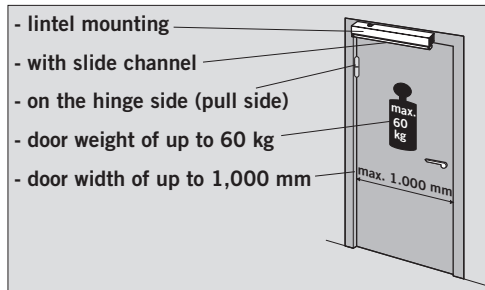

▶ Most interior doors have a door width of less than 1,000 mm and a door weight of less than 60 kg. As far as the structural conditions as well as the basic values of the lintel-mounted operator with slide channel on the hinge side (pull side) correspond to the above-mentioned basic values, the door closer can be commissioned with the aid of the **standard commissioning**.

Deviations from basic values of original settings

In case the basic values are not identical with the basic values of the **original settings**, the deviant settings have to be determined and adjusted during the **extended commissioning**.

page 18 to page 21

Door leaf width and admissible maximum weights

door leaf width in mm	max. door weights in kg
600	140
700	130
800	120
900	110
1,000	100
1,100	100



In case the basic values are not identical with the basic settings, the deviant settings have to be determined and adjusted.

The deviant settings are determined and readjusted during the **“extended commissioning”**.

PORTEO

8. Standard commissioning

Standard commissioning

Requirements

- The **PORTEO door assistant** has been installed.
- The door can easily be moved by hand.
- Perform the following steps of the **standard commissioning** one after the other.
- The (visual) acknowledgement is made via the light indicator (LED).
- You can stop and restart this procedure at any time by simply switching off the system.

The stored settings can be "overwritten" by a new commissioning procedure.

The "approach" describes the commissioning of the standard system.

Accessories like for example electric strikes or sensors are adjusted following the successful commissioning of the system.

1 Close door

- Connect power plug.(2 x 0,75)

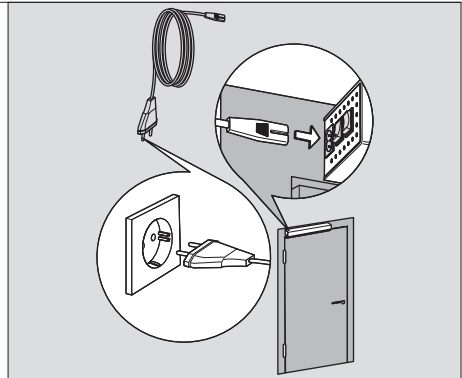

2 Set power switch to "OFF"

- Set program switch to "0" position (central position).

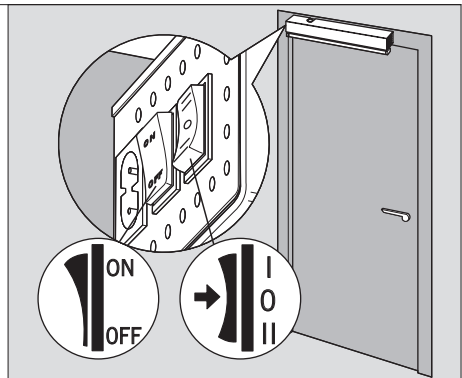

PORTEO

3 Determination of swing direction:

- Open door by approximately 5°.

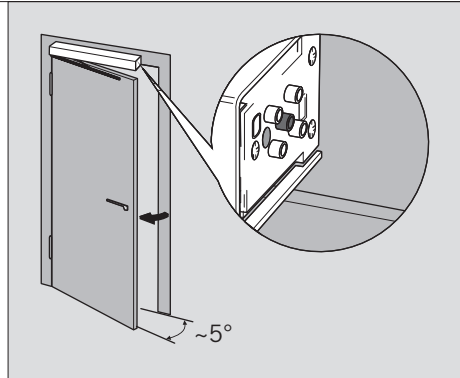

4 Determination of swing direction: Simultaneously, until the door starts moving,

- Press service key and switch on power switch. **Press and hold** service key for **8 sec.** until the door starts moving, then release the service key.

- ▶ The LED (green) blinks.

The door determines the swing direction and travels to its **“closed” position**.

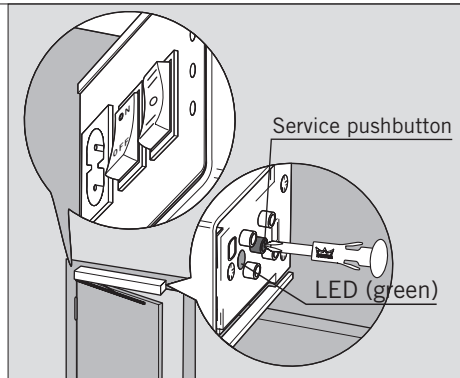

5 Determination of “open” position:

- Move door to desired **“open” position**.

- ▶ The LED (green) blinks.
- Press service key once
- ▶ The LED emits a permanent light for 3 sec., then it blinks

The door determines this position as its **“open” position**. The door travels to its **“closed” position**.

- ▶ The LED (green) emits permanent light.

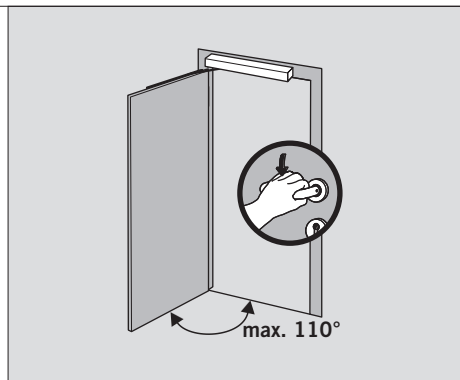

6 Following the learning cycle, the PORTEO door assistant is ready for operation.

Now you can perform further adjustments like speed, hold-open time or adjustments regarding the optional accessories like for example the electric strike, see **adjustments page 24 and 25**.

PORTEO

9. Extended commissioning

When it comes to deviations from the basic values of the original settings (see page 15), an extended commissioning is required.

For example:

- projecting arm instead of slide channel
- a different door width (more than 1,000 mm)
- a different door weight more than 60 kg)

Approach in case of extended commissioning and learning cycle

You can stop and restart this procedure at any time by simply switching off the system.

Requirements:

- The **PORTEO door assistant** has been installed.
- The door can easily be moved by hand.

The stored settings can be “overwritten” by a new commissioning procedure.

The “approach” describes the commissioning of the **PORTEO door assistant** without any accessory.

Accessories like for example electric strikes or sensors are adjusted following the successful commissioning of the system.

Extended commissioning

Preparation 1

Close the door.



Preparation 2

Select an arm version:

Set DIP switch to “A” position

- “ON” = projecting arm
- “OFF” = slide channel

(Set the switch to the correct position with the aid of a small screwdriver.)



Following commissioning the DIP switch “A” has a different function, see page 25
“latching action”

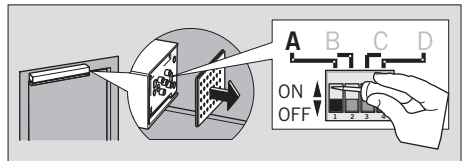
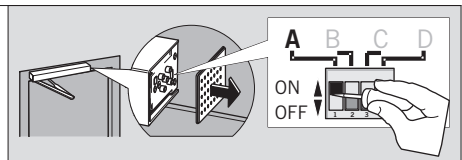

Always set DIP switches “B”, “C” and “D” to “OFF” position

PORTEO

- 1** Connect power plug. (2 x 0,75)

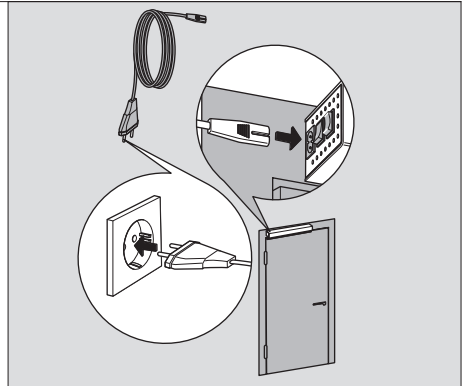

- 2** Set power switch to “ON” position.
– Set program switch to “OFF” position (central position).

► The LED (green) blinks.

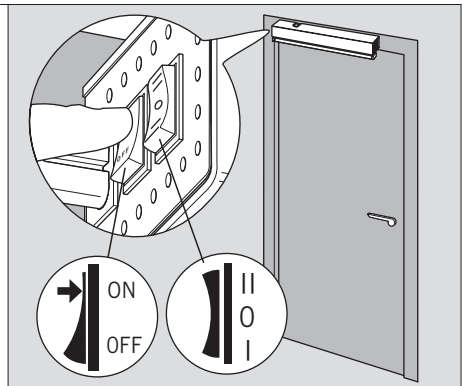

- 3** Determination of swing direction:

– Open door by approximately 5°.

► The LED (green) blinks.

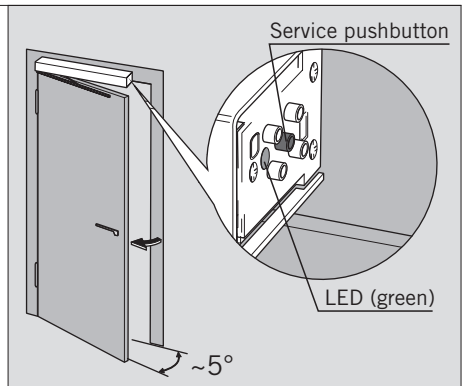

PORTEO

9. Extended commissioning

4 Determination of swing direction:

- Press service key, until the door starts moving (approx. 3 sec.).
- ▶ The LED (green) emits a permanent light for 3 sec., then it blinks

During this procedure the control unit determines and stores the swing direction of the door.

The door travels to “closed” position.

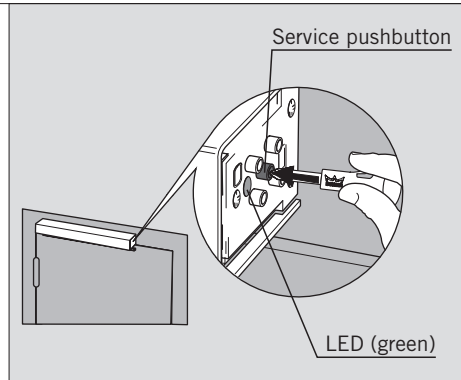

5 Teaching-in the way of mounting and arm version:

- Open door by approximately 60°.
(60° angle template is enclosed).
- ▶ The LED (green) blinks.
- Press service key once.
- ▶ The LED (green) emits a permanent light for 3 sec., then it blinks

During this procedure the control unit determines and stores the way of mounting and the arm version.

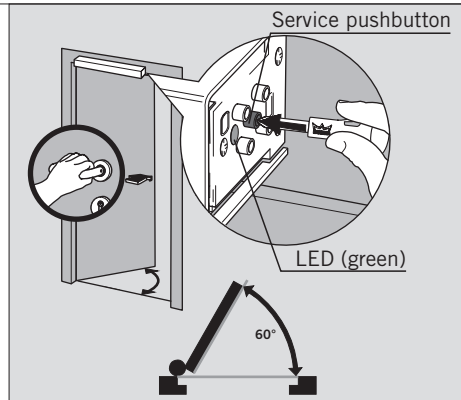

6 Teaching-in the door width:

- Open the door by approximately 420 mm
(420 mm angle template is enclosed).
- ▶ The LED (green) blinks.
- Press service key once.
- ▶ The LED (green) emits a permanent light for 3 sec., then it blinks

During this procedure the control unit determines and stores the door width.

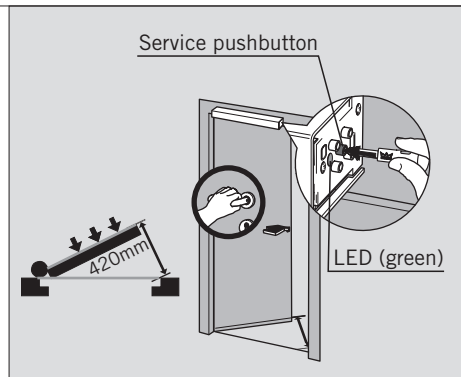

PORTEO

7 Determination of "open" position:

- Move door to desired "open" position
- Press service key once.

- ▶ The LED (green) emits a permanent light for 3 sec., then it blinks

The control unit stores this position as "open" position.

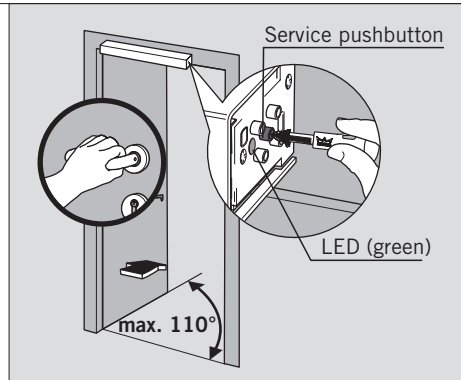

After 10 seconds, the door closes at low speed. An automatic learning cycle starts.

⚠ The door performs some movements that must not be interrupted.

Then the door remains in "closed" position.

- ▶ The LED (green) emits a permanent light signal.

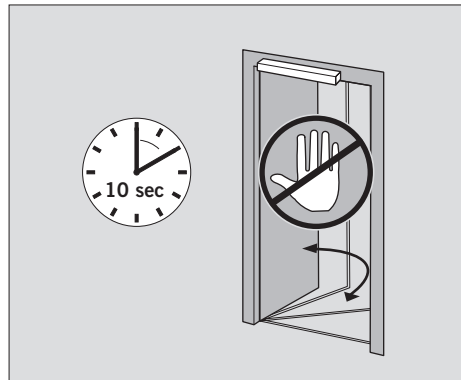

8 Following the commissioning and learning cycle, the PORTEO door assistant is ready for operation.

Further operating instructions.

For adjustments like speed, hold-open time or adjustments regarding the optional accessories like for example the electric strike, see **adjustments page 24 and 25**.

Operating type/functions

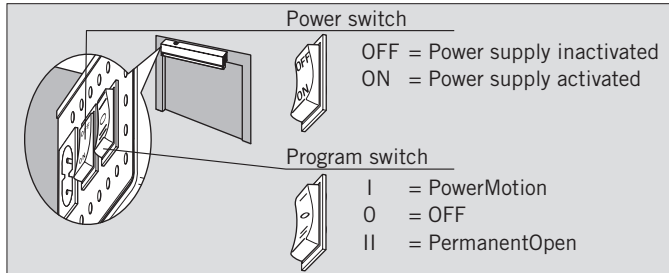

Power switch in "ON" position.

Program switch in "O" (OFF) position.



When in "O" position:

- The electric functions of the **PORTEO door assistant** are switched off
- The **PORTEO door assistant** does not have a function.
- The door can be accessed manually. Either via door handle or key

Program switch in "I" position = "PowerMotion"

When in PowerMotion position, the opening and closing cycles are controlled by activators.



- When an opening pulse is triggered the door opens automatically and closes automatically on expiry of the preset hold-open time (5 sec. to 30 sec.).

Please note! In case an opening pulse is triggered during the hold-open time (while the door is in "open" position), the hold-open time is reset, that means it starts from 0 sec.



Before activating the program switch, you have to ensure that the door is neither closed nor locked. Otherwise the door cannot leave "closed" position.

Program switch in position "II" = "PermanentOpen"



Set program switch in position "PermanentOpen".

When in "PermanentOpen" position:

- The door travels to "open" position and remains in this position, until another operating type is adjusted with the aid of the program switch
- OPTION - "PermanentOpen" with flip-flop function, in program switch position "PowerMotion" with pushbutton or hand-held remote control as activator.**

Press pushbutton twice in short succession or press the programmed pushbutton on the hand-held transmitter once:

- The door travels to "open" position and remains in this position.

The door closes as soon as the pushbutton is pressed again twice in short succession or the programmed pushbutton on the hand-held transmitter is activated again for one time.

Operating type/function "PowerLess"



Program switch in position "1" ("PowerMotion").

During "PowerLess" operation, the door can be opened **manually and without effort**.

Open the door with the door handle. The door closes automatically on expiry of the hold-open time. The "PowerLess" function is adjusted via **potentiometer 1**. See "**Adjustable settings**" page 24 and 25.

Operating type/function "Push&Go"



Program switch in position "1" ("PowerMotion").

Potentiometer 1 must not be set to "PowerLess" position.

The "Push&Go" function is permanently activated during "PowerMotion" operation.

In "Push&Go" mode, the opening pulse is triggered by a manual movement of the door by approx. 3°:

- The door travels to "open" position and closes automatically on expiry of the hold-open time.

When a further opening pulse is triggered during the closing cycle (the door is opened against its swing direction), the door travels back to the adjusted "open" position and closes automatically on expiry of the adjusted hold-open time.

Obstacle recognition

During the opening travel

If the door meets an obstacle during the opening travel, the opening travel is stopped immediately. After approx. 3 sec. the door restarts an opening travel. If the door, meets more than three times an obstacle up to reaching the "open" position, the door drives again into the close position. This procedure repeats itself with each opening impulse, until the obstacle is eliminated.

During closing travel

If the door encounters an obstruction when closing, the closing travel is immediately halted. The door stops at the obstruction. After a few seconds, it travels back a few degrees in OPEN direction and tries to close again after a waiting period. This process is repeated three times. The door then stops and remains at the obstruction. When manually moved approx. 3° in OPEN or CLOSED direction, the door then automatically continues in that direction.

Vandalism mode

The **PORTEO door assistant** has a vandalism mode.

In case the door is pressed against its original driving direction during an opening or closing cycle, the gear is disabled (the door can be operated manually).

Following approx. 5 seconds the door automatically returns to the adjusted function program.

Latching action

The latching action accelerates the closing speed when the door reaches the last few degrees before it closes in order to overcome air resistance, the closing resistance of the latch and the friction/resistance caused by door sealings (if available). The latching action is deactivated on delivery. For adjustments please refer to page 25.

Locking recognition

If an opening signal is generated when the door is locked, the door will push once against the door lock and then switch off. Any repeat opening signal is ignored for 5 sec. . When manually moved in OPEN direction, the door will open and then automatically continue in the specified operating mode.

PORTEO

11. Adjustments

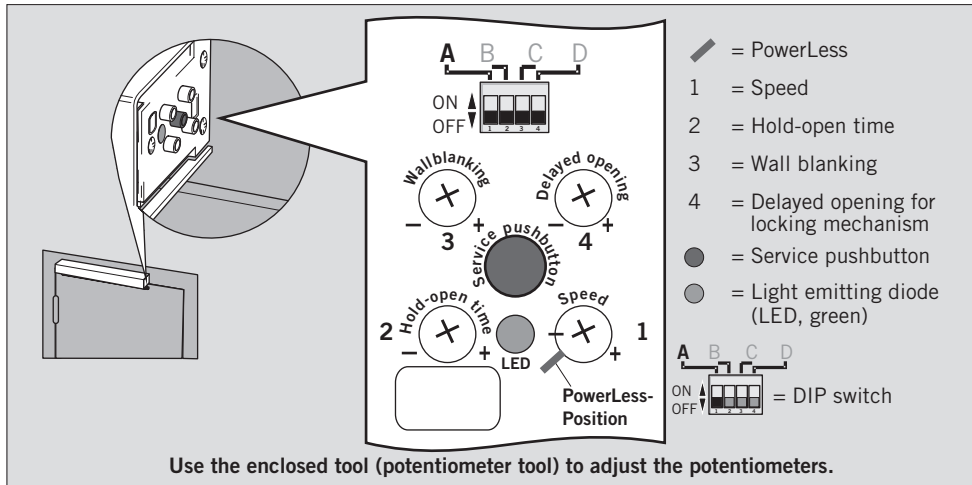

Adjustable settings

The following settings can be adjusted:

- Function "PowerLess"
- Hold-open time
- Wall blanking
- Speed
- Delayed opening for locking mechanism
- Latching action

Adjust the mode of operation "PowerLess"



PowerLess-Position

Set power switch in position "ON".

Set program switch in position "I" ("PowerMotion").

Turn **potentiometer 1** to the left as far as possible to "PowerLess" position.

When in "PowerLess" mode, the door can be opened manually and almost effortlessly.

The door closes automatically on expiry of the adjusted hold-open time.

Adjust the speed



10 sec.

PowerLess-Position

Set power switch in position "ON".

Adjust the desired opening and closing time (speed) via **potentiometer 1**.

The original setting for the driving path from 0° to 90° amounts to 10 seconds.

The original setting for the driving path from 90° to 0° amounts to 10 seconds.

The speed is adjustable from 5 sec. to 10 sec. and is for the driving path for an opening angle from 0° to 90°.

□ = lowest possible speed (driving time = 10 sec.)

+ = highest possible speed (driving time = 5 sec.)



Do not confuse the "PowerLess" position with the **lowest possible speed** (direct in front of "PowerLess").

Adjust hold-open time



Set program switch in position **“ON”**.

Adjust the desired hold-open time via **potentiometer 2**.

The hold-open time is adjustable for a period from approx. 5 sec. to 30 sec.

= 5 sec. hold-open time

+ = 30 sec. hold-open time

Adjustment of hold-open time during **“PowerLess”** operation mode/function.

Turn **potentiometer 1** to **“PowerLess”** position

Adjust the desired hold-open time via **potentiometer 2**.

The hold-open time is adjustable for a period from approx. 0.5 sec. to 30 sec.

= 0,5 sec. hold-open time

+ = 30 sec. hold-open time

Adjust wall blanking (only with optional sensor technology)



Set power switch in position **“ON”**.

Adjust the wall blanking via **potentiometer 3**.

The wall blanking is adjustable from approx. 80° to 110°.

= 80° opening angle

+ = 110° opening angle

Adjustment for a release buzzer (optional)

If an electronic release buzzer is connected, this is detected automatically.



Setting the release time

Set the release time using the potentiometer 4.

The release time is continuously variable from approx. 0.2 sec. to 3 sec.

= 0.2 sec. of delayed release time

+ = 3 sec. of delayed release time

Adjustment of latching action



Following initial operation, the **DIP switch A** takes on a different function.

It can then be used to adjust the latching action.

The previous settings (arm version) do not change.

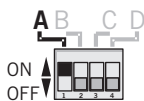

1. Set **DIP switch A** to **“OFF”** position.

Latching action is deactivated.

The door closes gently and is kept in **“DOOR CLOSED”** position.

Suitable for easy-open doors.

2. Set **DIP switch A** to **“ON”** position.

Latching action is activated.

Latching accelerates just before **“DOOR CLOSED”** position.

The door is released once closed.

Suitable for doors with high resistance

PORTEO

12. Connection diagram for accessories

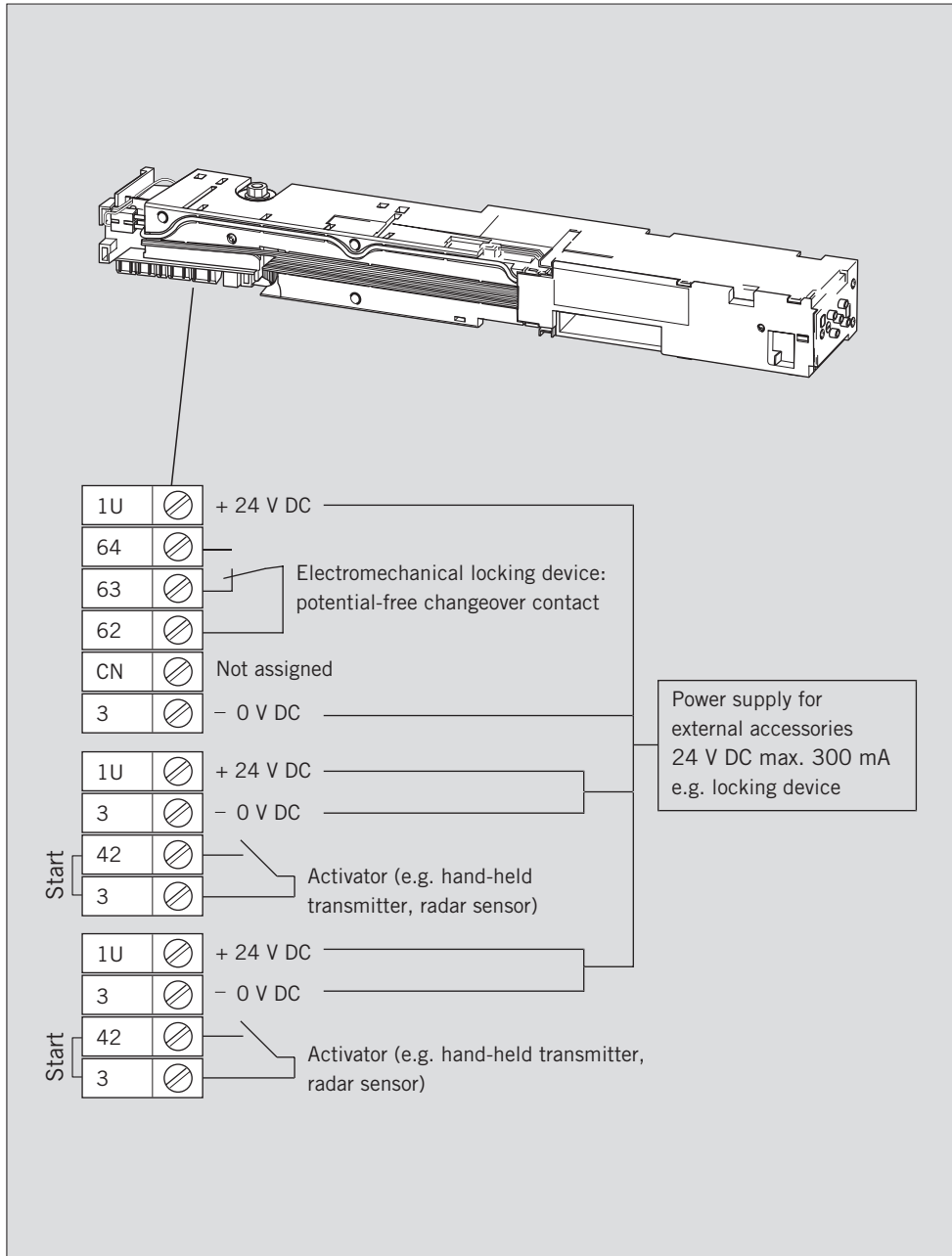

PORTEO

13. Connection diagram: electric strike

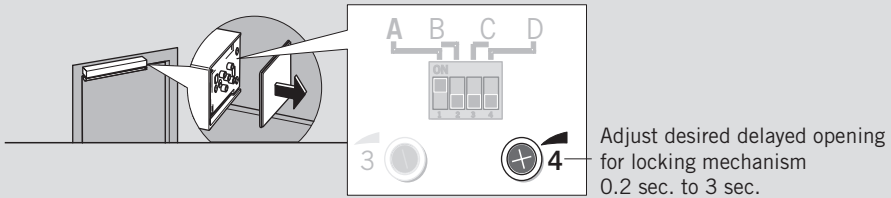

Locking device (fail-secure type) with integrated 24 V DC power supply

FAIL-SECURE DESIGN

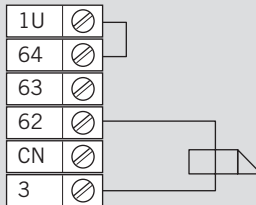

Locking device (fail-safe type) with integrated 24 V DC power supply

FAIL-SAFE DESIGN

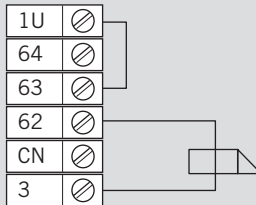

Locking device (fail-secure type) with external 24 V DC power supply

FAIL-SECURE DESIGN

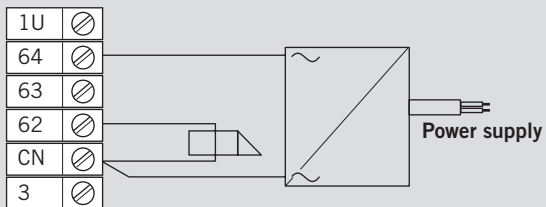

Locking device (fail-safe type) with external 24 V DC power supply

FAIL-SAFE DESIGN

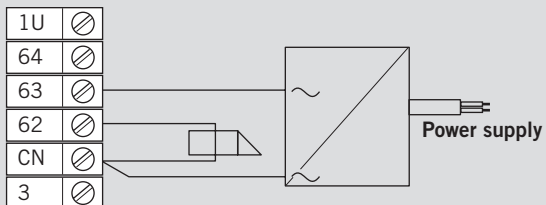

PORTEO

14. Direct power supply, straight out of the wall

1 Before installation

⚠ This connection version may only be performed by a properly qualified company.

Disconnect system from power supply (remove fuse).

The drawing shows a left-handed installation. The right-handed installation is laterally reversed.

Power supply

The power cord must come out of the wall in the position indicated on the picture (installation of cord by others).

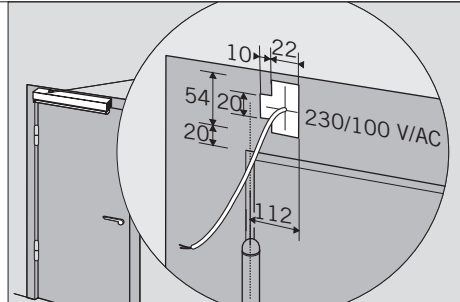

2 Unscrew the cables of the power cord before starting with the installation.

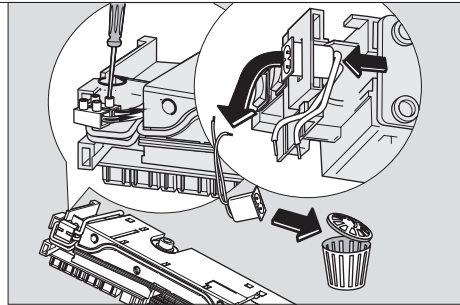

3 Install PORTEO.

Put the cable into the intended "slot" during the installation.

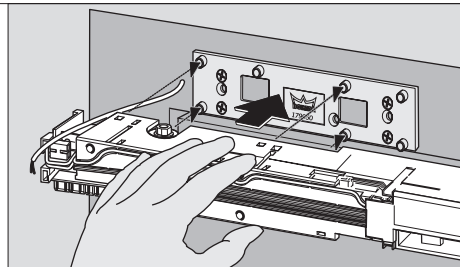

4 Fit connection bayonets. Protect the cables with the aid of silicone tubes. Screw down cables.

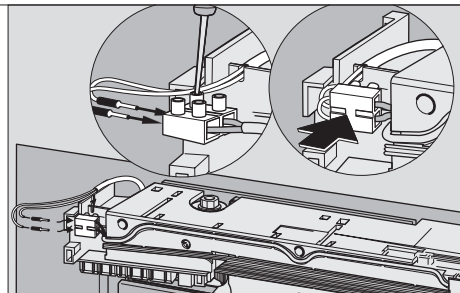

PORTEO

15. Accessories

Mounting plates, 30 mm and 40 mm

For mounting of slide channel at door frames that are not suitable for direct mounting.

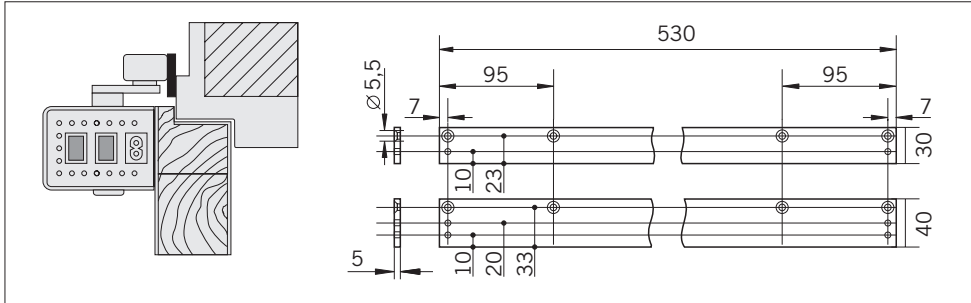

Angle bracket

For installation of slide channel on opposite hinge side (push side) when it comes to door frames with deep lintel. Safety sensors (optional).

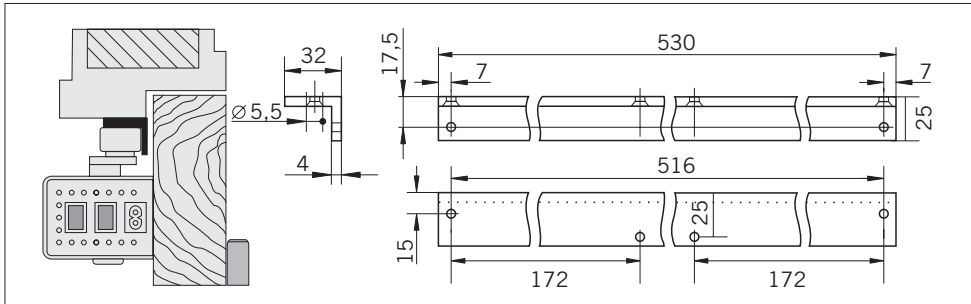

Glass door clamping rail

In order to fix the slide channel to all-glass doors no processing of the glass is required. Only for lintel mounting on hinge side.

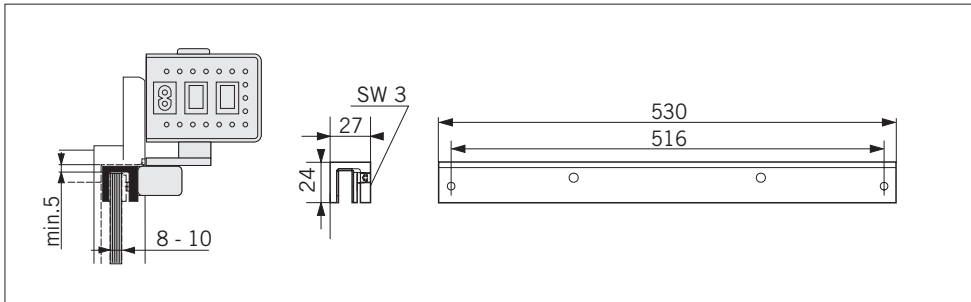

PORTEO

15. Accessories

Electric strike - Type Basic

Standard fail-secure electric strike of symmetrical design with adjustable latch, non-handed, suitable for overrebated and flush-closing doors (any position), including free-wheeling diode supplied loose for the DC versions. See enclosed installation instructions for installation and electrical connections.

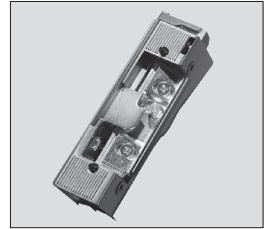

Safety sensors (optional)

When the risk assessment reveals that the application of contactless safety devices is required, the swing range of the door has to be protected by **DORMA IRS-4** moving active infrared sensors. In this case the **PORTEO door assistant** has to be equipped with another connection unit, the **DORMA Comfort Board**.

Please contact your DORMA specialist dealer for further information.

Manual release switch DORMA system 55 (option)

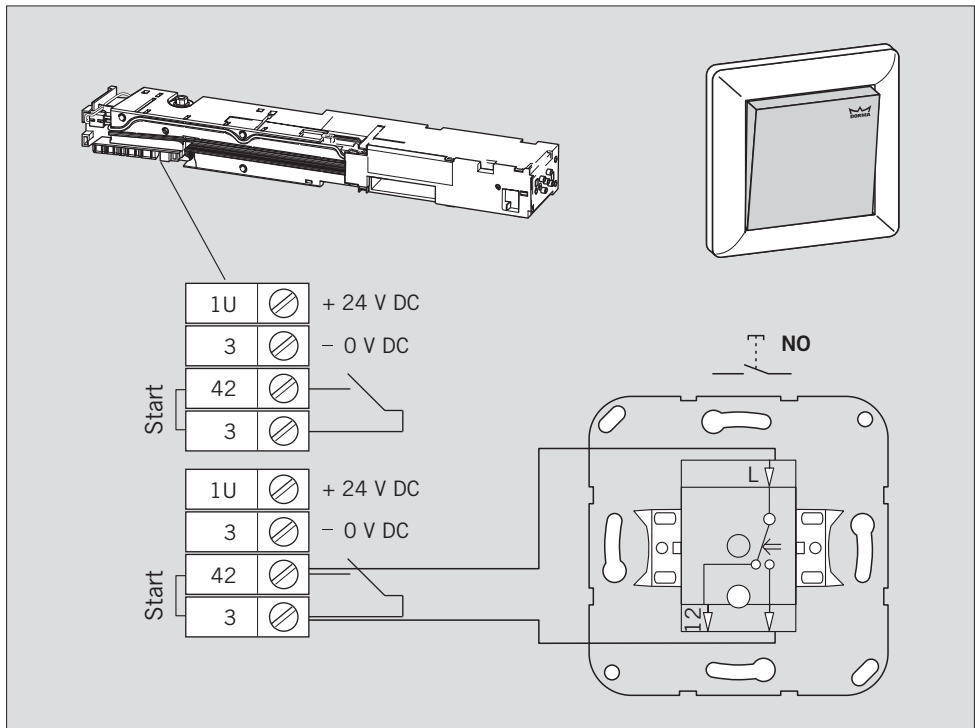

PORTEO

16. Hand-held transmitter DORMA atent

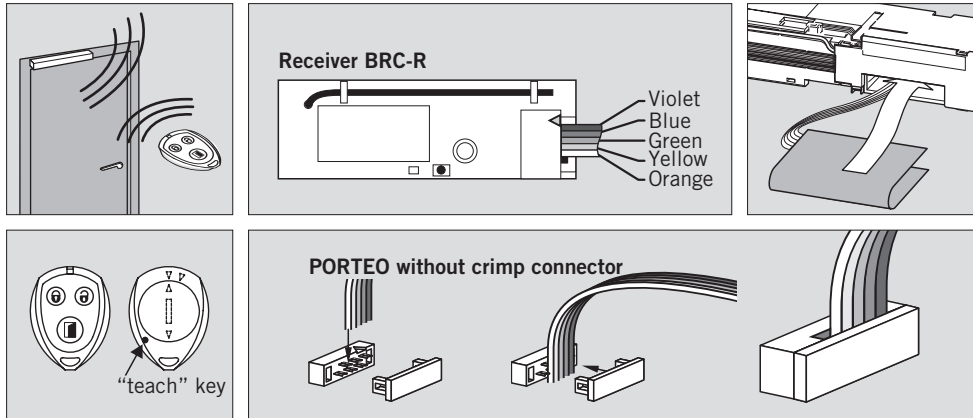

DORMA atent radio remote control

DORMA atent is designed to open and close doors automatically via radio control.

An infinite number of hand-held transmitters may be allocated to the PORTEO. Every handheld transmitter has to be programmed individually.

The **BRC-R** receiver board (to be ordered separately) is inserted in the provided slot at the **PORTEO**. It is possible to connect the crimp connector of the **PORTEO** direct to the receiver board.

In case the **PORTEO** has not yet been equipped with a crimp connector, the cables of the **PORTEO** may be connected with the aid of the crimp connector accompanying the receiver board. Please connect the violet cable at the side with the arrow marking.

Programming



Activator 1 - PowerMotion (Automatic opening/closing of the door)

1. Activate the "teach" key on the atent **DORMA** with the aid of a suitable object.
2. Press and hold the "teach" key on the **BRC-R** receiver board for 4 seconds. The LED blinks red.
3. Push the respective key  on the **DORMA** atent to activate the PowerMotion function
4. The LED goes out and the programming is completed.



Activator 2 – Permanent Open

1. Activate the "teach" key on the **DORMA atent** with the aid of a suitable object.
2. Shortly push the "teach" key on the **BRC-R** receiver board. The LED blinks red (fast).
3. Then press the "teach" key on the **BRC-R** receiver board again and hold the key for approx. 4 seconds. The red LED now blinks more slowly.
4. Push the respective key  on the **DORMA atent** to activate the Permanent Open function.
5. The LED goes out and the programming is completed.



PORTEO

Functional characteristics

Activator 1 - PowerMotion

-  (Automatic opening/closing of the door)
 - Push the correspondingly programmed key (to open the door) on the hand-held transmitter:
 - The door moves to its “open” position and automatically closes on expiry of the adjusted hold-open time.

Activator 2 - Permanent Open

-  Push the programmed key (to activate the Permanent Open function) on the hand-held transmitter:
 - The door opens and remains in its “open” position.
-  Push the programmed key (to activate the Permanent Closed function) on the hand-held transmitter:
 - The door opens and remains in its “closed” position

Resetting the programming



In order to delete the programming, both the **DORMA atent** and the **BRC-R** receiver board have to be reset.

DORMA atent

1. Press and hold the “teach” key on the **DORMA atent** for more than 5 seconds. The red LED blinks slowly. (If you want to stop the system reset, simply press the „teach” key again for a short time. The red LED no longer blinks slowly but stops blinking.)
2. Press and hold the “teach” key of the **DORMA atent** once more for 5 seconds. The red LED now blinks faster as long as you press and hold the key.
3. As soon as you release the key, the system reset is completed and the LED shows a permanent red light in order to confirm the system reset. The **DORMA atent** has now been reset.





BRC-R receiver board

1. Press and hold the “teach” key on the **BRC-R** receiver board for more than 4 seconds.
2. Press and hold the “teach” key on the **BRC-R** receiver board once more for more than 4 seconds.
3. The system LED blinks fast in order to indicate that the receiver board has been reset successfully.

17. Commissioning, care, maintenance

Commissioning, care and maintenance (requirements according to DIN 18650-2, 5.1-5.4)

DIN 18650 also prescribes safety standards for the commissioning and maintenance of the complete automatic door system. As long as the facility operator intends to use the **PORTEO door assistant** according to this standard, the following requirements prevail:

-  Inspection and acceptance test according to the below-mentioned checklist before the first commissioning by a person trained by us.
-  Regular maintenance and inspection, at least once a year, under consideration of our specifications for the **PORTEO door assistant** by trained staff.
-  Documentation of the results in accordance with DIN 18650-2 paragraph 5.1-5.4
 Safekeeping of the properly filled-out checklist according to our specifications for at least 1 year by the facility operator.

Checklist (start-up test, maintenance, regular inspections) for PORTEO door assistant according to DIN 18650-2, paragraph 5.1-5.4

- Proper installation according to the instructions of the manufacturer.
(Tight fit of the **PORTEO door assistant** to the lintel/frame respectively, or the door leaf.)
- Check door leaf for smooth running and adjust, if required.
- Proper functioning of the door (check the opening and closing cycle respectively).
- Function of installed activators like radar motion detectors, pushbuttons or remote controls.
- Function of the contactless safety equipment (safety sensors), if installed
(only for PORTEO as Full Energy version).
- Installation of effective safety equipment to avoid or protect danger spots between certain parts of the door and between the door and its structural environment, like for example safety clearances or the protection of the secondary closing edges.
- Fix inspection plate.
- Document the inspection and maintenance work.

The **PORTEO door assistant** has to be switched off and secured against unauthorised or unintended switching-on before performing maintenance work (cleaning or maintenance).

18. Troubleshooting instructions

Malfunction	Possible cause	Remedy
The LED light indicator is off. The door does not respond.	No power supply.	Switch on power switch.
	Loose cable connections.	Connect cable connections thoroughly.
	Damaged cable.	Replace cable.
	The power plug is not connected.	Insert power plug.
	The door assistant is defective.	Replace door assistant.
The LED light indicator illuminates. The door does not respond.	The program switch is set to "0" position (central position).	Replace door assistant.
	The program switch is set to position "II" (PermanentOpen)	Set program switch to position "I".
	"PowerLess" mode is adjusted	Adjust "PowerLess" mode via potentiometer 1. See page 22/23.
	The door was opened via the flip-flop function.	Close door via a new pulse. Press the pushbutton twice in quick succession.
	Defective door assistant.	Replace door assistant.
The LED light indicator blinks. The door does not respond.	The learning cycle has not been performed properly.	Restart learning cycle.
	External malfunctions.	Reset system: 1. Program switch to "0" position. 2. Program switch to desired mode. 3. Power switch to "OFF" position. 4. Power switch to "ON" position after 5 sec.
	The electric strike does not open the door.	Set DIP switch A to "ON" position. Check and repair or replace electric strike if required. Check and repair or replace electric connections if required.
	Defective door assistant.	Replace door assistant.
The door stops during a cycle.	The door does not run smoothly.	Check door and driving phase. Remove cause for rough running. Check slide channel for dirt or wear and clean or replace if required.
	There is an obstruction within the door's driving path.	Remove obstruction.

PORTEO

Malfunction	Possible cause	Remedy
The door opens beyond the adjusted opening angle.	Obstacle in driving phase of door. Opening angle incorrectly adjusted.	Remove obstacle. Repeat learning cycle.
	The screws of the slide channel are loose.	Tighten the screws thoroughly.
The door does not reach the adjusted opening angle.	Obstacle in driving phase of door.	Remove obstacle.
	Opening angle incorrectly adjusted.	Repeat learning cycle.
	The screws of the slide channel are loose.	Tighten the screws thoroughly.
The door opens automatically following a closing cycle.	The screws of the slide channel are loose.	Tighten the screws thoroughly.
General malfunctions.		Reset system: 1. Program switch to "0" position. 2. Program switch to desired mode. 3. Program switch to "OFF" position. 4. Program switch to "ON" position after 5 sec.

WN 057096 45532, 12/11, Porteo, GB, 1. DDD. 11/12 · Subject to change without notice

