

SECTION 2
TYPE: O-X2-SX1-SX1-X2-O

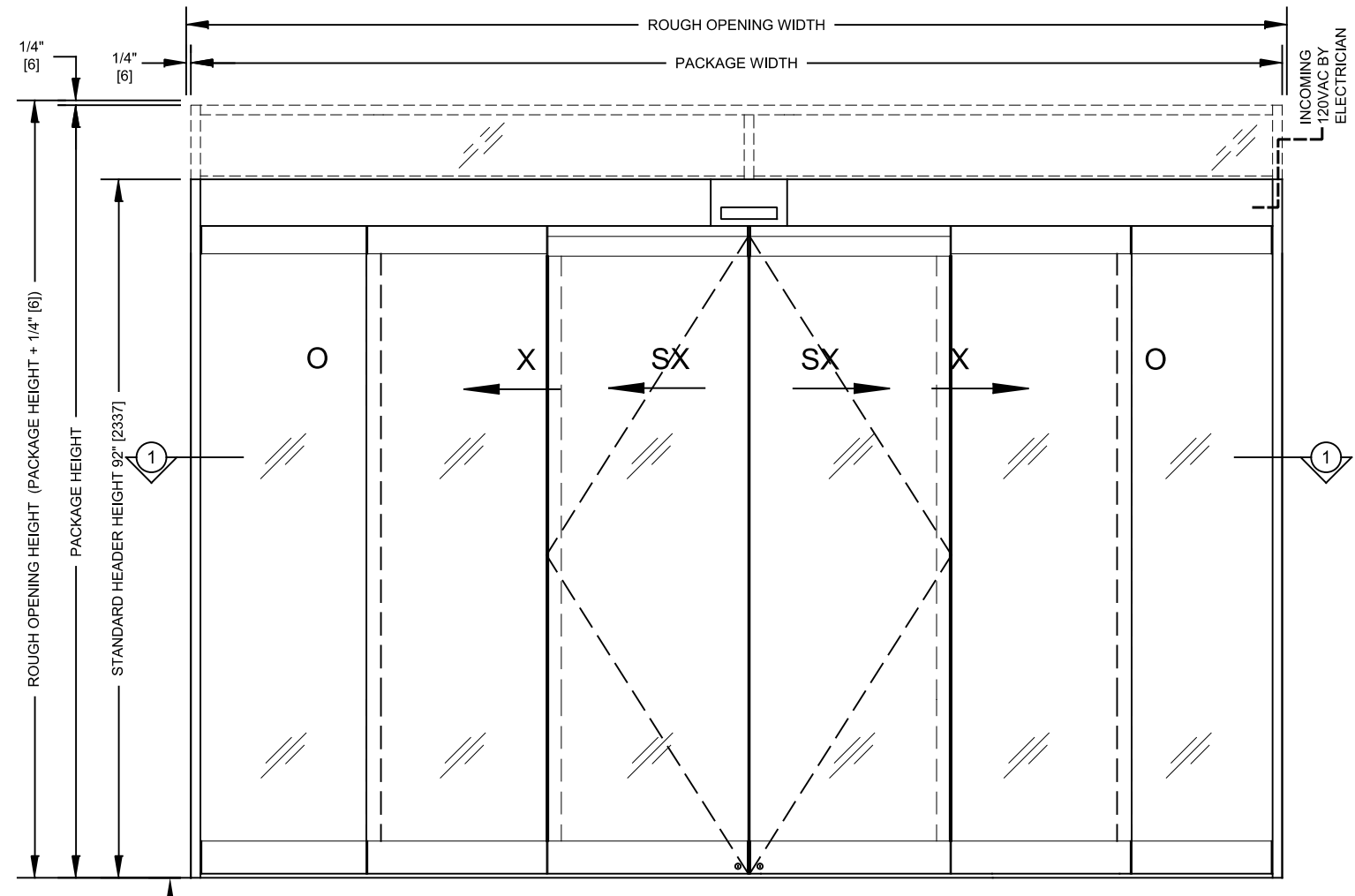

EXTERIOR ELEVATION
TYPE: O-X2-SX1-SX1-X2-O

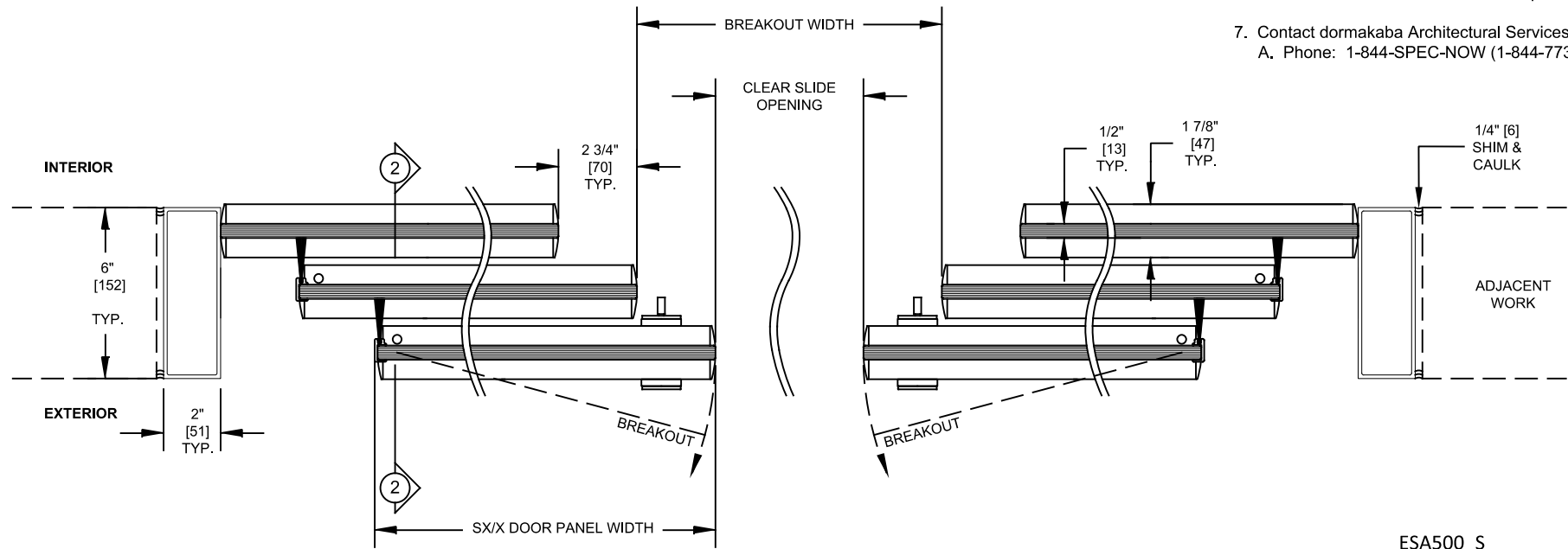

SECTION 1
TYPE: O-X2-SX1-SX1-X2-O

DOOR SHOWN IN OPEN POSITION WITHOUT THRESHOLD

1. This Telescopic All Glass Single door package consists of:
 - A. Operator:
 - Two combination motion/presence sensors (one on each side) (See sensor options page).
 - ESA II motor drive unit with self-learning and self-monitoring microprocessor controller.
 - Jamb mounted 5 function rocker switch panel (see mode switch options page).
 - B. Panels:
 - 6" [152] Bottom rails.
 - 2" [51] X 6" [152] Smooth jambs.
 - Vertical and horizontal brush type weather stripping (AAMA-701-11Class A).
 - ADA compliant srecessed track and threshold 1/2" [13] x 3 5/8" [86].
 - Single point bottom rail mounted mortise lock (full threshold required).
 - Breakaway sliding door panels (SX1) and fixed sidelights (O) panels.
 - 1/2" [13] tempered float glass (not supplied with door).
 - C. Finish:
 - Stainless steel cladding.
3. Typical Package Options:
 - A. Locking and Security Options:
 - Autolock sliding carrier lock concealed in header (only prevents sliding).
4. Drawing Notes:
 - A. Drawing dimensions are in English & Metric units. Metric units are displayed as: 1" [25] millimeters.
 - B. Package Dimensions (May be limited by panel weight):
 - Package Width: Min. 11' [3353] to Max. 16' [4877].
 - Header Height: Min. 7'-4 1/2" [2248] Max. 10' [3048].
 - Package Height: Max. 12' [3658] with Transom.
 - SX Panel Weight: Max. 225 lbs [102 kg].
 - C. Maximum special application limits / custom packages: (Sizes may be restricted due to complexity and application). (Please contact dormakaba Architectural Services for dimensions outside of typical sizes above).
 - Package Width: Min. 11' [3353] to Max. 21' [6401].
 - Package Height: Max. 13' [3962].
 - Header Height: Max. 11' [3353].
 - Transom Height: Min. 8" [203] to Max. 2' [610].
 - SX Panel Width: Max. Width 48" [1219].
 - SX Panel Size Limit = (SX Panel Width x Weight) < 900 ft-lbs [1220 N-m] Max.
 - D. Sidelight is 1/8" proud of jamb towards the interior.
5. Power Requirements:
 - A. 120V +/- 10%, 50/60 Hz, 6.6A peak, 250 W. Up to 4 operators on a single 20A breaker. Service to header by electrician.
6. Standards of Compliance:
 - A. UL 325 & CSA 22.2 (listed with ETL).
 - B. Designed to comply with these standards depending on installation and application:
 - International Building Code (Section 1008).
 - ANSI/ BHMA 156.10.
 - ANSI/ BHMA 156.38.
 - NFPA 101 Life Safety Code (Section 7.2.1.9).
 - C. Refer to Local, State, National or AHJ. Building Code for minimum door height and minimum/maximum width allowable for egress requirements.
 - D. Minimum ADA is 32" clear slide opening.
7. Contact dormakaba Architectural Services for more information:
 - A. Phone: 1-844-SPEC-NOW (1-844-773-2669)