

8000 SERIES BPA/BPAR/DWA ALARM DEVICE

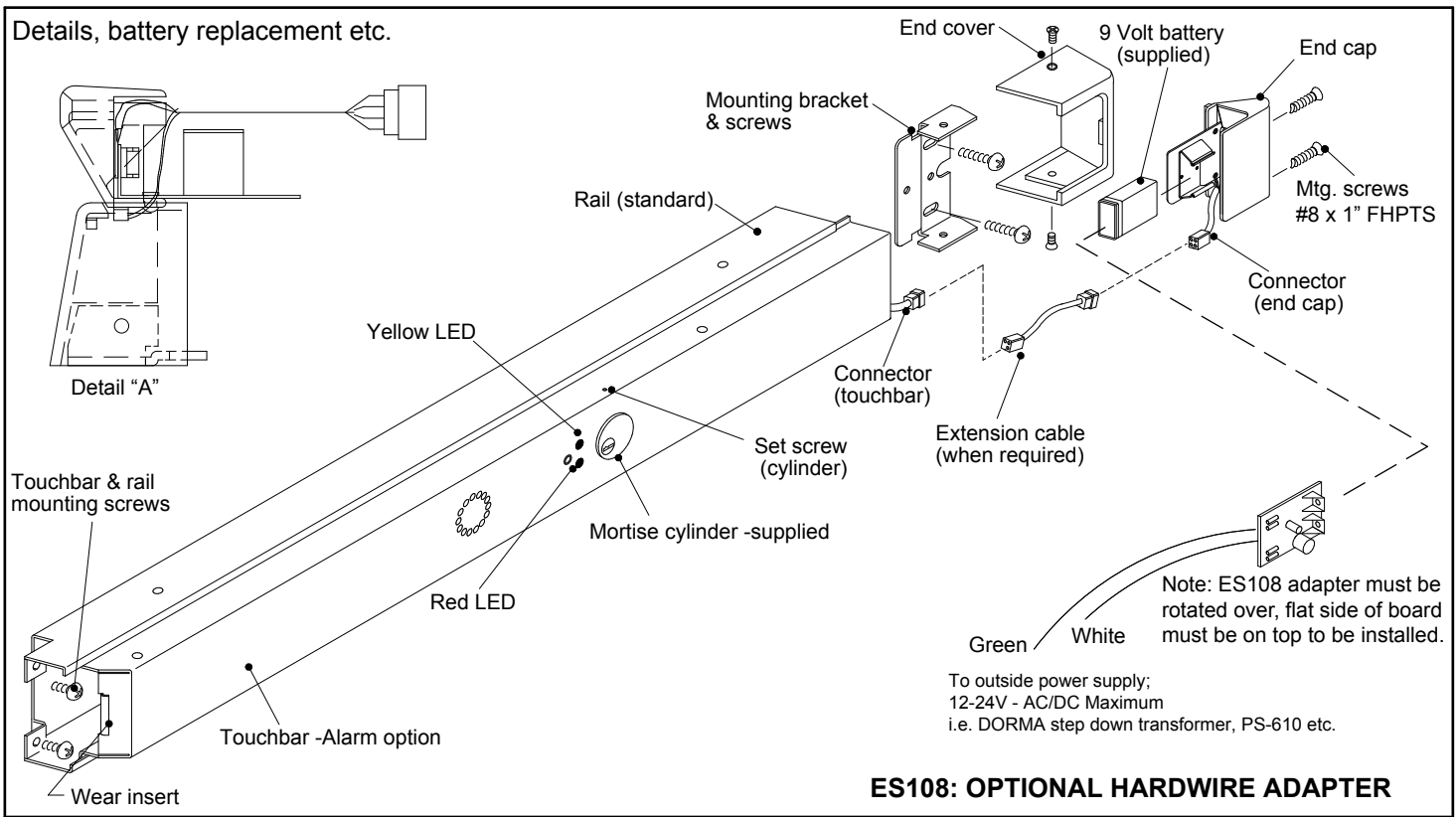

Technical Specifications



Operation of unit

1. Arming - Rotate key counter-clockwise, hold key in position until (2) beeps are heard. You now have 10 seconds for authorized egress before alarm is set.
2. Dis-arming - Rotate key counter-clockwise, hold key in position until (1) beep is heard. Unit is now disarmed.
3. Audible alarm will sound upon exit attempt.
4. Audible alarm will sound if either section of end cap or end cover are attempted to be removed.
5. Red LED flashes periodically to indicate unit is alarmed.
6. Yellow LED is illuminated when alarm sounds.
7. Alarm can be set at factory to sound continuous or be set to rearm after 4 minutes.
8. Unit will emit an audible chirp periodically when it is required to be replaced. Once per year recommended.

Battery replacement

1. Disarm unit by rotating key counter clockwise until 1 beep is heard.
2. Remove 2 screws on sides of end cover, then remove end cover.
3. Remove 2 screws in rear of end cap. Gently remove end cap from touch bar. Remove and replace 9V battery with a new 9V Alkaline battery.
4. Reinstall end cap to touch bar and secure with 2 flat head screws.
5. Trial test unit - by placing end cover on device but not installing screws. Arm unit per above, wait 10 seconds and depress touch bar. Alarm should sound. Disarm, rearm wait 10 seconds and remove end cover, alarm should sound.
6. Replace end cover and secure with 2 truss head screws.
7. Rearm unit, wait 10 seconds and test touch bar. Alarm should sound, if not recheck all previous steps.

Field installation of new or replacement unit requires a new touch bar & rail, as well as end cap/end cover assemblies.