

EM 1800 AH
EM 3000 H
EM 3000 AH
EM 3000 H NF
EM 3000-GL AH

EM 5300 AH
EM 5300 H NF
EM 5300-i AH
EM 5300-GL AH

EM 5300-2 H
EM 5300-2 AH

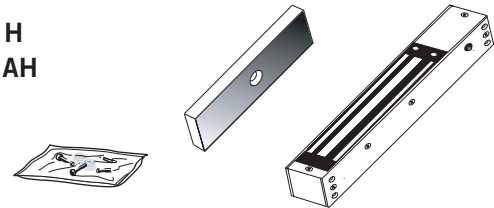

F Note importante

1. La tension d'alimentation doit être suffisante. Voir la notice de raccordement
2. L'alimentation doit fournir un courant suffisant
3. Ne jamais percer ni modifier le verrouillage EM ni la contre plaque

1. The power supply has to be enough for the electromagnet. Look at wiring notice
2. The supply should be able to provide a sufficient voltage
3. The armature plate and the electromagnet should no be drilled or modified

Important notice

F Exemples d'installation

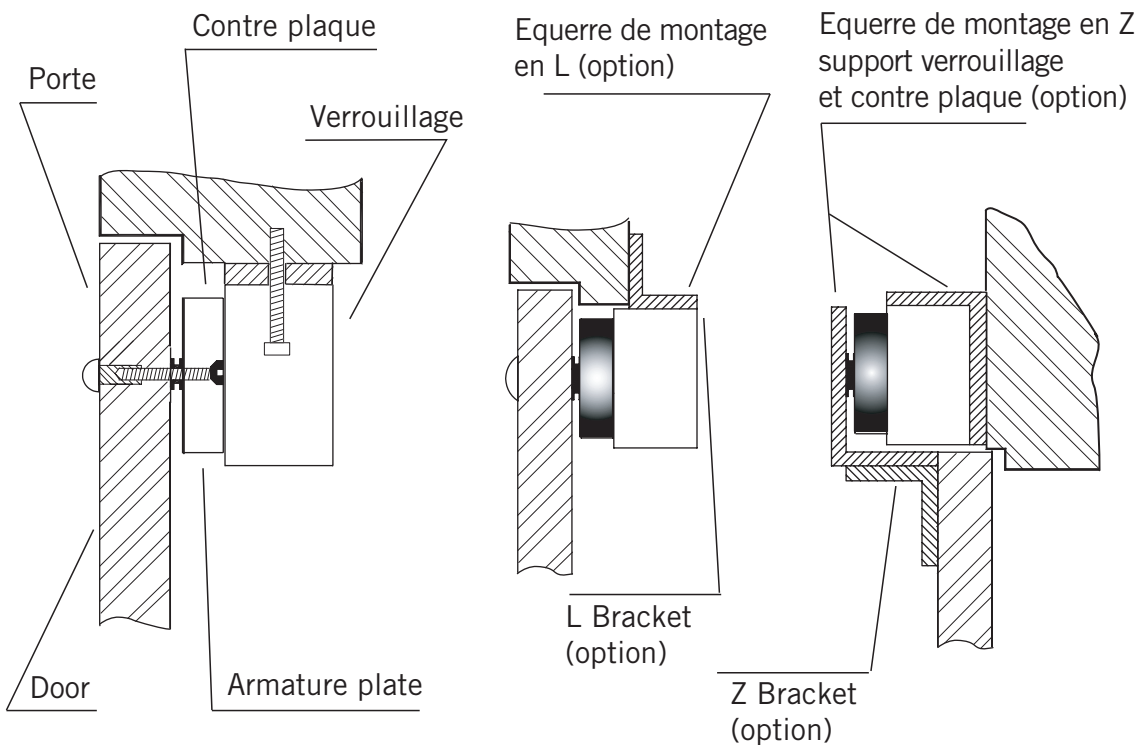

Typical installation

F Pose de la contre plaque



La contre plaque doit être montée selon les dessins ci-dessous. Ne pas serrer trop fort la vis centrale afin que la plaque reste souple

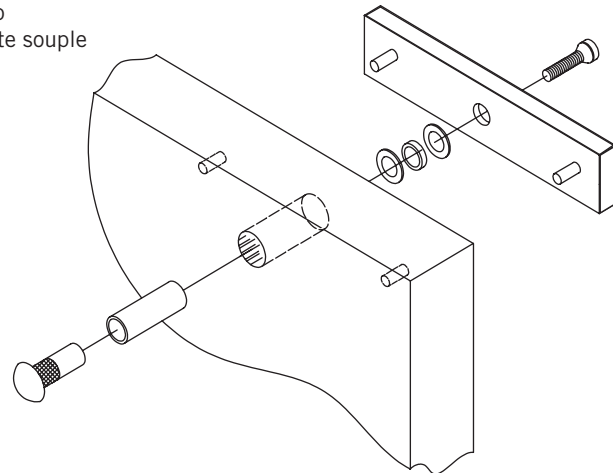
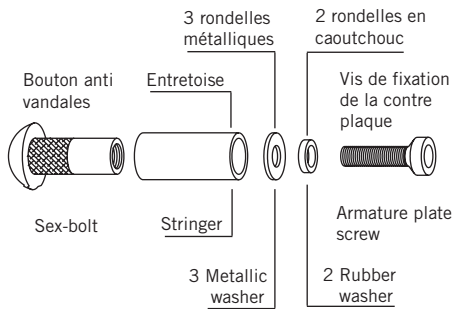

Porte en bois

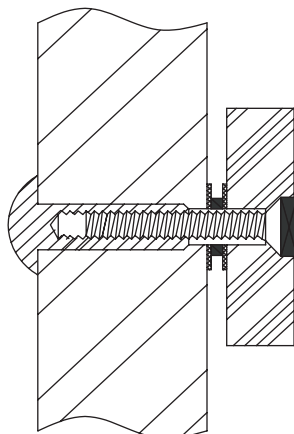

Wooden door

Porte aluminium ou PVC

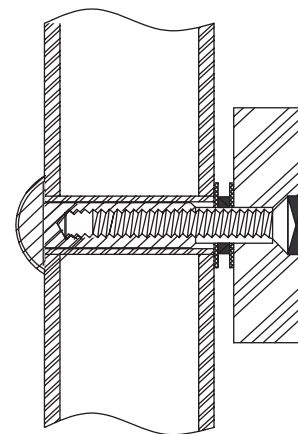

Aluminium or Plastic door

Porte verre 8 ,10 or 12 mm
Cavalier en U (option)

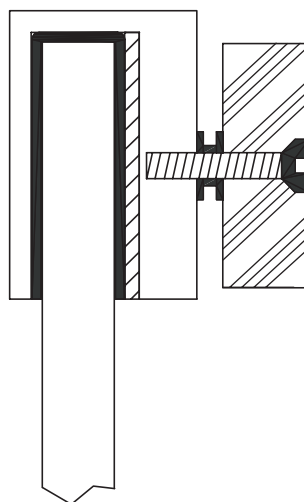

Glass door 8 ,10 or 12 mm
U channel bracket (option)



The armature plate should be mounted as shown above. Do not over-tighten the central screw. The plate must remain flexible

Mounting of the armature plate