

# Ilco 79 Series



### Overview

The Ilco 79 Series door lock offers contactless RFID technology to enhance resident convenience and improve operational efficiency. This RFID solution offers keycard auditing capabilities for enhanced staff monitoring and user accountability. The Ilco 79 lock works with web-based RezShield™ software. In addition the lock will soon be able to operate using the Kaba Mobile Key System and be offered with one of the following options: Bluetooth Low Energy (BLE) ready or BLE enabled.

### Applications

- Suitable for small to very large scale properties
- Easily replaces existing mechanical or electronic door locks
- Access control for individual units, common areas, and back-of-house

### Security Features

- High security and tamper resistant design
- 1" solid deadbolt (optional auto deadbolt)
- Emergency access: Emergency keycard, mechanical key, and electronic override

### Low Maintenance

- Operates with a completely sealed RFID reader
- Designed for extended battery life
- Low battery indicator alerts staff
- Lock programming and audit are not erased during battery replacement
- Wear resistant construction and finish
- Upgradeable lock firmware for future enhancements

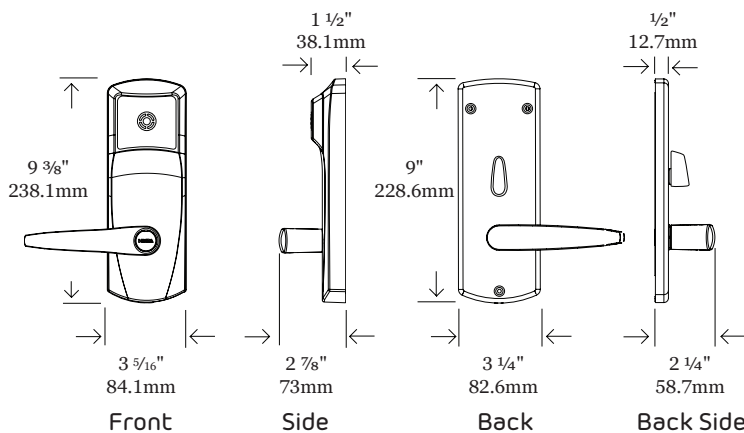

## Mechanical Features

<i>Description</i>	Heavy duty electronic lockset with clutch mechanism and built-in contactless RFID reader (mortise, cylindrical, or exit trim)
<i>Handing</i>	Left or right factory handed mortise, field reversible handing, (lever and mortise, except 1" mortise)
<i>Lever</i>	ADA compliant, outside lever free to rotate upward and downward in locked mode. Lever clearance (space from end of lever to door): Long Lever: 3/8" (9.5mm) Short Lever: 2" (51mm) Elevon and Gala Lever: 2" (58mm)
	
<i>Concealed Key Override (optional)</i>	Ilco KIK Core (keyed-alike, master keyed, recodable) or Best small IC adaptor
<i>Deadbolt</i>	1" (25mm) for ASM mortise solid metal, projected by inside thumbturn and retracted with the latch by the interior handle, emergency override or specific staff keycards. Optional auto deadbolt available.
<i>Door Thickness</i>	From 1 3/8" to 2 1/2" (35mm to 66mm)
<i>Shipping Weight</i>	8.5 lbs (3.8 kg)
<i>Housing Construction</i>	Cast zinc alloy (outside housing levers and thumbturn), stainless steel inside housing
<i>Standard Finishes</i>	Satin Chrome and Satin Brass
<i>Standard Backset</i>	2 3/4" (70mm) backset, 2 3/8" (60mm) backset also available for cylindrical lock
<i>Locking Options</i>	ANSI lock case with 1 1/4" or 1" lock front mortise. Optional automatic deadbolt. Cylindrical latch (2 3/8" or 2 3/4" backset).
<i>Mobile Key Options (BLE)</i>	BLE ready: upgradeable to BLE enabled when available BLE enabled (available in the near future): End cap with BLE module included, no further upgrades needed

## Batteries

<i>Alkaline</i>	Three AA batteries for up to 120,000 openings or up to three years (based on 10 openings per day). Low battery indicator: alerts staff that batteries need to be changed soon.
-----------------	--

## Lock Operation

<i>Date/Time Stamp</i>	Real time: date and hours/minutes
<i>Programming and Audit Trail Downloading</i>	Can be done using a 4K audit keycard or by using Kaba M-Unit
<i>Pre-registered Keycards</i>	Up to 10 days in advance
<i>Keycard Expiry</i>	From one hour to seven years, depending on type and setup
<i>Passage Mode</i>	Set by authorized keycard
<i>Lockout Mode</i>	Set by authorized keycard
<i>Keycards Accepted</i>	RFID cards or tags (ISO 14443, MIFARE Classic (4 Byte NUID), MIFARE Plus and Ultralight C)
<i>Feedback</i>	"Dual sensory" audible and visible indicators
<i>Diagnostics</i>	Built-in battery voltage meter and lock version display
<i>Audit Memory</i>	Last 400 transactions stored in lock (lock audit can be retrieved using M-unit or using lock audit keycard)
<i>Disability Feature</i>	Extended unlock time (4 seconds standard, 15 seconds for disability)
<i>Privacy Override</i>	Default emergency keycard only (user selectable)

## Certification and Testing

<i>Accessibility Standard</i>	ADA compliant levers; thumbturn compliant with optional adapter
<i>BHMA/ANSI</i>	Certified to be compliant with Grade One performance tests for "ANSI/BHMA A156.13-2005 Standard for Mortise Locks and Latches," and "ANSI/BHMA A156.25-2007 Standard for Electrified Locking Devices." (Only locks tested and approved by non-biased third-party test lab are allowed in the "BHMA Certified Products Directory" found at <a href="http://www.buildershardware.com">www.buildershardware.com</a> ).
<i>Fire Rating</i>	Listed for pre-prepared manufactured doors and certified for retrofitting on existing doors by Underwriters Laboratories for use on fire doors having up to a three-hour rating. U.L. Certification: "Accessories for Single-point Locks and Latches and Fire Exit Hardware." Evaluated in accordance with UL 10B and UL 10C. U.L. Listing: "Electrically Controlled Single-point Locks and Latches." Evaluated in accordance with UL 10B and UL 10C. Also certified in accordance with CAN/ULC-S104.
<i>Electronics</i>	FCC Part 15 Class A and CE directive 1999/5/EC compliant
<i>Environmental Operating Conditions</i>	-31°F to 151°F (-35°C to 66°C), 0% to 85% non-condensing humidity at 86°F (30°C)
<i>Florida Building Code</i>	Approved in the exterior door category (exterior door components). Code of approval is FL13061.

## Warranty

<i>Standard Factory</i>	Two years
<i>Extended Warranty</i>	Kaba Service Plans (Platinum, Gold, Silver)

Kaba Access & Data Systems Americas  
Winston-Salem NC 27105  
1-800-849-8324  
[www.kaba-adsamericas.com](http://www.kaba-adsamericas.com)

KAA1348 0316