

MT™ RFID

Electronic hotel lock



Features

- High security design
- 1" solid deadbolt (optional auto deadbolt)
- Staff monitoring - Keycard audits
- Batteries last up to 2 years
- Low battery indicator alerts staff
- Lock programming and audit records are not erased during battery replacement
- Wear resistant construction and finish
- NFC programming

Overview

The MT is a full-body electronic lock that offers RFID card reader technology to enhance guest convenience and improve operational efficiency. Ideal for retrofits, this lock works with dormakaba's access management software.

Next generation technology and mobile access

The MT RFID supports NFC, RFID, and Bluetooth® Low Energy (BLE) technology and can operate with dormakaba Mobile Access Solutions, allowing guests to use a card key or mobile access for their digital wallet, instantly turning their phone into a key.

Access control management software

The MT RFID lock is supported by dormakaba's robust Ambiance access management software that features an array of access control workflows for both guest and staff access. Optionally, choose dormakaba's Ambiance RX online access management solution for remote access giving you anytime control, from anywhere.

Applications

- Suitable for small to very large scale hotels
- Ideal for retrofit scenarios
- Access control for guest rooms, common areas as well as back-of-house

Factsheet

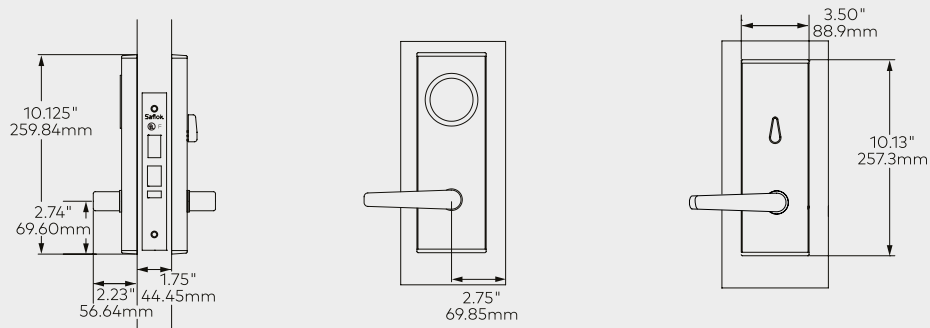

Mechanical features

Description	Electronic mortise lockset with 1" (25.4 mm) throw deadbolt and 5/8" (15.9 mm) dead-locking latch bolt
Handing	Factory-handed mortise (left, right, left reverse, right reverse)
Lever	<p>ADA Compliant:</p> <p>Continental Elevon Gala Troy</p>
Deadbolt	1" (25.4 mm) throw deadbolt and 5/8" (15.9 mm) dead-locking latch bolt
Door thickness	1 3/4" (44.5 mm) to 2 1/8" (53.98 mm) for standard product
Weight	Approx. 8.0 lbs with hardware
Housing construction	Escutcheon, exterior: Stainless steel or brass. Interior: Zinc Levers: Brass, zinc, or stainless steel
Standard finishes	Bright chrome, bright brass, satin chrome, satin brass, dark mahogany, matte black
Standard backset	2 3/4" (69.9 mm) from door edge to lever
Locking options	ANSI lock case with 1 1/4" or 1" lock front mortise Options: automatic deadbolt, door ajar, utility
Online configurations	Lock controller board with online capability DAJ mortise (ANSI lock case) Inside escutcheon equipped with online module
Bluetooth® enabled	Bluetooth® (BLE) included standard, enabling mobile credentials. Contact your local sales consultant to upgrade at any time.
Batteries	Alkaline; Four AA battery pack; Battery life is up to 2 years; low battery indicator: alerts staff that batteries need to be changed soon

Lock operation

Date/time stamp	Real-time; date and hours/minutes
Interrogation	Obtain key usage reports from the lock by using a handheld unit at the door, or increase efficiency by performing a remote interrogation using the online feature of the Access Management Software (optional)
Pre-registered keycards	Keys can be made up to ten days in advance without cancelling current or arriving guests
Keycard expiration	Configurable expiration dates; can be automatically set for check out date or manually applied when making key during check in process
Passage mode	Set by authorized keycard or access management system. Can also be configured to perform an automated/pre-defined passage mode time
Lockout mode	Set by authorized keycard or access management system
Credentials	Supports MIFARE Ultralight® C, *MIFARE Plus® EV2, and MIFARE® DESFire® EV3 credentials *MIFARE Plus® EV2: When used in enhanced security mode available in Ambiance v2.10+ Available in keycards, key fobs and wristbands
Feedback	Light indicators in reader
Diagnostics	Light indicators and handheld display
Audit trail	Up to 4,000 events
Disability feature	RCU readers interface with automatic power operated doors for special openings
Privacy override	Emergency keycards

Certifications & testing

Accessibility standard	Complies with 2010 ADA Standards for Accessible Design – Art. 309.4 (Operable Parts). For models with ASM mortise only, for application interior and exterior. Non ADA compliant with auto dead bolt. Lock shall be properly aligned with the mortise or latch and must be installed strictly according to the dormakaba installation instructions and the ADA Standards and Regulations applicable for each facility, to be able to fulfill compliance with ADA requirements.
BHMA/ANSI	Certified A156.13 Grade 1 "American National Standard for Mortise Locks and Latches"; and ANSI/BHMA A156.25 "American National Standard for Electrified Locking Devices."
Fire rating	Meets UL 10C and ULC S-104, on fire door rated up to and including 3 hours with dormakaba ANSI mortise lock case.
Electronics	MT RFID: FCC Part 15 Class A and CE Directive 2014/53/EU compliant
Environmental operating conditions	<ul style="list-style-type: none">Indoor side: 32°F to 151°F (0°C to 66°C)Outdoor side: -31°F to 151°F (-35°C to 66°C)0% to 85% non-condensing humidity at 86°F (30°C)
Florida building code	Approved in the exterior door category (exterior door components). Code of approval is FL13061.
European standard	EN179: Emergency exit device operated by a lever handle or push pad, for use on escape routes" with approved levers, and EN14846 "Electro-mechanically operated locks and striking plates". Listed with ASM lock case.

Warranty

Standard factory warranty	Two years
Support programs	dormakaba Service Plans (Platinum, Gold, Silver)

Note:

The information provided on this sheet is intended for general reference only. Availability, features, and specifications may vary by region or country. For more information, please contact your local representative.

MIFARE, MIFARE Ultralight, MIFARE Plus and MIFARE DESFire are registered trademarks of NXP B.V.

The Bluetooth® word mark and logos are registered trademarks owned by Bluetooth SIG, Inc. © dormakaba 2024 Information on this sheet is intended for general use only.

dormakaba reserves the right to alter designs and specifications without notice or obligation.

Any questions? We would be happy to advise you.

Contact us at: 800.999.6213