

1340SK mullion storage kit

Installation Instructions

Tools required

Drill
Hammer drill
Drill bits: 3/16" [4.8], 3/8" [9.5]
#2 Phillips screwdriver
Center punch
Level

Parts list

1. Mounting angle
2. 1/4" [6.4] x 2-1/4" [57.2] concrete screws (x2)
3. Top fitting with cylinder
4. 5/16"-18 x 5/8" [15.9] PFHMS (x3)
5. 3/8" [9.5] x 3" [76.2] dual expansion anchors (x2)
6. Bottom fitting
7. Instructions

1 Assembling top fitting

NOTE: Install mullion storage kit away from major traffic corridors. Ideal locations include behind door, in corners or other more secluded locations.

NOTE: Mullion tube should be properly sized and installed in actual opening prior to installing mullion storage kit.

- 1.1 Assemble top fitting to mounting angle and secure top fitting assembly with three 5/16"-18 x 5/8" [15.9] Phillips flat head screws.

2 Preparing installation area

- 2.1 Remove existing mullion from opening.

3 Marking hole locations

NOTE: Follow installation protocol to ensure proper clearance from wall.

NOTE: Use a level to ensure mullion tube is square and plumb.

- 3.1 Slide mullion over bottom fitting.
- 3.2 Insert top fitting assembly into top of mullion tube.
- 3.3 Position mullion assembly against wall in desired location.
- 3.4 Mark two top hole locations for top fitting assembly onto wall using mounting angle as a template.
- 3.5 Trace bottom fitting onto floor using bottom fitting as a template.
- 3.6 Remove mullion assembly, place bottom fitting in traced location, and use it as a template to mark two bottom hole locations.

4 Drilling holes

NOTE: Use a hammer drill and appropriate drill bit for masonry or concrete.

- 4.1 Drill two 3/16" [4.8] dia. holes into wall, 2" [50.8] deep, for top fitting assembly, where marked.
- 4.2 Drill two 3/8" [9.5] dia. holes into floor, 3-1/4" [82.6] deep, for bottom fitting, where marked.

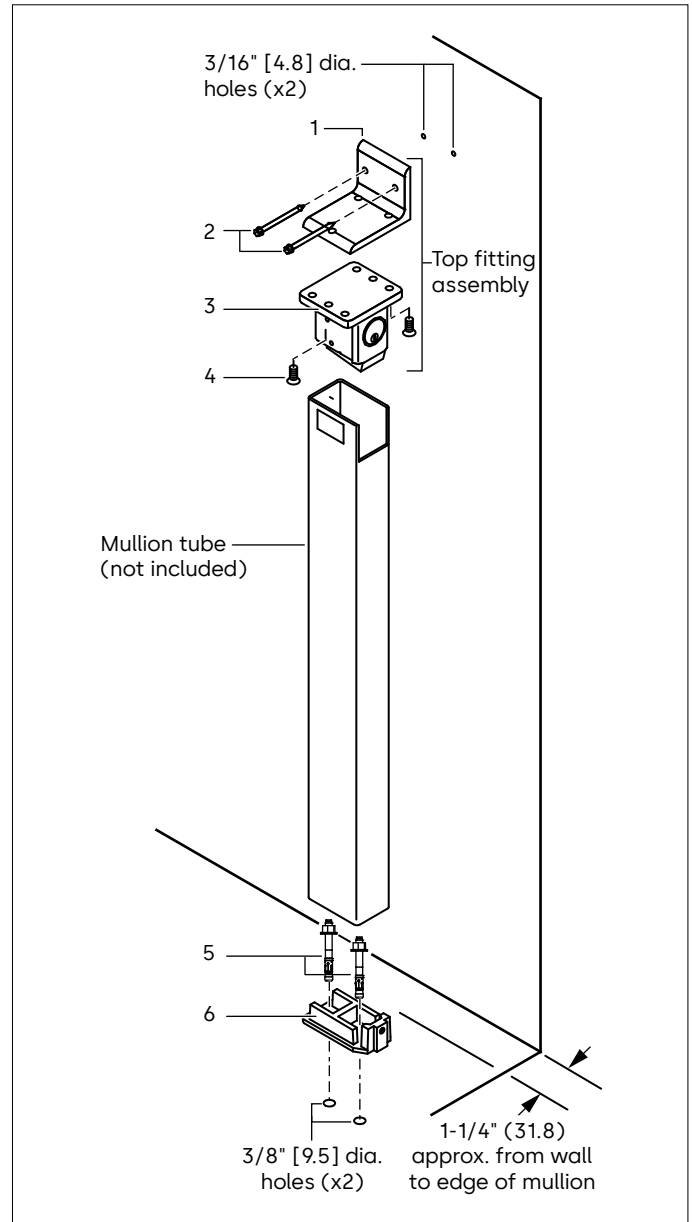

5 Installing bottom fitting

- 5.1 Install two 3/8" [9.5] x 3" [76.2] dual expansion anchors into pre-drilled holes in floor for bottom fitting.

6 Installing top fitting

- 6.1 Install two 1/4" [6.4] x 2-1/4" [57.2] concrete screws into pre-drilled holes in wall for top fitting assembly.

7 Installing mullion

- 7.1 Slide mullion tube over bottom fitting, tilt up and lock into place.

NOTE: Rotate key clockwise to remove and place mullion tube.



Document translations available.
 Scan for product details and downloads.
 Call 1-800-392-5209 or visit
<https://dhwsupport.dormakaba.com/hc/en-us>
 for assistance or warranty information.