



Solenoid Drop Bolt with manual Key Override DB25K

Operating Manual

WN 60425 45532/16458 - 08/2022

EN

Table of contents

1	Information about this document	3
1.1	Contents and purpose	3
1.2	Target group	3
1.3	Retain document	3
2	Security	4
2.1	Intended use	4
2.2	Non-intended use	4
2.3	Responsibility of the operator	4
2.4	For qualified personnel only	4
3	Product description	5
3.1	View	5
3.2	Accessories (to be ordered separately)	5
3.3	Variants	6
3.4	Technical data	6
3.5	Dimensions	7
4	Operating modes and functions	8
4.1	Overview of functions	8
5	Mounting	10
5.1	Requirements for mounting	10
5.2	Example 1: Installing lock and strike plate in mortise openings	12
5.3	Example 2: Install lock on frame and strike plate on glass door.	13
6	Electrical connection	14
6.1	Select power supply	14
6.2	Connections	14
6.3	Three-wire connection (recommended)	15
6.4	Two-wire connection	15
6.5	Connect signaling contacts for door position and bolt position.	16
6.6	Configure lock	16
7	Maintenance and Cleaning	17
8	Disposal of the device	18

1 Information about this document

1.1 Contents and purpose

This manual describes installation, connection, operation and maintenance of the lock DB25K. Read the manual carefully and observe the instructions it contains. They contain important information for reliable installation and trouble-free operation.

1.2 Target group

Target group: of these instructions are:

- Installer
- Service technician

Installers and service technicians are skilled personnel who have the specialist knowledge required for installation, commissioning and maintenance.

1.3 Retain document

This document and the applicable documents must be handed over to the operator after commissioning. The operator must keep the documents for the entire duration of operation and make them accessible to the persons responsible for inspection and maintenance.

2 Security

2.1 Intended use

- Electromagnetically operated deadbolt lock for commercial or private doors
- Installation in mortise opening or surface mounting (with accessories)
- Suitable for wooden, aluminum or steel doors/frames
- Installation indoors or in protected outdoor areas

2.2 Non-intended use

This lock is not suitable for:

- the use in escape and rescue routes,
- use in sensitive applications, e.g. fire, high security, safety or emergency exit doors
- use with accessories other than those specified
- installation in areas with humid or aggressive atmosphere (e.g. saunas, swimming pools)
- installation positions other than specified.

2.3 Responsibility of the operator

The operator is responsible for the proper condition of the installed components and their maintenance by qualified personnel.

It is the operator's responsibility to:

- To ensure that the lock is installed, connected and commissioned in accordance with these instructions;
- to determine the suitability of this lock for the intended application,
- to inspect, clean and maintain this lock on a regular basis,
- replace this lock at the end of its useful life,
- not to modify this lock,
- not to use this lock other than as intended by the manufacturer.

2.4 For qualified personnel only



DANGER

Danger due to improper mounting and connection!

In case of non-professional assembly or connection, serious injuries, fire or material damage may result from the system.

- Assembly and connection may only be carried out by persons who have the required qualifications.
-

3 Product description

3.1 View

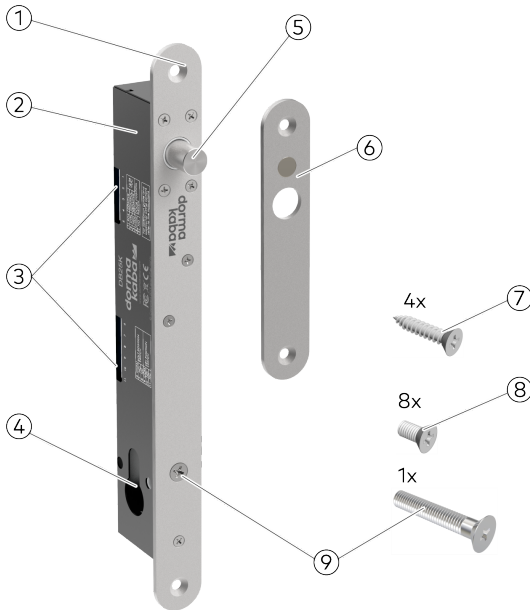

Fig. 1: View

- 1 Faceplate
- 2 Housing
- 3 Connection terminals
- 4 Space for profile cylinder
- 5 Latch
- 6 Strike plate
- 7 Mounting screws, self-tapping, 10G x 1" csk
- 8 Screws M5 x 10
- 9 Screws M5 x 30 csk

3.2 Accessories (to be ordered separately)

- Short striking plate DBA143A 2400001218
- Long striking plate DBA143E 2400001219
- Housing DBA144J 2400001221
- Housing DBA145J 2400001222
- Cover plate DBA 146J 2400001220

3.3 Variants

Fail-safe (currentless opening)

- DB25K Fail safe 2400001203

In the event of a power failure, the lock opens. This prevents people who are inside the secured area from becoming trapped in the event of an emergency.

Fail-secure (closing without power supply)

- DB25K Fail secure 2400001204

If the power supply fails, the lock closes. This ensures that the secured area remains locked if the power supply fails. This prevents unauthorized persons from gaining access by manipulating the power supply.

3.4 Technical data

Materials		
Bolt	Stainless steel SS304 Ø 12.7 mm Extension, 12 mm	
Lock, strike plate	Stainless steel SS304 Thickness 3 mm	
Mechanical		
Gap dimension	max. 6 mm	
Power supply		
Supply voltage	DC 12-24 V ±15 % SELV	(UL/IEC/EN 62368)
Protection class	III	(HD 60384-4-41)
Current consumption standby	160 mA (12 V)	95 mA (24 V)
Current consumption during operation	1250 mA (12 V)	1000 mA (24 V)
Electrical connection		
Connection terminals	Screw terminals	
Conductor cross-section	0,20 ... 2.0 mm ² /AWG24 ... AWG14	
Signal contacts		
Latch position	max. 25 V DC	max. 500 mA
Door position	max. 100 V DC	max. 500 mA

3.5 Dimensions

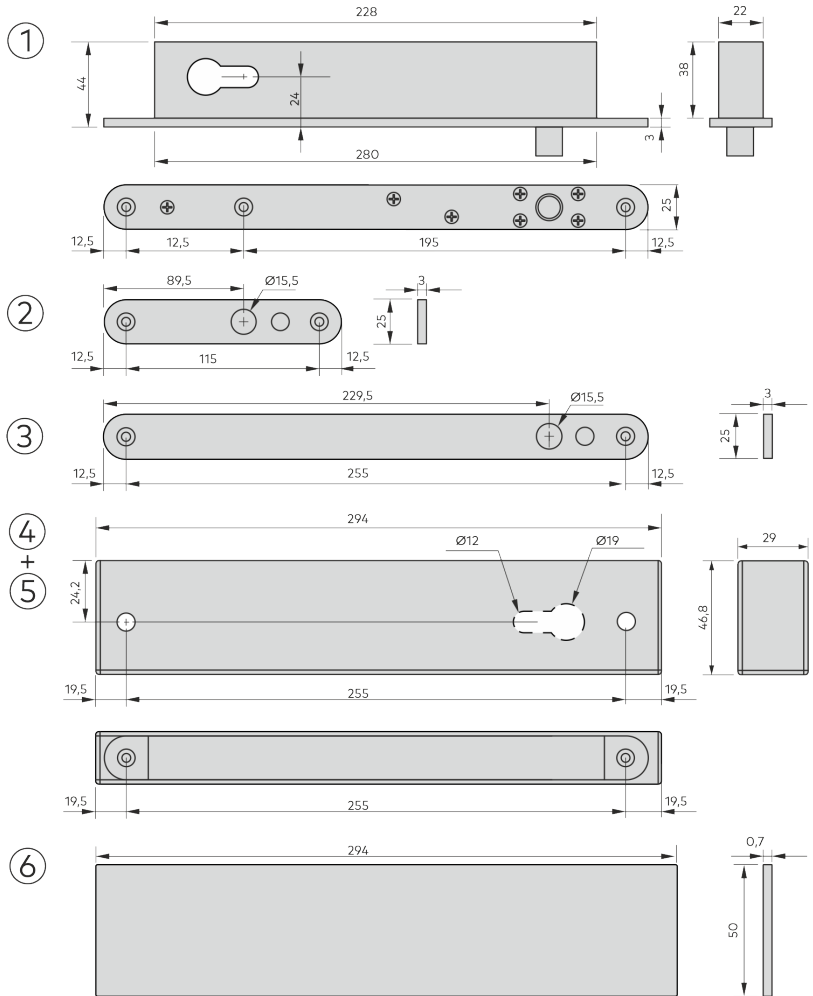

Fig. 2: Lock - dimensions

- | | | | |
|---|--|---|---|
| 1 | Dimensions lock | 4 | Dimensions latch housing (accessories) |
| 2 | Dimensions short striking plate | 5 | Dimensions of striker housing (accessories) |
| 3 | Dimensions long striking plate (accessories) | 6 | Dimensions cover plate (accessories) |

4 Operating modes and functions

4.1 Overview of functions

The DB25K is a magnetically operated deadbolt lock for single-closing doors. The intelligent electronics provide a range of functions:

Features

- Multi-voltage input (DC 12 V/24 V)
- Multiple locking/unlocking attempts
- Timed relocking
- Optimized energy consumption (standby)
- Monitoring of door position and bolt position
- High mechanical strength

Profile cylinder

The DB25K allows the inclusion of a profile cylinder. The profile cylinder allows the lock to be closed manually with the use of a key. The electronic access control is thus bypassed. Depending on the variant (fail-safe or fail-secure) and the connection type, the deadbolt is moved electrically or mechanically during manual closing.

Permanent unlocking

The lock opens when triggered at the control input. If the control signal is permanently present, the lock remains unlocked for the duration of the control signal.

Short-term unlocking

If the control signal is present only briefly, the lock unlocks only briefly. If the door is not opened, the lock locks again after an adjustable time has elapsed (typically 9 seconds). This ensures that a door does not remain unsecured if it has been unlocked but not opened. The time is configured during commissioning (0, 3, 6 or 9 seconds).

The functions of the two variants normally open (fail-safe) and normally closed (fail-secure) are explained by two examples. Both have the closed and locked door as their initial state.

Function of the fail-safe variant (currentless opening)

- Brief activation of the control input unlocks the door for 9 seconds (adjustable).
- If the door has not been opened, the lock automatically locks again.
- If the door has been opened, the lock remains unlocked until the door is closed. When the door is closed, the relocking time is started.
- After the door is closed and the relocking time has elapsed, the lock operates the bolt 9x within 15 seconds at full power.

Function Variant Fail-secure (de-energized closing)

- Brief activation of the control input unlocks the door.
- Within the next 9 seconds, the lock operates the bolt 5x within 9 seconds with full power.
- If the door has not been opened, the lock locks again within 9 seconds.

- If the door has been opened, the lock remains unlocked until the door is closed. When the door is closed, the relocking time is started.
- After the door is closed and the relocking time has elapsed, the lock latches the bolt.

Functional overview of lock and connection variants DB25K

Connection	Multiple relocking	Automatic. Re-locking	Time for relocking adjustable	Multiple unlocking
Lock variant: Fail-safe (currentless opening)				
Three-wire connection	yes (9x)	yes	yes	no
Two-wire connection	not applicable	not applicable	not applicable	not applicable
Lock variant: Fail-secure (currentless closing)				
Three-wire connection	no	yes	yes	yes (5x)
Two-wire connection	no	not applicable	no	yes (5x)

Table 1: Overview of functions

5 Mounting

5.1 Requirements for mounting

Before mounting, the following aspects must be clarified:

- Product variant
- Type of installation
- Installation position
- Cable routing and wire cross-section

Which product variant?

The product variant must match the intended use:

- For areas where people are regularly present and for which no other escape and rescue route is available, the fail-safe variant (currentless opening) should be selected.
- For areas that are to be closed in the event of a power failure, the fail-secure variant (closing without power) is suitable.

Type of installation

Optionally, the lock can be mounted on the door frame or on the door; the strike plate is installed in the door or the door frame accordingly. Installing the lock in the door frame is easier, as the cables only have to be routed through the frame. It requires more effort to lead the cables inside the door leaf to the lock.

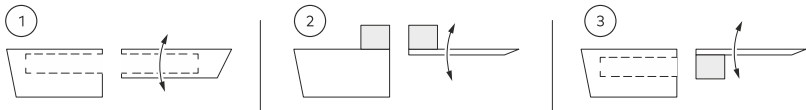

Fig. 3: Mounting variants - examples

- 1 Insertion opening in frame and door
- 2 Surface mounting on frame and door
- 3 Mortise opening in frame and surface mounting on door

A mortise opening in the door and door frame offers a discreet solution in which the lock and strike plate remain invisible. If this is not possible, e.g. with glass doors, both can be mounted on the surface using a housing (accessory). To install the striking plate in the housing, the long striking plate (accessory) is also required.

In principle, any combination of mortise opening and surface mounting can be realized, provided that the lock and strike plate are aligned with each other after mounting. When the door is closed, the gap between the lock and striking plate must not exceed 6 mm. If the gap is greater, the lock can no longer correctly detect the position of the striking plate and will no longer function reliably.

Installation position

The lock can be mounted horizontally or vertically.



When installed in the floor, penetrating moisture or similar can contaminate the mechanics of the lock and render the lock unusable in the long term.

Cable routing and conductor cross-section

The routing and thus the length of the connecting cable must be determined.

Three connecting wires are required for a fully functional lock. Connection to only two connecting wires is possible in principle; however, the full functionality is then not available. For details, see chapter Three-wire connection (recommended).

Eight connection terminals are used to connect the feedback contacts, e.g. to an access control or alarm system. The conductor cross-section for the signal lines must be selected according to the connected signaling device.

When selecting the connection line for the supply voltage, the voltage drop on the line must be taken into account! Depending on the length of the connection line, the conductor cross-section must be selected accordingly.

Conductor cross-section		Maximum cable length	
(mm ²)	AWG	at DC 12 V	at DC 24 V
0,20	24	10 m	30 m
0,33	22	16 m	48 m
0,52	20	26 m	77 m
0,82	18	41 m	122 m
1,31	16	65 m	195 m
2,08	14	103 m	310 m

Table 2: Conductor cross-section as a function of the cable length

5.2 Example 1: Installing lock and strike plate in mortise openings

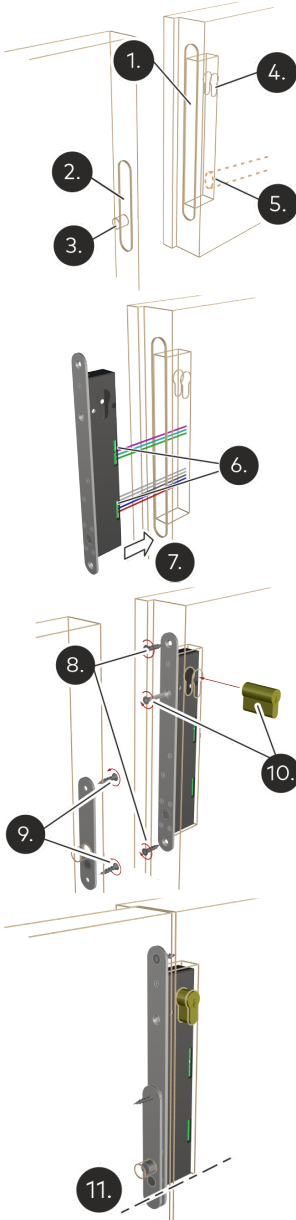

The installation example describes the installation

- of the lock into an insertion opening in the frame,
- of the strike plate into an insertion opening in the door.

1. Cut an insertion opening for the lock in the door frame.
2. Cut an insertion opening for the strike plate in the door leaf.
3. Drill holes in the door leaf to accept the deadbolt and magnetic latch.
4. Drill a hole in the back of the insertion opening for the lock and lead the connecting cable into it.
5. Connect the lock to the connecting cable. See chapter Electrical connection.
6. Push the lock into the door frame. Do not squeeze the connecting cable.
7. Fasten the lock with two 10G×1" screws.
8. Install the strike plate into the door panel and secure with two 10G×1" screws.
9. Check the alignment of the lock and strike plate with each other. The magnet function should catch and align the door so that the striker bolt can freely retract into the strike plate.

5.3 Example 2: Install lock on frame and strike plate on glass door.

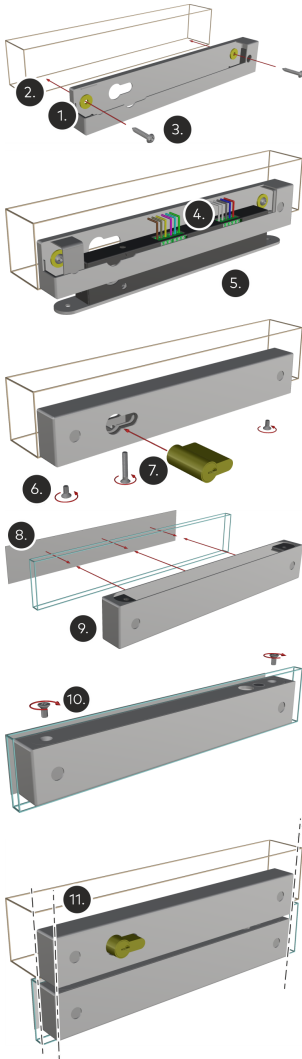

The installation example describes the installation

- of the lock on a wooden frame,
- the strike plate on a glass door.

Two housings, a cover plate and a long strike plate are required for mounting (accessories). The housings are available with double-sided tape and have mounting points for screw holes on wood and metal doors.

1. Attach the housing to the door frame. To do this, install two 10G×1" self-tapping hex head screws in the appropriate locations (included with the enclosure). Attach the housing to the screw heads with the two keyhole cutouts and tighten the screws.
2. Drill a Ø8 mm hole in the housing wall at the position for the cable entry. To prevent the connecting cable from chafing against the drilled edge, push the supplied grommet into the drilled hole. Then guide the connecting cable into the housing.
3. Connect the lock to the connecting cable. See chapter Electrical connection.
4. Push the lock into the housing. Do not crush the connecting cable.
5. Fasten the lock with two M5×10 screws.
6. Attach the housing for the strike plate to the glass door. To do this, remove the protective strip from the adhesive tape on the side of the housing and carefully attach the housing to the glass.
Note: To correct the position, press the housing only lightly at first.
7. For a neat finish on the opposite side of the glass door, attach the cover plate (accessory) in the same manner.
8. Insert the long striking plate into the housing on the door leaf in such a way that the bolt of the lock can enter the opening of the striking plate. Fasten the strike plate with two M5×10 screws.
9. Check the alignment of the lock and strike plate with each other. The magnet function should catch and align the door so that the striker bolt can freely retract into the strike plate. When the housing is in the correct position, press the housing firmly into place.

6 Electrical connection

6.1 Select power supply

The lock is designed for low power consumption. Only when the deadbolt is moved does a larger current flow.

1. Select the power supply according to the maximum current consumption.

Note: If several locks are connected to one power supply at the same time, the maximum current consumptions of the individual locks are added together.



⚠ WARNING

In the case of power supplies with high output power, there is a risk of fire due to high currents in the event of a short circuit!

High currents can cause severe damage due to overheating and even fire.

- In the case of power supplies with high output power, protect the connection lines to the individual locks with current limiters.

6.2 Connections

Terminal		Meaning	Remarks
1	+	Power supply	DC power supply connection, "+".
2	CL		Control input
3	-		DC power supply connection, "-".
4	C	Switch contact door position <i>(optional)</i>	Reference potential
5	NO*		Normally open contact for door position
6	C	Switch contact bolt position <i>(optional)</i>	Reference potential for bolt position
7	NO*		Normally open contact for bolt position
8	NC*		NC contact for bolt position
9	C	Switching contact key position	Reference potential for key position
10	NO*		Normally open contact for key position
11	NC*		NC contact for key position

*: NO = "normally open", normally open contact. NC = "normally closed", break contact.

Table 3: Connection terminals

For operation, the lock is connected to terminals 1, 2 and 3. If it is not possible or desired to lay three wires to the lock, the lock can also be connected with only two wires. Depending on the type of connection, additional wire jumpers may be required.

Terminals 4 to 11 are signaling contacts that can be evaluated by an access control or alarm system.

6.3 Three-wire connection (recommended)

In three-wire mode, the power supply is constantly connected to terminals + and - (terminals 1 and 3). To unlock the lock, control input **CL** (terminal 2) is supplied with voltage.

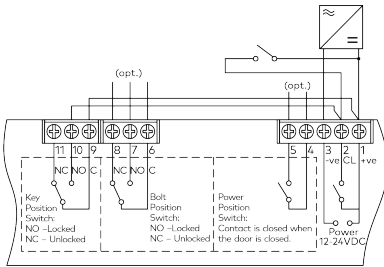

Three-wire connection at fail-safe lock

1. Connect terminals **1** and **9** with a wire jumper.
2. Connect terminals **2** and **11** with a wire jumper.
3. Connect the power supply constantly to terminals **1 (+)** and **3 (-)**.
4. Connect the control signal for the interlock to the control input **CL** (2).

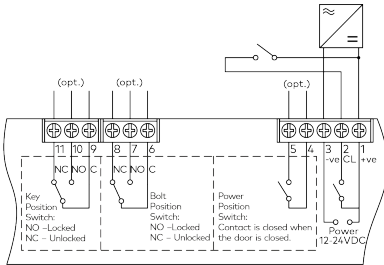

Three-wire connection at fail-secure lock

1. Connect the power supply constantly to terminals **1 (+)** and **3 (-)**.
2. Connect the control signal for the interlock to the control input **CL** (2).

6.4 Two-wire connection

In the two-wire connection, the power supply is connected to terminals +, - and **CL** (terminals 1, 2 and 3) via the external switching contact. Unlike the three-wire connection, the supply voltage is only present when the lock is to unlock.

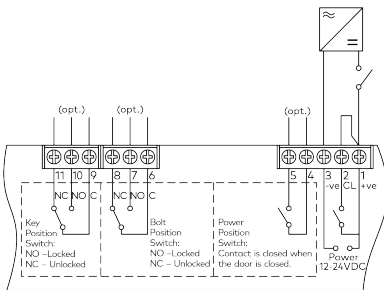

Two-wire connection at fail-safe lock

1. Connect terminals **1** and **2** with a jumper wire.
2. Connect terminal **3 (-)** to the negative terminal of the power supply.
3. Connect the terminal **1 (+)** to the switched positive pole of the power supply.

6.5 Connect signaling contacts for door position and bolt position.

The signaling contacts are used to monitor the door position, the bolt position and the profile cylinder, e.g. by an access control or alarm system. The door position is a simple normally open contact. The positions of the locking bolt and the profile cylinder are signaled by changeover contacts, so that both positive and negative logic can be used.

Connection	Message from		
	Door position	Latch position	Profile cylinder
Lock variant fail-safe (currentless opening)			
Three-wire connection	yes, normally open contact	yes, change-over contact (normally open/normally closed; NC/NO)	
Lock variant fail-secure (currentless closing)			
Three-wire connection	yes, normally open contact	yes, change-over contact (normally open/normally closed; NC/NO)	
Two-wire connection			

Table 4: Function of the signaling contacts

6.6 Configure lock

Three DIP switches S1, S2 and M are used to configure the lock. The DIP switches are accessible after removing the housing cover.

1. Open the housing cover.
2. Use the switches **S1** and **S2** to set the relocking time after which the lock automatically relocks.

Position S1	Position S2	Meaning
Off	Off	9 seconds (default)
On	Off	6 seconds
Off	On	3 seconds
On	On	0 seconds

Table 5: Switch positions S1 and S2



At DB25K the switch M is factory set for Fail Safe or Fail Secure configuration and should not be changed.

Connection	M position
Lock variant fail-safe (currentless opening)	
Three-wire connection	Off (default)
Two-wire connection	- Not applicable -
Lock variant fail-secure (currentless closing)	
Three-wire connection	On (default)
Two-wire connection	

Table 6: Switch positions M

7 Maintenance and Cleaning

The lock has been factory lubricated for life and is maintenance free. The use of other lubricants is not permitted and will void the warranty.

This lock contains electromechanical and electronic components that are subject to wear and tear depending on use and on-site installation conditions. The manufacturer has no influence on these factors. As a result of this wear, the lock may fail at the end of its normal service life.

Maintenance and cleaning

Interval	Activity
As needed:	Using a dry cloth, polish the faceplate and strike plate. Note: Look for traces of dirt and wear (dust, escaping lubricant).
Periodically, depending on frequency of use (to be determined by the operator):	Check for: <ul style="list-style-type: none"> • Tight fit • Smooth running • Noise during operation • Play of the latch • Contamination • Escaping lubricant • Moisture If there are unusual noises, noticeable play, escaping lubricant or similar, replace the lock.

Table 7: Maintaining and cleaning the lock

8 Disposal of the device



The device is marked with the symbol shown here, indicating that disposal with domestic waste is prohibited.

Old devices contain valuable recyclable materials that must be recycled. Old devices may contain substances that are harmful to humans and the environment. Correct disposal protects humans and the environment.

Owners of electrical/electronic devices are legally obliged to return them at the end of their service life to the manufacturer, the point of sale or to public collection points set up for this purpose.

- **Germany**
dormakaba Deutschland GmbH will properly dispose of goods delivered at the end of their useful life, in accordance with the legal regulations (ElektroG or the Electrical and Electronic Equipment Act in Germany). Any transport costs incurred are to be borne by the owner of the electronic device.
- **Switzerland**
The device must be taken to an electronic device collection point in accordance with VREG.
- **EU**
In the EU electronic devices must be disposed of in accordance with national disposal and environmental regulations.



www.dormakaba.com

dormakaba Deutschland
GmbH
DORMA Platz 1
58256 Ennepetal
Germany
Headquarters: +49 2333 793-0
Service DE: 0800 524 0246

www.dormakaba.com