

Installation Instructions for Flush Wall Mount Electromagnetic Door Holders Catalog Series EM 509



Description

The EM 509 Series are flush mount door holders for use with single doors. The units are UL and cUL Listed and FM approved

Installation

Install and wire in accordance with applicable codes, standards, such as NFPA publications 70 (National Electrical Code), 72 (National Fire Alarm Code), and 80 (Standard for Fire Doors and Fire Windows), and/or other regulations applicable to the country and locality of installation and in accordance with authorities having jurisdiction.

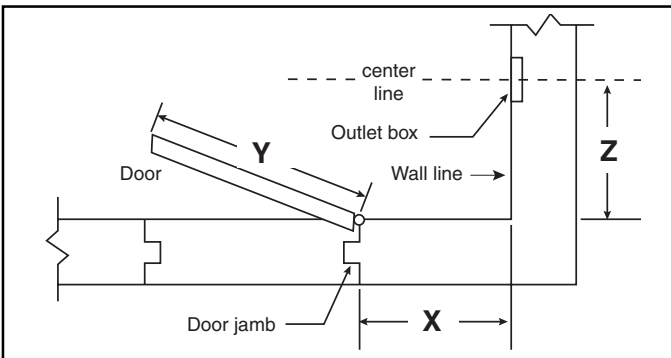

Figure 1. Locating the Door Holder

- Using Figure 1 and Table 2, locate the intersection of Dimension X and Dimension Y. Dimension Z is shown at the intersection in the gray area.

NOTE: If dimension X or Y is not shown on the chart, extrapolate Dimension Z. (i.e., if X=7, and Y=28, $Z = (27-5/8 - ((27-5/8) - 27-1/4)/2) => Z = 27-9/16"$

- Install a single gang outlet box (not supplied) on the horizontal center line and 5" from the top of the door.

NOTE: The outlet box must be able to withstand a maximum holding force of 50 pounds.

If X and Y intersect in the blank area in Table 2, DO NOT install the outlet box. The contact plate and electromagnet cannot be aligned with these dimensions.

Table 1. Specifications

Cat. No.	Volts	Amps
EM 509 24120	24V AC 60 Hz	0.015
	24V DC	0.015
	120V AC 60 Hz	0.015

Electromagnet Assembly and Cover Mounting

WARNING

To prevent electrical shock, ensure power is disconnected.

- Refer to Figure 2. Pull field wiring through conduit into the single gang outlet box.
- Establish earth-ground continuity in accordance with applicable codes, standards and authorities having jurisdiction. A green insulated lead wire is provided for this purpose.
- Refer to Figure 3 and connect as instructed below:
 - 120V AC operation.** Connect power field wiring to terminals marked "120V AC" and "COM."
 - 24V AC/DC operation.** Connect power field wiring to terminals marked "24V AC/DC" and "COM."
- Secure the electromagnet bracket assembly to the outlet box using two #6-32 x 1/2" screws provided (Figure 2).
- Mount the cover to the electromagnet bracket assembly and secure with the two #6-32 x 3/8" screws provided (Figure 2).

NOTE: The combined projection of the electromagnet assembly and armature assembly is 1 27/32".

Armature Assembly Mounting

NOTE: Armature assembly must be mounted vertically (Figure 4) to obtain correct alignment with the electromagnet.

- Using a 5/32" Allen wrench, turn the contact plate adjusting screw (Figures 5 and 6) counterclockwise to loosen the contact plate.

Table 2. Dimension chart (in inches)

		Y = Dimension of door width											
		28	30	32	34	36	38	40	42	44	46	48	
X = Dimension of door jamb to wall	2	26 (660)	28 (711)	29 7/8 (759)	32 (813)	34 (864)	36 (914)	38 (965)	40 (1016)	42 (1067)	43 7/8 (1114)	45 5/8 (1159)	
	4	26 (660)	28 (711)	29 7/8 (759)	32 (813)	34 (864)	36 (914)	38 (965)	40 (1016)	42 (1067)	43 7/8 (1114)	45 5/8 (1159)	
	6	25 5/8 (651)	27 5/8 (702)	29 5/8 (752)	31 3/4 (806)	33 3/4 (857)	35 3/4 (908)	37 3/4 (959)	39 3/4 (1010)	41 3/4 (1060)	43 5/8 (1108)	45 3/8 (1153)	
	8	25 1/4 (641)	27 1/4 (692)	29 1/4 (743)	31 3/8 (797)	33 1/2 (851)	35 1/2 (902)	37 3/8 (949)	39 1/2 (1003)	41 1/2 (1054)	43 3/8 (1102)	45 1/4 (1149)	
	10	24 5/8 (625)	26 3/4 (679)	28 3/4 (730)	30 7/8 (784)	33 (838)	35 (889)	37 (940)	39 1/8 (994)	41 1/8 (1045)	43 (1092)	44 7/8 (1140)	
	12	23 3/4 (603)	25 7/8 (657)	28 (711)	30 1/8 (765)	32 1/4 (819)	34 3/8 (873)	36 3/8 (924)	38 1/2 (978)	40 5/8 (1032)	42 1/2 (1080)	44 3/8 (1127)	
	14	23 3/4 (603)	25 (635)	27 1/4 (692)	29 3/8 (746)	31 1/2 (800)	33 3/4 (857)	35 7/8 (911)	38 (965)	40 (1016)	42 (1067)	43 7/8 (1114)	
	16	21 3/4 (552)	24 (610)	26 1/4 (667)	28 1/2 (724)	30 3/4 (781)	33 (838)	35 1/8 (892)	37 1/4 (946)	39 3/8 (1000)	41 3/8 (1051)	43 3/8 (1102)	
	18	20 (508)	22 1/2 (572)	25 (635)	27 3/8 (695)	29 3/4 (756)	32 (813)	34 1/4 (870)	36 1/2 (927)	38 5/8 (981)	40 5/8 (1032)	42 1/2 (1080)	
	20	18 1/4 (463)	21 (533)	23 1/2 (597)	26 (660)	28 1/2 (724)	30 7/8 (784)	33 1/8 (841)	35 3/8 (899)	37 5/8 (956)	39 5/8 (1006)	41 5/8 (1057)	
	22		18 3/4 (476)	21 5/8 (549)	24 3/8 (619)	27 (686)	29 3/8 (746)	31 3/4 (806)	34 1/8 (867)	36 1/2 (927)	38 5/8 (981)	40 3/4 (1035)	
	24				22 1/2 (572)	25 1/2 (648)	28 1/8 (714)	30 5/8 (778)	33 1/8 (841)	35 5/8 (905)	37 7/8 (962)	40 (1016)	
	26	Do not install outlet box if						26 1/4 (667)	29 (737)	31 5/8 (803)	34 1/4 (870)	36 1/2 (927)	38 5/8 (981)
	28	Dimensions X and Y intersect in this blank area.											
30	The armature and electromagnet cannot be aligned.												
32								27 3/4 (705)	30 5/8 (778)	33 (838)	35 3/8 (899)		
										31 3/8 (797)	33 7/8 (860)		

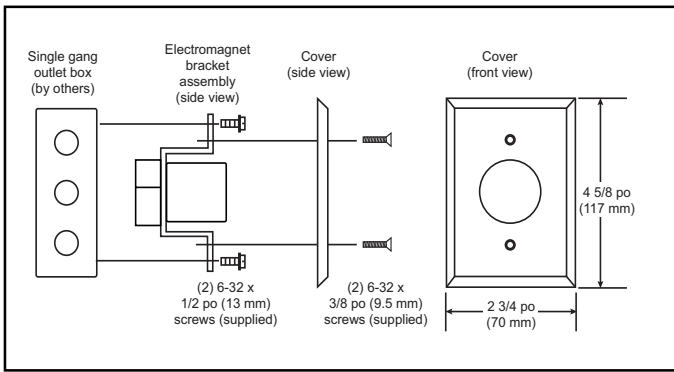

Figure 2. Mounting

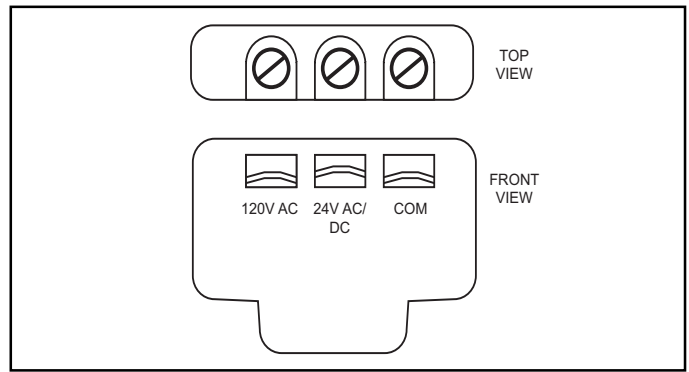

Figure 3. Terminal Block

2. Place the transfer marking points in the armature mounting holes (Figure 4).
3. To locate the two mounting holes in the door, hold the contact plate centered against the magnet, open the door and press against the transfer marking points on the armature base.

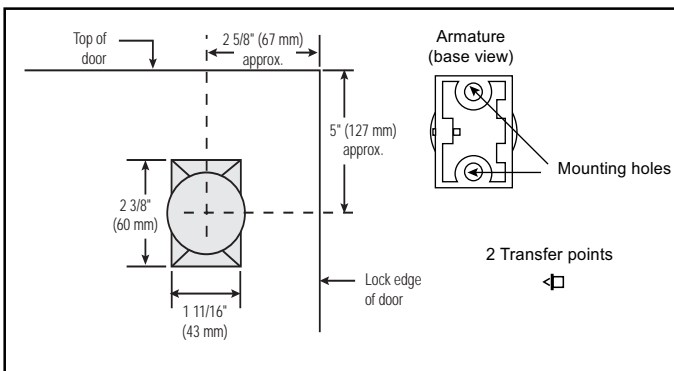

Figure 4. Mounting the Armature Assembly

Release the door and remove the transfer marking points.

4. Mount the armature assembly using one of the following methods:
 - a. **Thru-bolt mounting (Figure 5).** Center punch the two holes (at the points marked in step 3) and drill 5/16" diameter through the door. Distance between the center points should equal 1 3/4".

NOTE: Thru-bolt mounting is recommended for standard 1 3/4" hollow metal, hollow core or composite type wood doors.

Secure the armature assembly, with the contact plate adjust screw facing down, to the door as shown in Figure 5 using (2) #1/4-20 x 2" screws (supplied).

NOTE: For 2" doors, use (2) 1/4-20 x 2-1/4" bolts.

- b. **Surface concealed mounting (Figure 6).** Measure two points for 1/8" holes drilled 1/2" on center equidistant

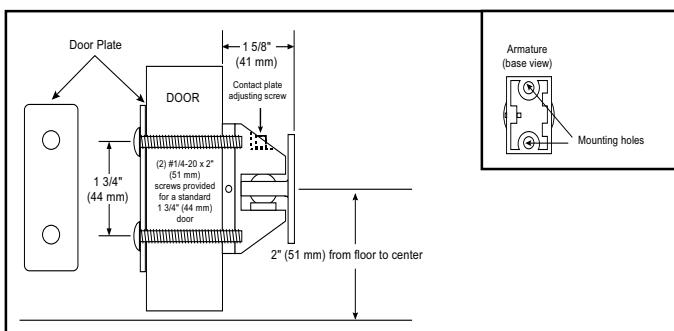

Figure 5. Thru-Bolt Mounting

from each marked point. Center punch the holes and drill 1/8" diameter x 1 1/4" deep. Install the concealed mounting plate using the two #10 x 1 1/2" screws provided.

NOTE: Surface concealed mounting is not recommended for hollow metal, hollow core, or composite type wood doors.

Align the holes for the concealed mounting plate in the armature base with the pins on the concealed mounting plate. Secure the armature assembly, with the contact plate adjust screw facing down, to the door by tightening the set screw as shown in Figure 6.

5. Align the contact plate against the electromagnet. The contact plate **must be** centered and lie flat against the magnet to ensure sufficient holding force. Tighten the contact plate adjusting screw until the plate is firm but not set. **Do not overtighten the contact plate.**
6. Recheck alignment and adjust if necessary.
7. Adjust the door closer to exert 3 pounds of force when the door is open and armature and magnet are in contact.
8. Energize the electromagnet and open the door(s). If the door shuts, check that power is turned on to the unit and that the magnet is energized and check the alignment of the contact plate and electromagnet.

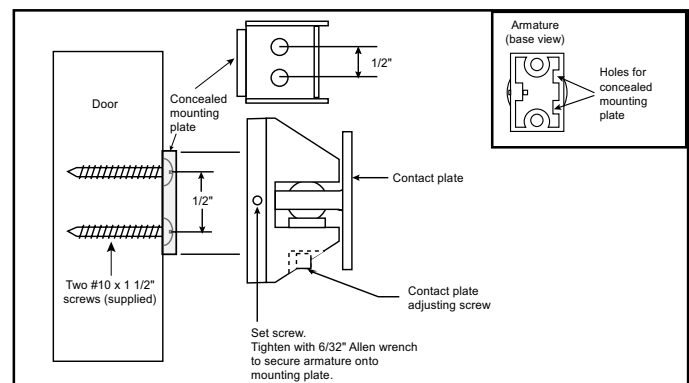

Figure 6. Surface Concealed Mounting