

Saflok Quantum™ RFID RCU/ECU

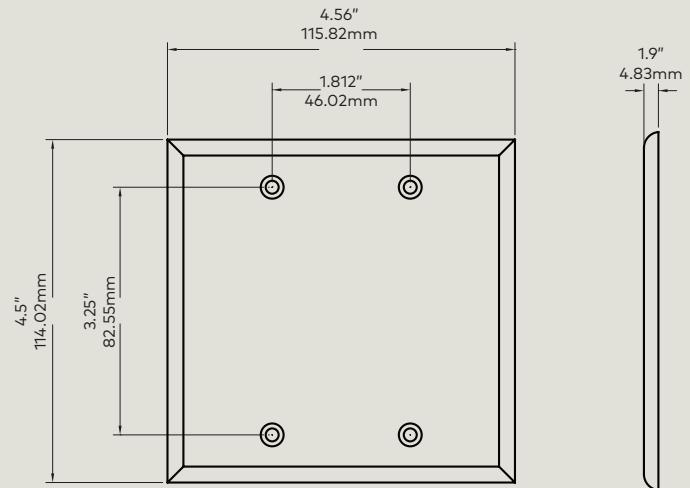

Overview

The Quantum™ RFID remote control/elevator control unit (RCU/ECU) is a versatile stand-alone card reader controller. Through the application of contactless smart card technology, this remote control device is designed to work with all electrified access control devices for perimeter doors, concierge floors, common areas, and other secured areas with electrified hardware.

Mobile Access Solutions

The reader device is able to operate using the dormakaba Mobile Access Solutions.

Applications

- RCU switch works with electrified locking devices
- Fits into double-gang switch box
- Controls electric locking devices up to 24 volts AC/DC
- Auto latch/unlatch feature eliminates need for manual dogging
- SPDT 5A@30VDC relay with common, normally open and normally closed contact

Voltage

- 12-24 AC/DC

Outside Dimensions

- 4.56" W x 4.50" H x 0.75" D

Finish Options

- Bright Brass
- Bright Chrome
- Satin Brass
- Satin Chrome
- Dark Mahogany
- Black
- Satin Nickel

Access Management Software

The Quantum RFID RCU/ECU is supported by dormakaba's robust access management software solution that features an array of access control workflows for both guest and staff access. Optionally, choose dormakaba's online access management solution for superior control and monitoring.

Features

Ability to easily integrate

Environmentally sealed contactless smart card reader protects against climate extremes, which is an especially vital feature for common access readers placed in external building and exit device applications

Optionally equipped with the online transceiver for centralized access control

LED lights displayed behind high-impact polycarbonate reader lens

Contactless smart card reader uses industry-standard Mifare ISO 14443A communication platform and high-security protocol

USB connectivity to LPI probe

Keycards are programmed using a contactless encoder

Contactless communication between the keycard and the reader via RF waves

Programmable auto latch/unlatch feature eliminates need for manual dogging

Configurable for normally closed circuits (magnet latches) and normally open circuits (electric strikes)

Auditable entries/attempts

Selectable master key access

Restricts access to guest keys after check-out date

Specifications

Voltage: 12-24 VAC or VDC

SPDT 5A@30VDC relay with common, normally open and normally closed contacts

Requirements

Double-gang switch box

Mobile access options

BLE ready: upgradable to BLE by BLE module

BLE enable: end cap with BLE module included, no further upgrades need



© dormakaba Canada Inc. (2021). Information on this sheet is intended for general use only. dormakaba Canada reserves the right to alter designs and specifications without notice or obligation. Printed in Canada.

dormakaba USA Inc.
6161 E. 75th St.
Indianapolis, IN 46250

1 800 999 2613

www.dormakaba.us

M3579_06_21