

# ädesē™ (Odyssey™) Installation Instructions

All parts needed to install the ädesē™ lock are included with each unit. Please check to make sure all parts are accounted for before beginning installation. Do not substitute any of the parts. The use of substitute parts will result in poor performance of the lock.

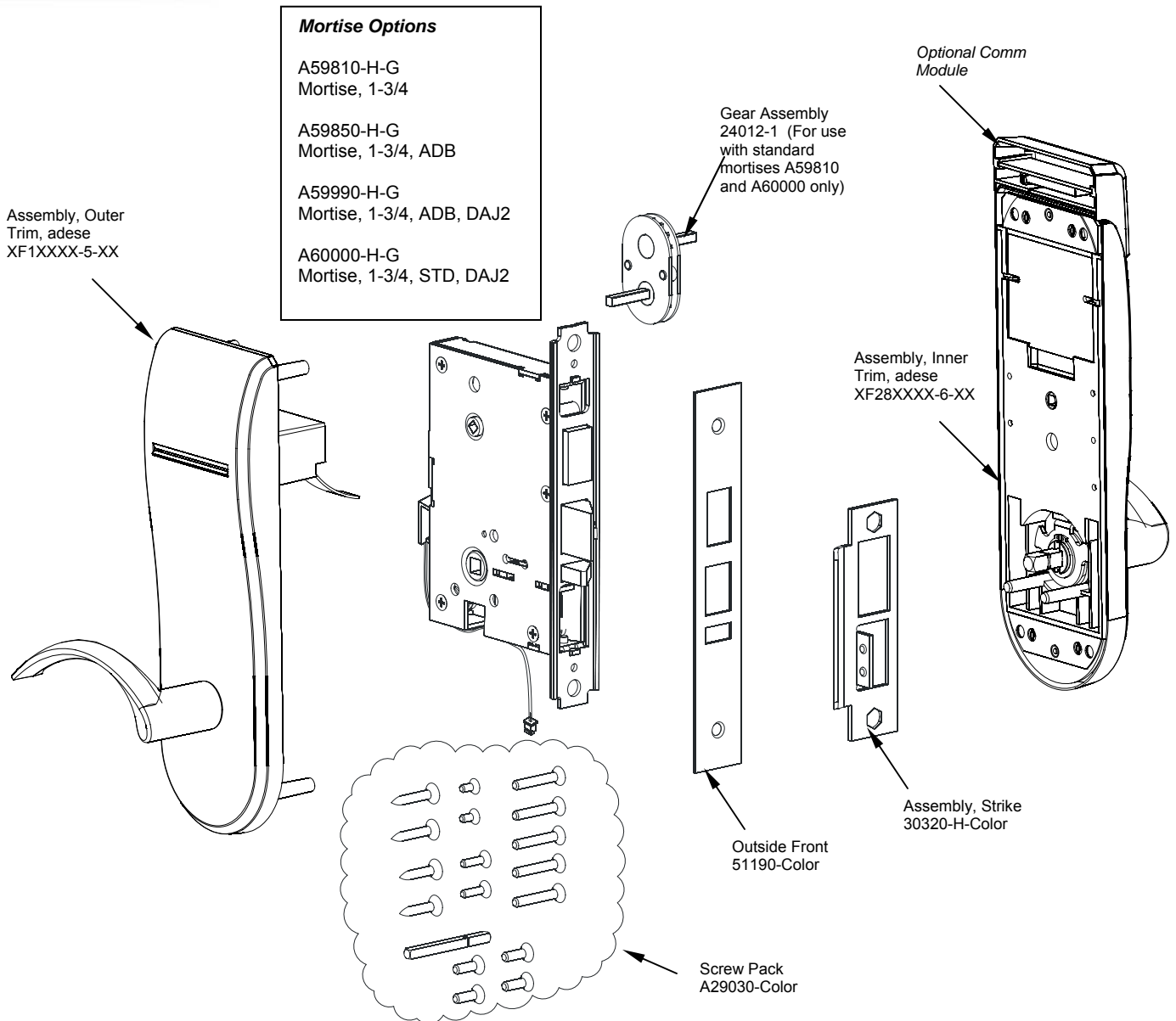

All information contained herein, including but not limited to product pricing and other intellectual property, is confidential and intended for the sole use of the addressee(s) so named. Any misuse of this confidential information contained herein may result in legal action by Computerized Security Systems dba SAFLOK and its parent company.

## Preparing the door and door frame

1. Prepare the door using the Odyssey installation template or drill fixture. The door edge prep is a standard, full-mortise prep for a 1-1/4" x 8" front plate (1" x 8" and 1" x 7-3/4" custom front plates are optional). The door surface holes and mortise are customized for the SAFLOK trim.

**Important:** Some holes are only on the inside surface of the door.

- For new construction installations, the door manufacturer may prepare the door using the installation template.
- For retrofit installations, remove the existing hardware and confirm that the existing door edge prep is appropriate for the SAFLOK mortise lock.

**Drill fixture:** If you are using a SAFLOK drill fixture (shown in Fig. 1), position and clamp the fixture on the door. The fixture has two positioning posts that rest inside the mortise, establishing the proper backset for the trim. When the fixture is clamped, its surfaces should be parallel with the door surfaces and door edges. Not all holes go through the door (refer to the template). Remove the fixture and complete the rectangular cutout by sawing or grinding between the four holes. Also, notch the material on the inside surface for easier routing of the motor wire. After machining, remove any debris from the mortise and cutouts.

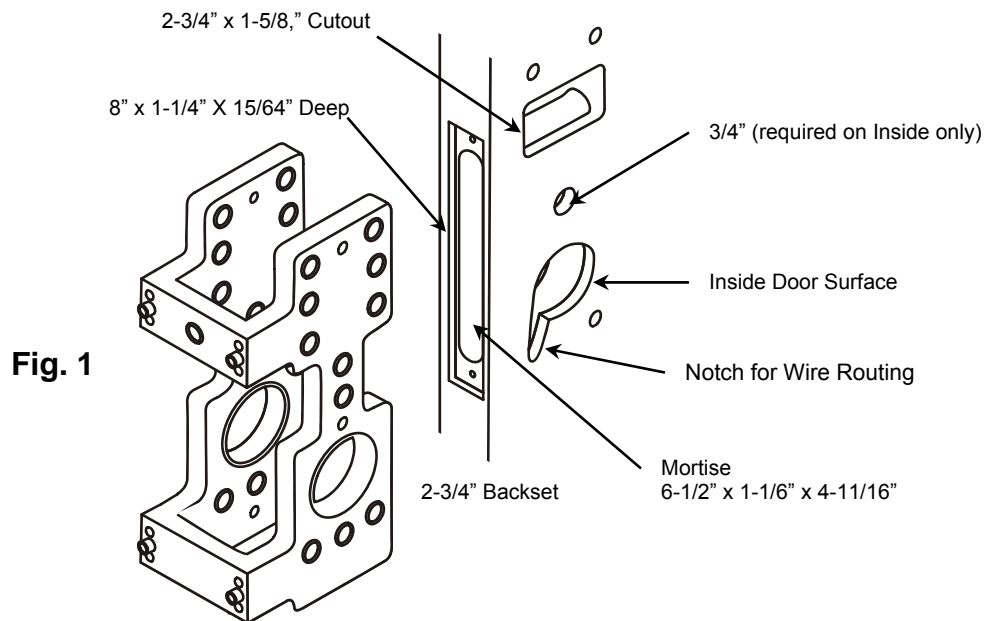

**Preparing the door and door frame (continued)**

2. Prepare the door frame using the template and install the strike plate using the screws provided (12 x 1-1/2 screws for wood frames, 12-24 x 3/8 screws for metal frames).
3. The mortise plate has an adjustable bevel. Align the mortise front plate with the bevel of the door edge and tighten the two bevel adjustment screws at the top and bottom of the mortise case. Position the mortise case in the door edge with the motor wire routed through the notch (see Fig. 2).

**Note:** Use care to ensure that the wires do not get pinched or pulled as the mortise is inserted into the pocket.

4. Attach the mortise front plate to the door using the two mortise screws (12 x 1-1/4 screws for wood doors, 12-24 x 3/8 screws for metal doors). Be sure that the screws are fully tightened.

**Important:** DO NOT leave the screws loose. The screws must be fully tightened before the trim is installed. If you must leave the mortise loose to install the trim, the door preparation is incorrect.

5. Install the scalp plate with the 8-32 x 1/4 screws provided and test for proper mechanical latch engagement into the strike plate.

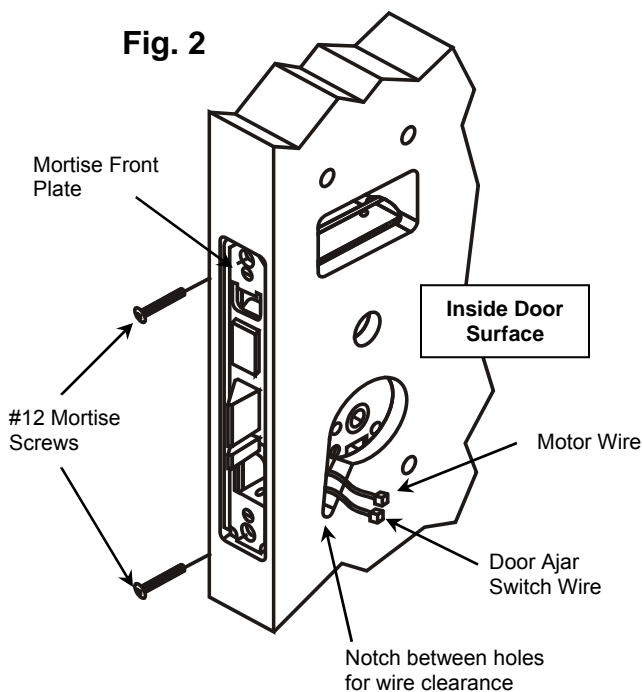

## Installing the lock trim

Both the outside and inside trim assemblies have 1/4" alignment pins that fit into holes in the mortise case. These pins establish an accurate trim position with respect to the mortise case assembly, allowing the levers and bolt mechanism to operate freely without binding. The holes machined in the door surfaces should not influence the trim's position.

There should be clearance between the features of the outside trim and the door prep holes. If the outside trim fits tightly because the through bolt posts or card reader enclosure rubs on the door prep holes, then remove the mortise and enlarge the holes to achieve a free fit. Under no circumstances should the 1/4" alignment pins be bent or removed to allow a free fit (see Fig. 3).

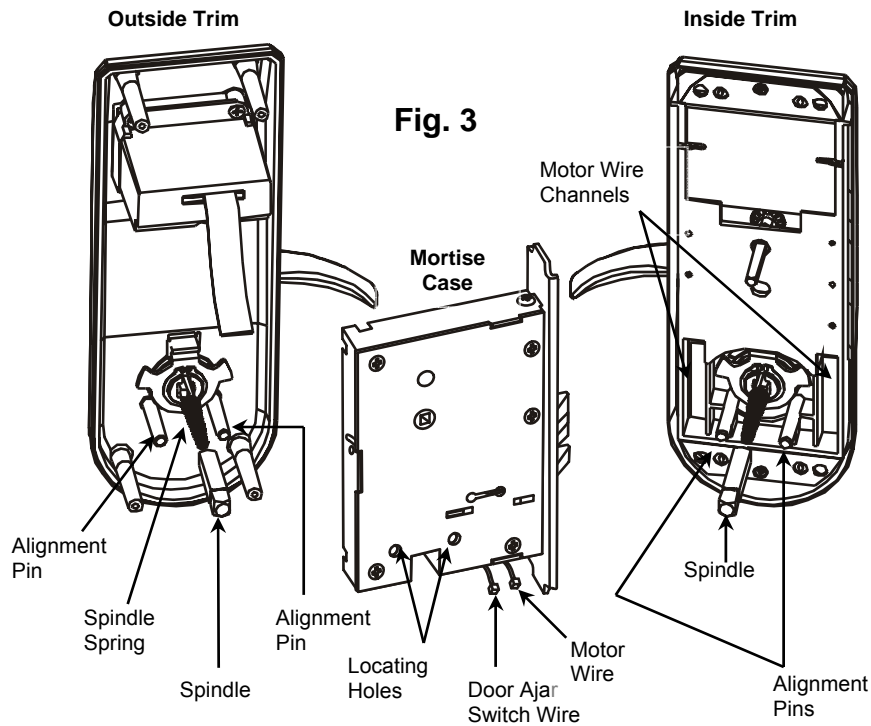

<b>CE</b>	dormakaba Austria GmbH Ulrich-Bremi-Straße 2 3130 Herzogenburg Österreich
0432-CPR-00072-03	19
EN 14846: 2008	3 / S / 5 / D / 0 / G / 3 / 0 / 3
ESM MORTISE	DOP_0175

<b>CE</b>	dormakaba Austria GmbH Ulrich-Bremi-Straße 2 3130 Herzogenburg Österreich
0432-CPR-00072-03	19
EN 14846: 2008	3 / S / 5 / D / 0 / G / 3 / 0 / 3
ASM MORTISE	DOP_0175

## Installing the lock trim (continued)

1. Position the outside trim on the door with the card reader ribbon cable passing through the rectangular cutout. Use a care so the ribbon cable does not get pulled or cut. On metal doors, it may be necessary to deburr the inside rectangular hole or insulate the bottom edge of the rectangular hole with a piece of tape (see Fig. 4).

**Note:** SAFLOK spacer plates will be required for doors less than 1-3/4" thick.

2. Route the ribbon cable through the rectangular hole in the inside trim. This hole is located above printed circuit board (PCB) assembly. Route the mortise wires through the wire channel in the inside trim closest to the door edge. These holes are located below the PCB (see Fig. 5). Position the back plate onto the door surface with the alignment pins inserted into the mortise case holes. Check for a free fit and ensure the back plate is resting flat on the door without pinching the mortise wires wire.

3. Install four M5 flathead screws and tighten. When using a power screwdriver, use caution to avoid cross threading and over torquing (see Fig. 6).

4. Insert the ribbon cable into the ribbon connector on the PCB as shown in Fig. 6.

5. Connect the motor wire, the door ajar switch wire, then connect the battery wire (if not factory attached) to the PCB as shown (see Fig. 6).

**Important:** The battery wire should be the last connection made to the PCB.

7. With the deadbolt retracted, insert the long end of the deadbolt spindle assembly through the PCB switch cam hole and into the mortise deadbolt hub. The indicator marks on the switch cam should be at the right when the mortise deadbolt is retracted (see Fig. 6). The retaining ring should rest on the switch cam when fully inserted.

**Note:** Proper positioning of the cam will allow the door to be opened when the deadbolt is retracted and block entry when the deadbolt is thrown for privacy. Emergency keys will override this electronic double lock.

8. Install the inside escutcheon with the deadbolt thumb-turn pointed up. Fasten with two flathead M4 Torx screws provided (see Fig. 7).

9. Program the lock using the Lock Programmer & Interrogator (LPI) probe provided with the key encoding system. After programming the lock, test for proper function using appropriate keys per the instructions in the programming manual.

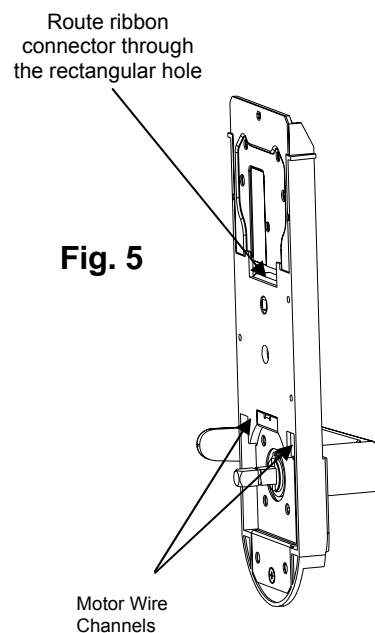
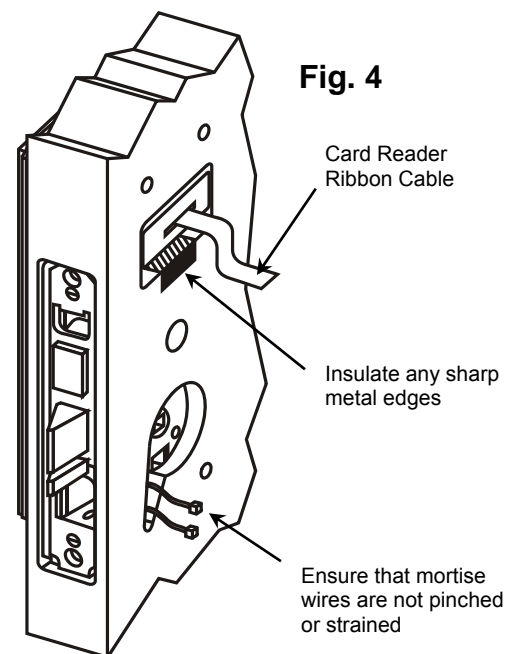

### Installing the lock trim (continued)

Fig. 6

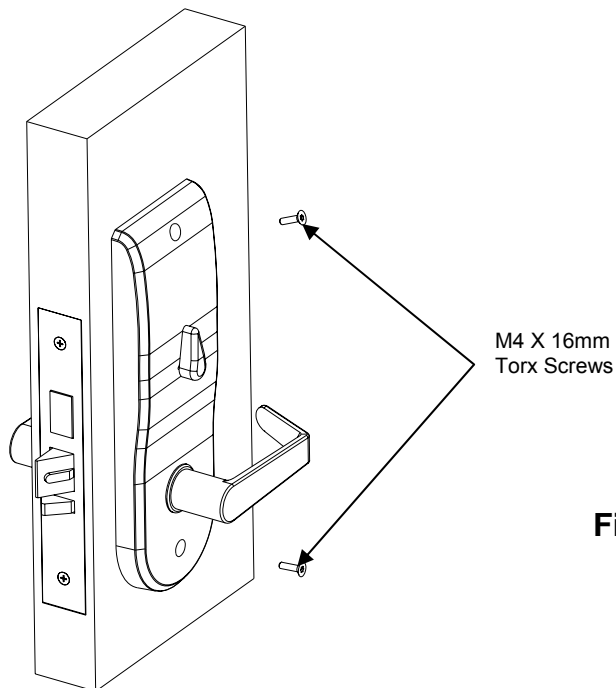
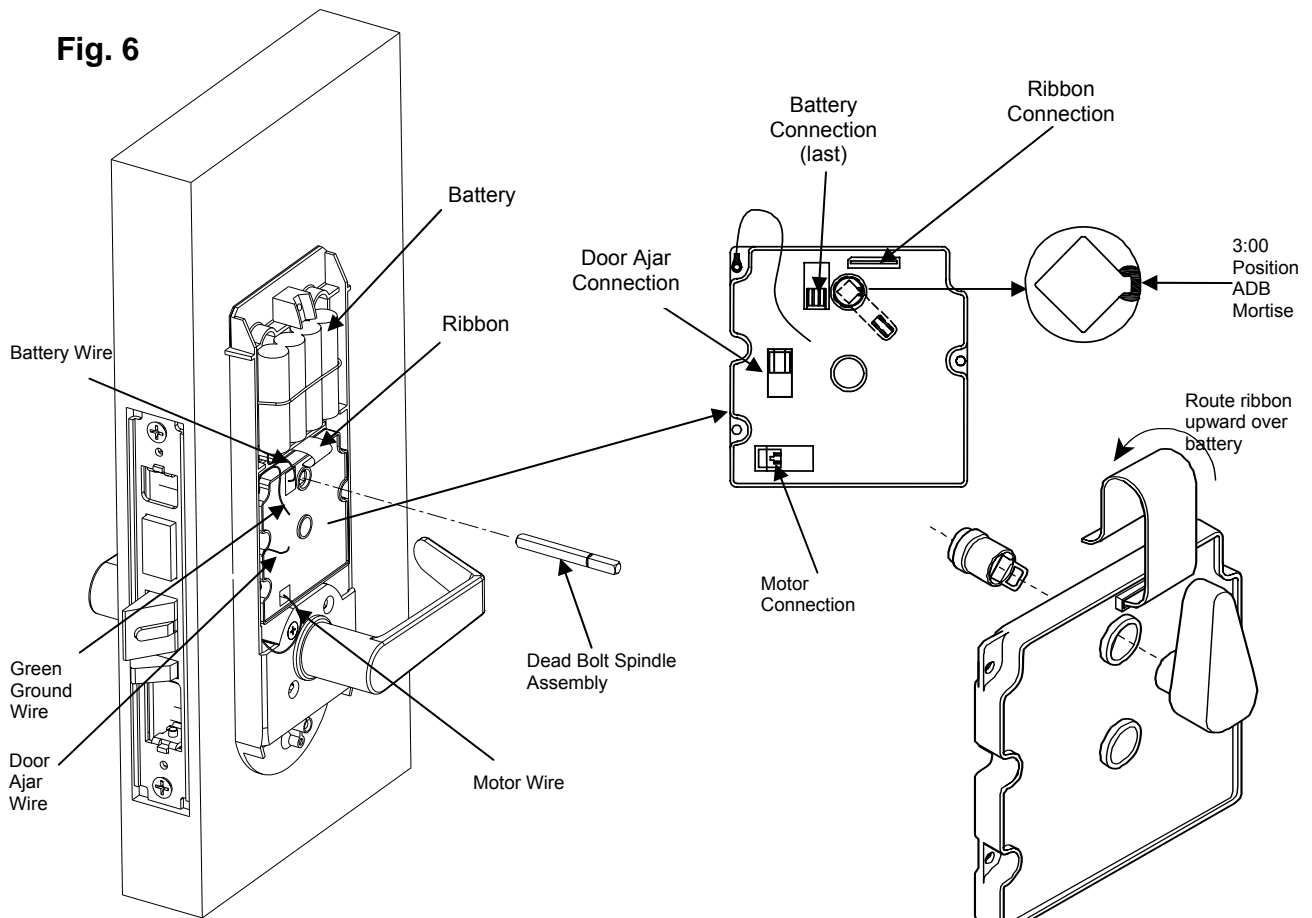

Fig. 7

**Testing Lock Functionality**

Insert a Construction keycard in the keycard reader. Be sure that the green light flashes for five seconds while the exterior lever remains operable. If the green light does not flash, refer to the table below.

<b>Lock Communication</b>	<b>Electronic Function Description</b>
<b>12 Yellow blinking lights</b>	Switch cam not aligned properly
<b>Two Yellow blinking lights</b>	Keycard not allowed OR Keycard cancelled out by newer construction level keycard
<b>Nine Red blinking lights and alternating Red and Green lights</b>	Low battery condition - contact SAFLOK Service Department
<b>Two Yellow and Red simultaneously blinking lights</b>	Bad track read or keycard data corrupted and may require a new access card
<b>Nine simultaneous Red and Green blinking LEDs</b>	Date not set - use LPI to reset date and time
<b>Two Red and Yellow blinking lights</b>	Keycard not read (upside down, wrong end, wrong key?)

## SAFLOK Door Unit Inspection Criteria

### Appearance

- Finish is free of blemishes or scratches that would distract from lock appearance
- Lock body and under plate (if used) are mounted straight on the door
- Door scalp is mounted straight and flush with the door edge
- Jamb strike is mounted straight and is flush with the jamb face
- Correction of minor blemishes on the door jamb are the responsibility of the property's maintenance department

### Lock Function

- Knob or lever rotates and moves freely
- Lever is horizontal to floor when at rest position
- Dead bolt extends fully and retracts without binding (door open)
- Lock latch and dead bolt engage jamb strike plate freely
- Anti-pick latch when depressed (door open)
- Anti-pick latch is depressed when contact is made with the strike plate (door closed)

### Electronics/Keycards

- Keycard can be inserted and withdrawn freely
- Yellow light flashes twice when incorrect keycard is used
- Red and yellow lights flash twice if keycard is used incorrectly and cannot be read (e.g., a credit card is used)
- Green light flashes when the proper keycard is used
- Green light is flashing when the lever is operated
- Green light continues to flash for a five-second cycle
- Yellow light flashes 12 times when the dead bolt is extended and a guest/hotel keycard is used
- All keycards function to the specifications of the master plan

### Door function

- Door closes and latches with little or no interference
- Dead bolt extends fully through the strike plate without interference (door closed)
- Spacing between door edge and inside door jamb does not exceed 3/16" (door closed)

**Note:** If bumpers or other seals are added after strike plate installation and causes alignment and latch problems, it is the property's responsibility to correct this condition. This note generally applies to new construction or new door installation.

**Questions?** Call Customer Service at 800.999.6213 and select option 3.  
For online assistance, visit [support.saflok.com](http://support.saflok.com).



A Member of the Kaba Group

For worldwide office locations and contact information, visit us at

[www.saflok.com](http://www.saflok.com).

#### USA·Canada

Phone: **877.272.3565**

#### Europe · Middle East · Africa

Phone: **33.1.30.13.04.04**

#### Asia

Phone: **86.10.5861.3561**

Manufactured under one or more of the following patents:

U.S.: 4,177,657; 4,411,144; 4,534,194; 4,890,870; 5,198,643;  
5,477,041; 5,820,177; 5,986,564; 7,051,561; D494,841; D501,131  
D512,899; D519,021; D531,629; D533,009; D533,047; D533,762;  
D533,763; D535,629 CANADA: 1,252,854; 1,298,902  
U.K. 2,010,375  
Other U.S. and foreign patents pending

SAFLOK reserves the right to modify the characteristics and features of all products in this publication.  
©2008 SAFLOK, all rights reserved.