

ST PRO Green

Energy-saving
automatic sliding door





ST PRO Green

Elegant and sustainable.
Safety first.

With the ST PRO Green automatic sliding door, dormakaba underlines its contribution to increased energy efficiency and sustainability.

ST PRO Green

A solution for energy efficiency	5
Profile system	6
System planning	7
ST PRO Green profile system	8
Casing variants	10
Additions sliding door system	11
Locking devices	12
Manual release	13
Technical data for sliding doors	14
Connections with CAN-bus technology	15
Technical data for sliding door operators	16
Master controller functions and optional expansion module functions	18
Door Pilot Interface	19

Wide range of accessories from dormakaba

Program switches	20
Activation switches	21
Key switch & LED touch key	22
Emergency activation buttons	23
Cover frame for buttons and switches	23
Active infrared sensor and combined sensors	24
Accessories for active infrared sensor and combined sensors	25

ST PRO Green

A solution for energy efficiency.

The ST PRO Green combines many functions – and is elegant and attractive thanks to the slim-line profiles. It therefore perfectly matches sliding doors of the dormakaba ST FLEX series.

The slim profile system can be equipped with double and triple glazing, which makes it possible to achieve particularly low U_D values.*



Powerful drive unit

Thanks to the new drive system ES PROLINE, door leaf weights of up to 400 kg can be moved particularly quickly and quietly.

The low energy demand of the sliding door drive also contributes to the positive energy balance of the door. The drive unit is suitable for almost any application area, as well as use in emergency exit doors.

Thermally separated profile

With thermal partition by the profile and the option of using triple glazing, U_D values (heat transfer coefficient) of up to 1.0 are achieved, which corresponds to the current requirements of the EnEV energy-saving regulation*.

The ST PRO Green enables significant savings of perpetual energy and heating costs and the reduction of CO₂ emissions.

* Each ST PRO Green receives individual evidence of the U_D -value



ST PRO Green – comprehensive energy efficiency.

- Thermally isolated profile system
- Ultra-low UD values of up to 1.0
(depending on the glazing used)
- 1-leaf and 2-leaf sliding doors
- For use in escape routes and emergency exits
- Energy-efficient sliding door drive
ES PROLINE
- Double and triple glazing
- Minimises any temperature-influenced
door deformation by using torsion-resistant struts
- Certified by independent testing institutes

Profile system

Build-up of the ST PRO Green sliding door set

- 01** ES PROLINE sliding door operator, capable of handling door weights up to 2 x 200kg
- 02** Centre sealing profile with optional multipoint locking system
- 03** Floor guide
- 04** Secondary closing edge
- 05** Triple glazing
- 06** Structural connection

- LW:** Clearance width
- LH:** Clearance height
- B:** Width
- OH:** Skylight height
- H:** Total system height
- AH:** Drive height 100 or 150 mm dependent on version
- OKFF:** Upper edge of finished floor prefabricated floor

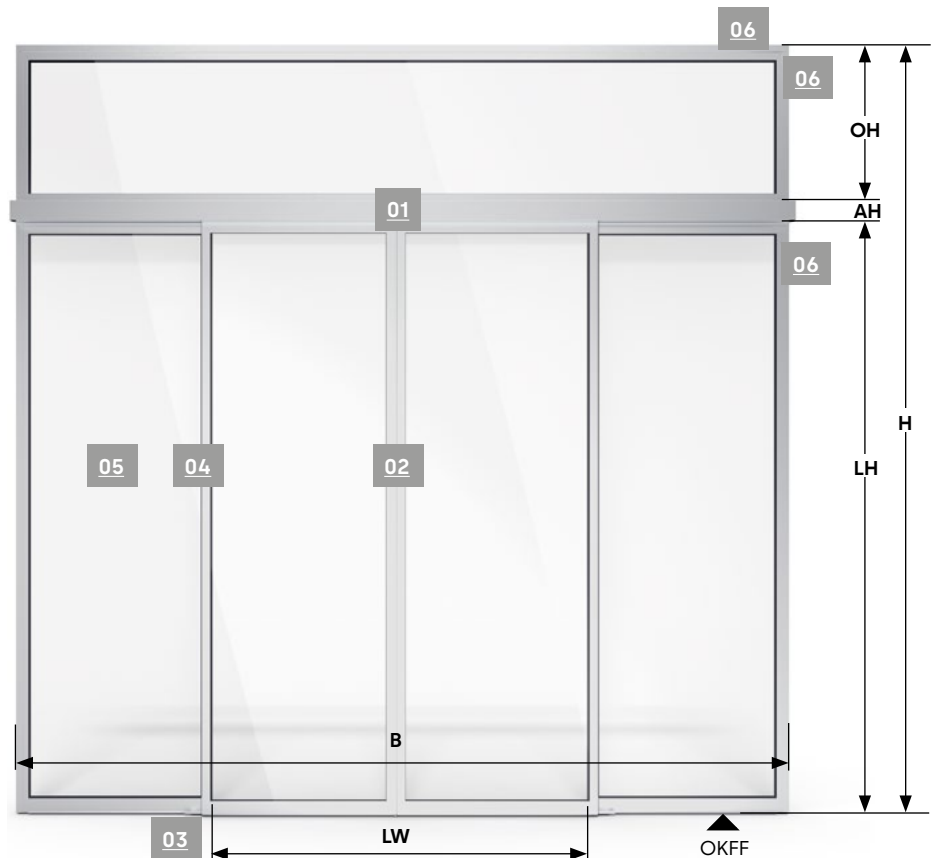

Customised sliding door systems as standard

Each system is individually planned and produced. The modular approach of our systems ensures a cost-efficient realisation. Each system can be easily extended with further automatic and access functions from the dormakaba range but also with third-party manufacturer components.

Freedom of choice of size and design

You are free to choose the dimensions of the sliding door systems. Depending on the sliding door system the selected glazing and the door leaf weight, passageway widths of up to 3,000 mm are possible. The profile surfaces are as standard anodised or powder-coated in custom colours from established powder manufacturers. For special requirements, e.g. in swimming pool construction or near the coast, more resistant coatings are also possible.

Service right from the planning stage

We support every project right from the planning stage. In this, architectural and functional requirements are always the starting point. Each sliding door system is delivered ready for installation. The systems are installed, put into use and serviced by companies certified by us. Extensive documentation in the local language is supplied with each system. For the exact planning details, please refer to our CAD drawing documents. The dormakaba sales department will be happy to advise.

System planning

These dimensions you should know

Opening to one side

Opening to both sides

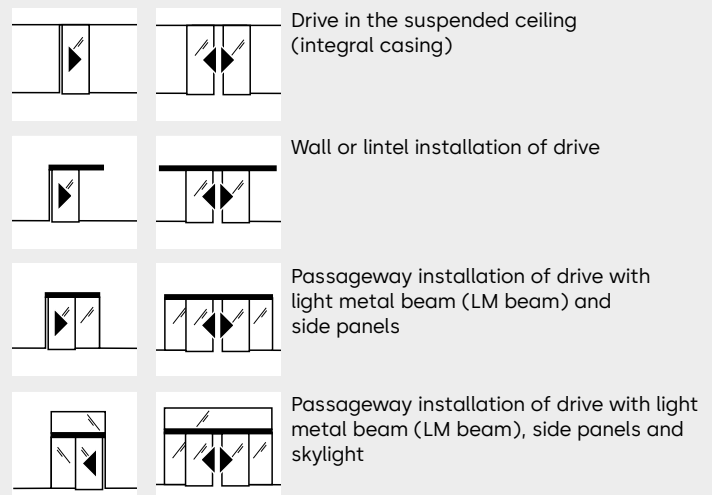
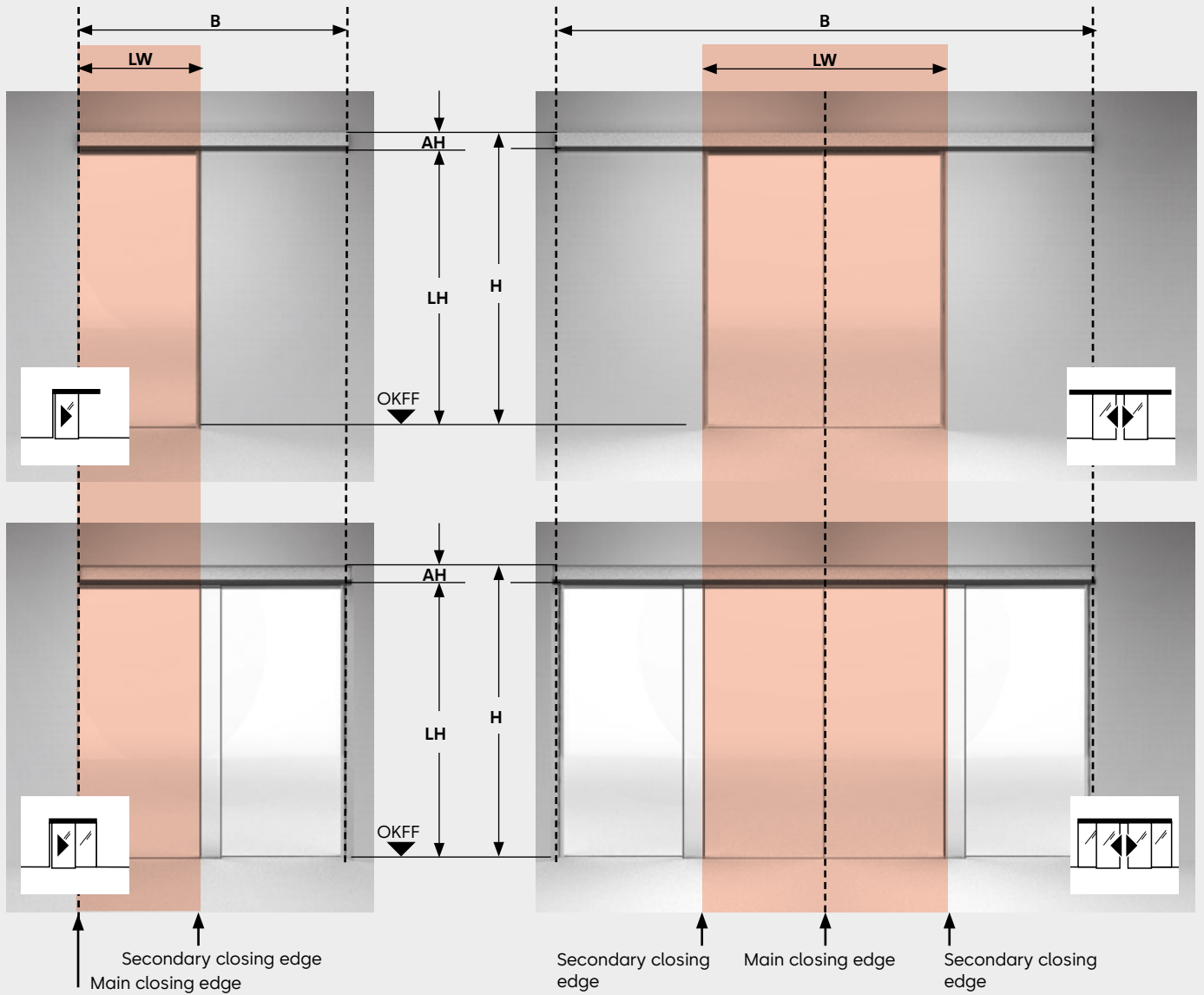

- LW:** Clearance width
- LH:** Clearance height
- B:** Width
- OH:** Skylight height
- H:** Total system height
- AH:** Drive height 100 or 150 mm dependent on version
- OKFF:** Upper edge of finished floor prefabricated floor

ST PRO Green

Thermally separated profile system

Properties

- Complies with the current German Building Energy ACT GEG (formerly EnEV)
- Particularly low U_D values up to 1.0 W/m²K calculated individually for each door system
- Minimised profile face widths
- Above-floor and underfloor routing possible
- Drive height 100 mm or 150 mm
- Certified thermal conductivity values to EN ISO 10077
- Environmental Product Declaration (EPD) included

Glazings

- Double glazing ISO 34 with warm edge
- Triple glazing ISO 50 with warm edge
- Special glazing



Possible additions

- Protective leaf in front of the moving leaf or in the façade
- Georgian bar profile
- Underfloor routing
- Main closing edge with multi-point locking system

Approximate determination of door leaf weight

$$T_G = \frac{LH [m] \times LW [m] \times \text{glass weight [kg/m}^2]}{\text{Number of door leaves}} + 7.5 \text{ kg}$$

Common glass weight for triple glazing: 45 kg/m²

		Version	ST PRO Green
Drive type		Standard	ES 400 PRO
		Escape route 	ES 400 PRO FST
Door parameters*			
System width (B) min. =	1-leaf	Passageway installation (without safety clearance)	2 x LW + 153 mm
		Wall mounting	2 x LW + 115 mm
	2-leaf	Passageway installation (without safety clearance)	2 x LW + 180 mm
		Wall mounting	2 x LW + 120 mm
Clearance width LW²	1-leaf	Standard	700 – 3000 mm
		Escape route 	700 – 3000 mm
	2-leaf	Standard	800 – 3000 mm
		Escape route 	800 – 3000 mm
	1-leaf	ES 400 PRO/ES 400 PRO FST	1 x 250 kg
	2-leaf	ES 400 PRO/ES 400 PRO FST	2 x 200 kg
Clear passage height LH*			2050 – 3100 mm

* The maximum practicable dimensions are subject to the respective door plans and door requirements and also depend on the profile system selected. For doors with tested anti-intruder protection, increased requirements are placed on the structural tolerances as well as the careful design of the structure

²The minimum clearance width for escape route sliding doors is laid down in the respective regional building codes and may vary in certain circumstances.

Main closing edge variants

- LW:** Clearance width
- LH:** Clearance height
- B:** Total system width
- OH:** Skylight height (option)
- H:** Total system height
- AH:** Drive height 100 or 150 mm dependent on version
- OKFF:** Upper edge of finished floor prefabricated floor

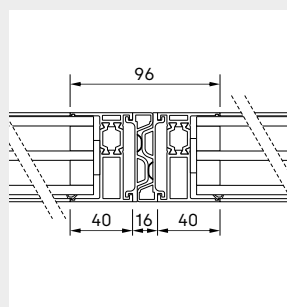

Opening to both sides

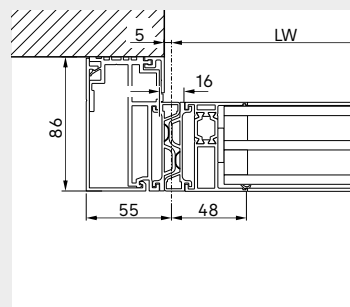

Lintel installation, opening to one side

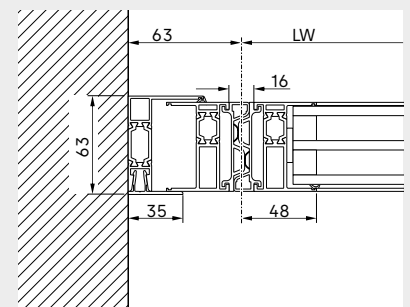

Passageway installation, opening to one side

Installation variations and drive casings

- 01** Sensor casing 100 mm
- 02** Integral casing overall height 100 mm
- 03** Standard casing 100 mm
- 04** Integral casing overall height 150 mm
- 05** Standard casing 150 mm

Note on installation with light metal beam

For doors with side panels and light metal beam, the drive must either be suspended or the 150 mm drive type is required for door leaf weights of approx. 125 kg or more – depending on the clearance width.

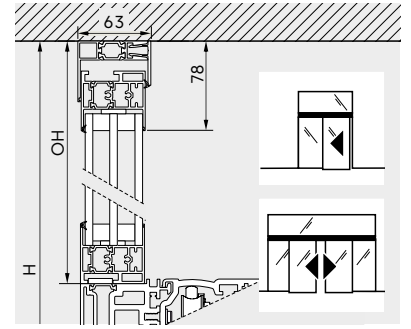

Installation in suspended ceiling

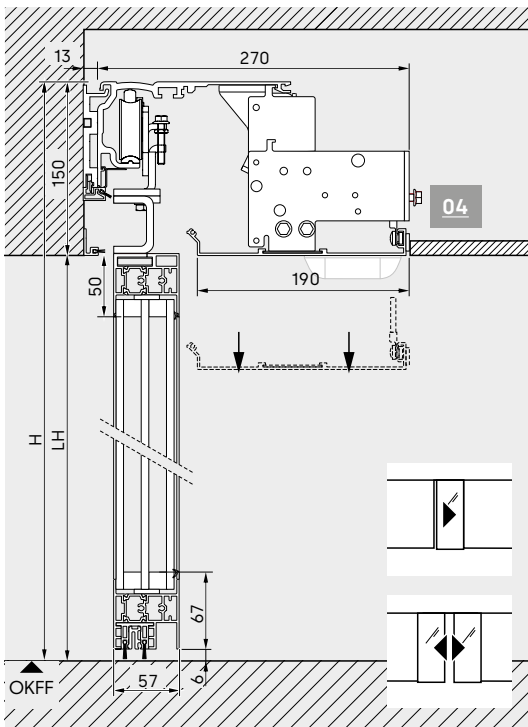
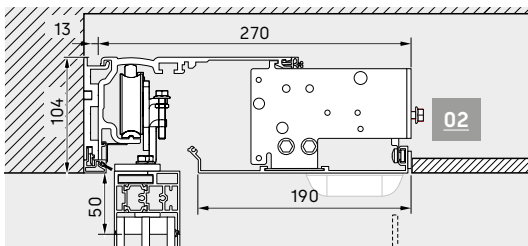

Wall/lintel installation

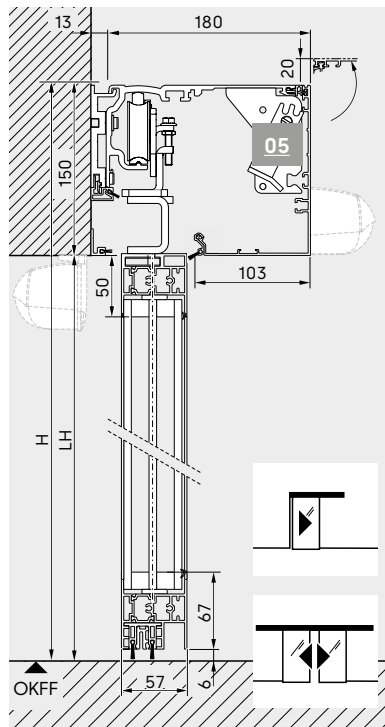
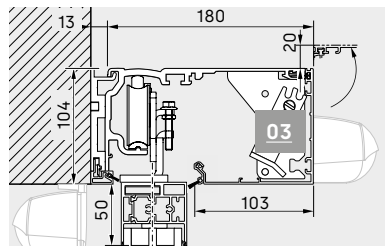
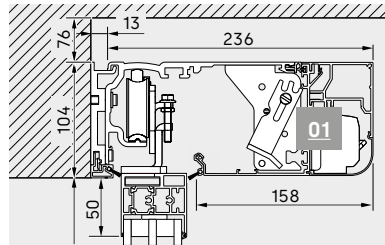

Installation with light metal beam

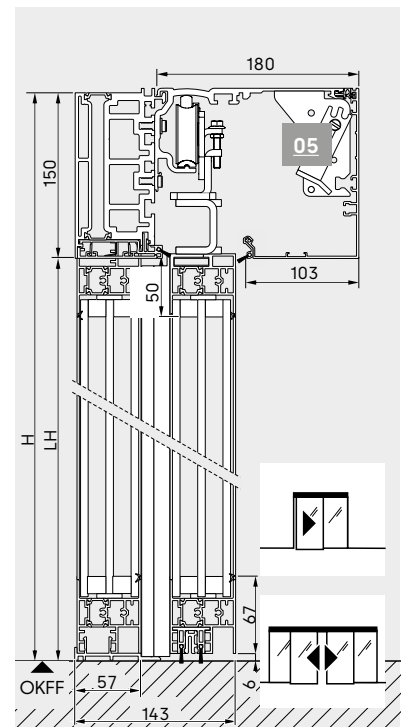
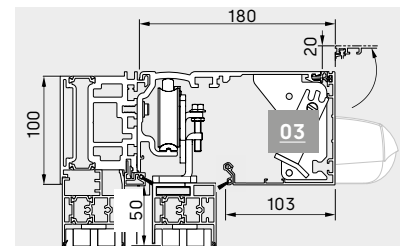
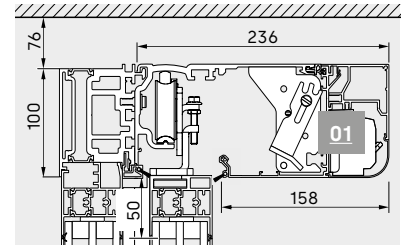

Secondary closing edge variants

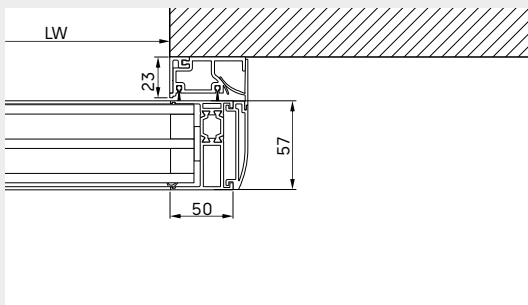

Lintel installation variant

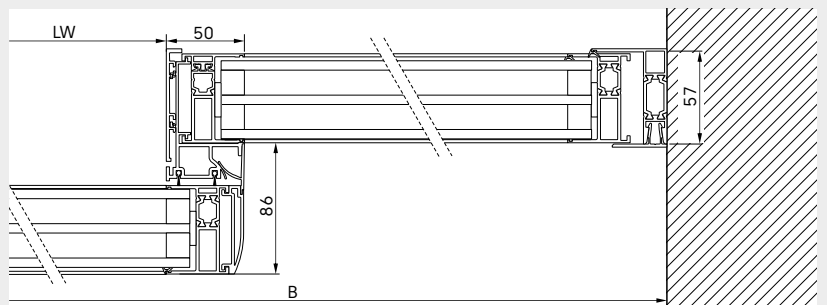

Variants with side panels

Casing variants



Standard casing

The standard casing for ES PROLINE operators is available in two different versions (height 100 mm, 150 mm). A cover bracket is supplied as standard and allows the casing to be opened in three different positions.

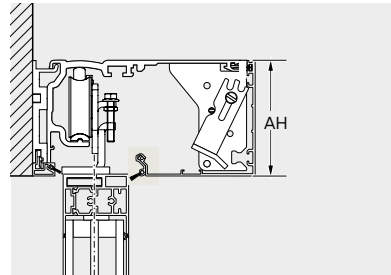

Sensor casing

Sensor casing is the right solution when it comes to premium design requirements. It creates a sleek look for doors with 100 mm drive heights. Activation and safety sensors are integrated into the drive system. There is no need for disruptive additional units and visible components. The sensor casing is approved for doors with a clear passage height of max. 3000 mm.

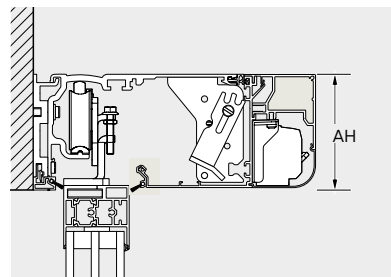

Integrated casing

Integrated casing allows the ES PROLINE operator to be elegantly concealed in suspended ceilings. The operator cover can be detached from below to allow easy access to all the components when carrying out maintenance tasks. Special accessories sets make it possible to integrate the safety sensors in the cover so that the entire height of the passage area can be used.

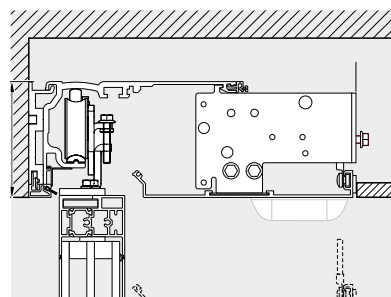

Additional track rail suspension

Optionally available, for instance, for particularly heavy skylight weights.



Additions sliding door system

Protective leaf to safeguard the travel path

A protective leaf safeguards the sliding door's travel path. The protective leaf can be opened as required, e.g. to clean the glass.

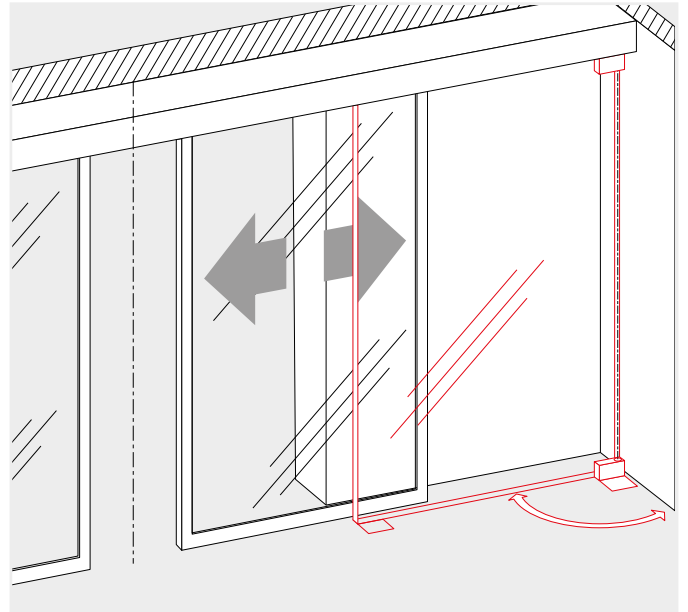

Protective leaf in mullion-transom façades

In mullion-transom façades a protective leaf can safeguard the "clear" space of the façade construction. The protective leaf can be opened as required, e.g. to clean the glass.

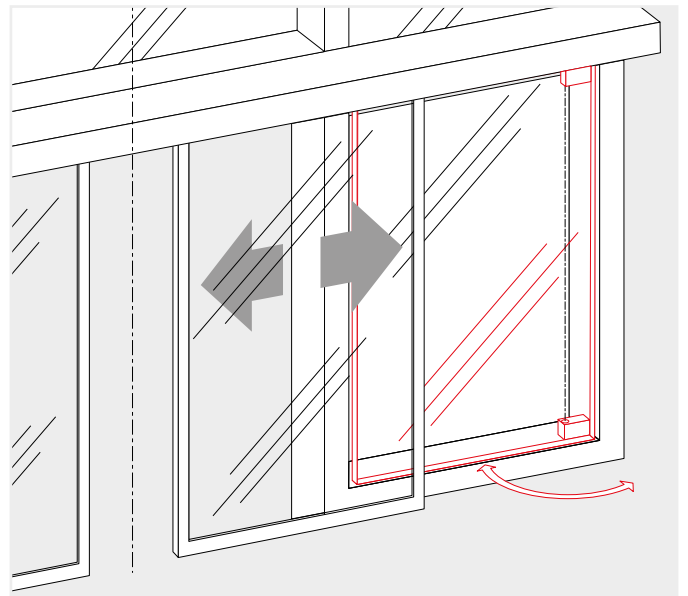

Georgian bar profiles

The door leaves, side panels and skylights can be partitioned as desired with Georgian bars. The Georgian bars serve as a decorative element or even a simple "shock protection". The exposed width of the Georgian bars is 90 mm.

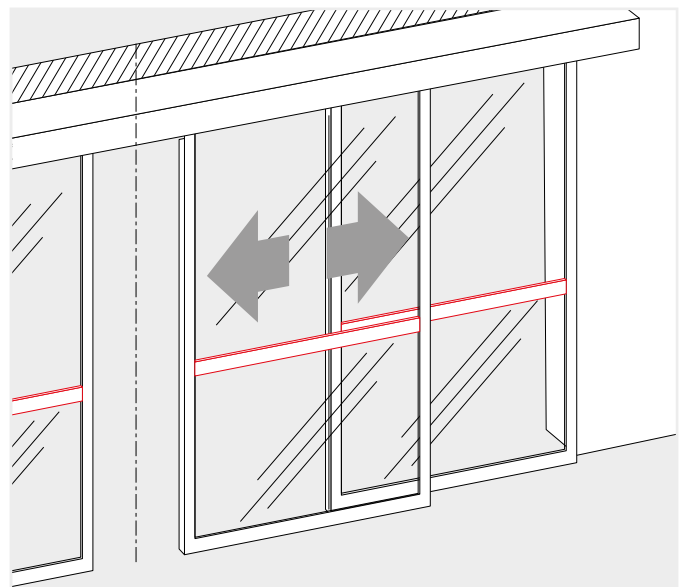
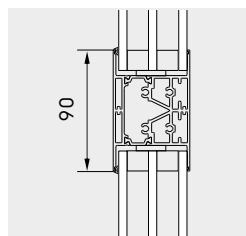

Locking devices

dormakaba offers a range of locking device variants for the ES PROLINE to prevent unauthorised access to buildings by opening the sliding door.

Electro-mechanical belt locking device

The self-adjusting locking device is attached directly to the drive unit of the operator. The standard lock status signal contacts increase the operational safety of the door.

The locking device function is configured ex works to be bistable; this means that the locking device status is maintained in the event of a power failure. Versions with other functions (monostable with Failsafe: opens the locking device in the event of a power failure and Failsecure: closes the locking device in the event of a power failure) are also available.



Magnetic locking device (FIA) for escape route and emergency exit doors

When using the magnetic locking device and the ES PROLINE control variant, you can lock an escape route sliding door in all automatic program switch positions, even when persons are present in the building.

The locking device system has been type-approved by the German Technical Inspectorate and does not require approval in each individual case.

This variant is suitable for all properties that are used 24 hours a day, such as self-service areas in banks, hotels, hospitals, schools, etc. Any person can leave the building safely in case of an emergency and the door provides protection against uninvited guests.



Electromotive hook locking device

Fitted as standard to the ST PRO Green RC2 and RC3 variants (doors with increased anti-intruder protection) this robust multi-point locking device is available as an option for ST PRO Green to provide an increased level of break-in protection. Solid swing bolts are extended by a motor to lock the door. Mechanical unlocking devices for opening doors manually are optionally available.

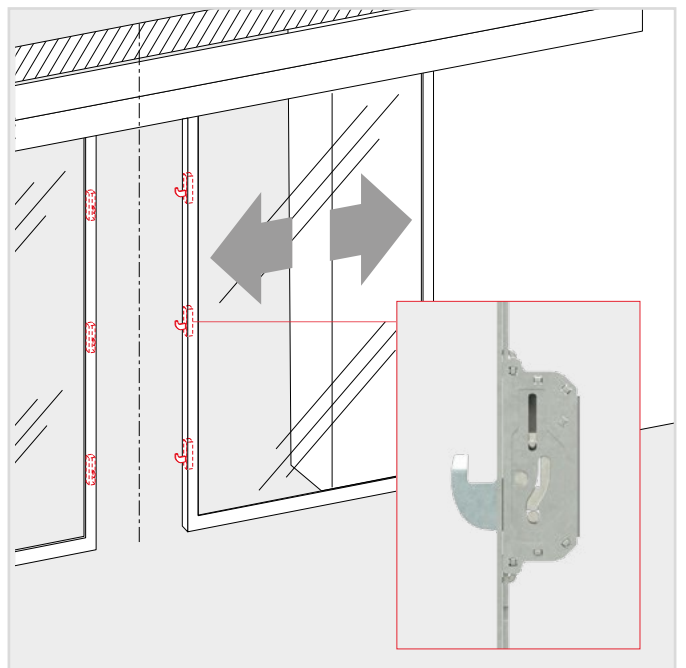

Manual release

Manual release on the door leaf

With electromotive hook locking, a door can be manually locked and unlocked on the sliding door leaf. For 1-leaf doors, the release is always located on the door leaf. For 2-leaf doors, the release is located on the right-hand door leaf.

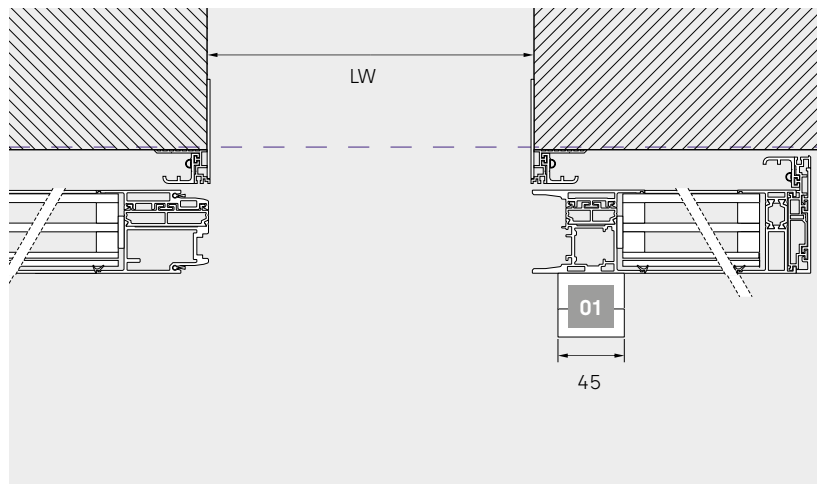
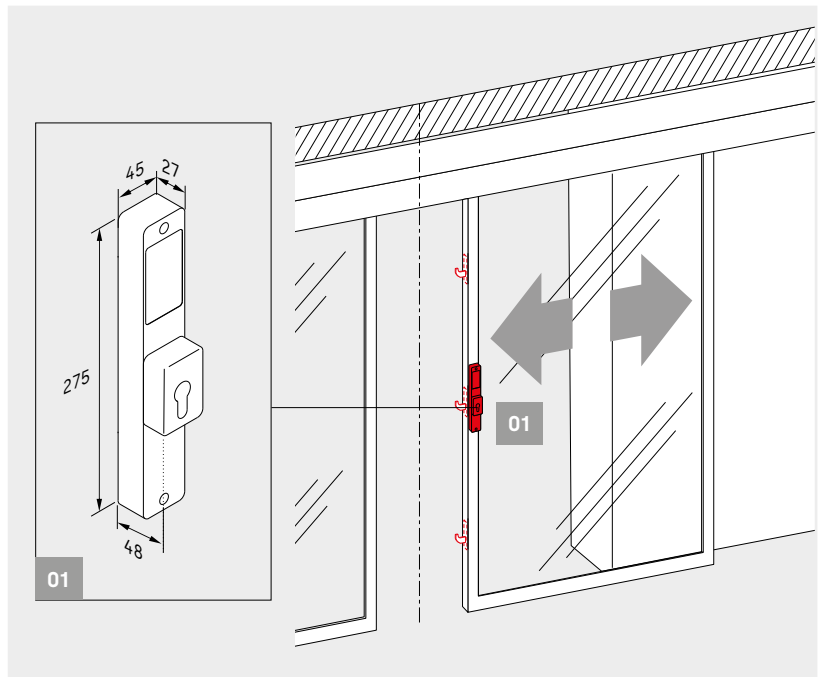

If the sliding door system is equipped with a manual release and a protective leaf, the clearance width LW is reduced by 83 mm for 1-leaf systems and 166 mm for 2-leaf door systems.

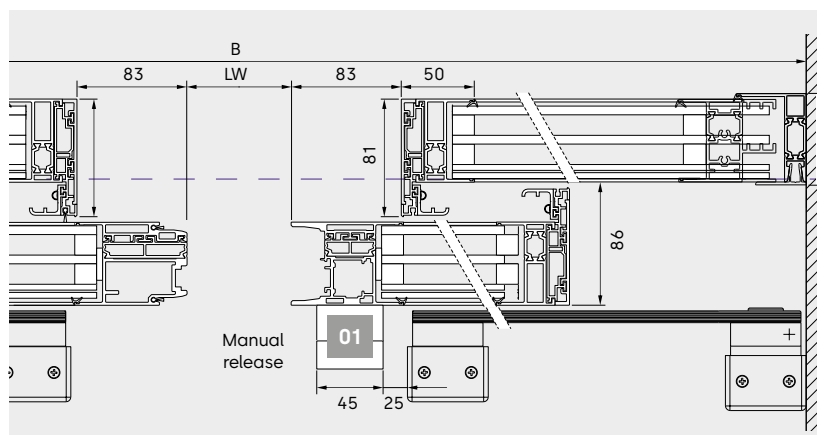

Technical data for sliding doors

		ST PRO Green
Drive unit and door system tested for 1.5 million operating cycles		●
Glass	Security insulating glass	●
	Security insulating glass according to DIN EN 356 RC2: grade P4A	○
	RC3: grade P5A	
Construction	With side panels	○
	With skylight	○
	With safety screens	○
	Continuous floor guide	○
Locking device	Electro-mechanical belt locking device	○
	Manual lock release for electro-mechanical locking device	○
	Magnetic locking device, jam-free	○
	Electromotive hook locking device	○
	Manual lock release for electromotive locking device	○
● Yes ○ Optional – No		





Connections with CAN-bus technology

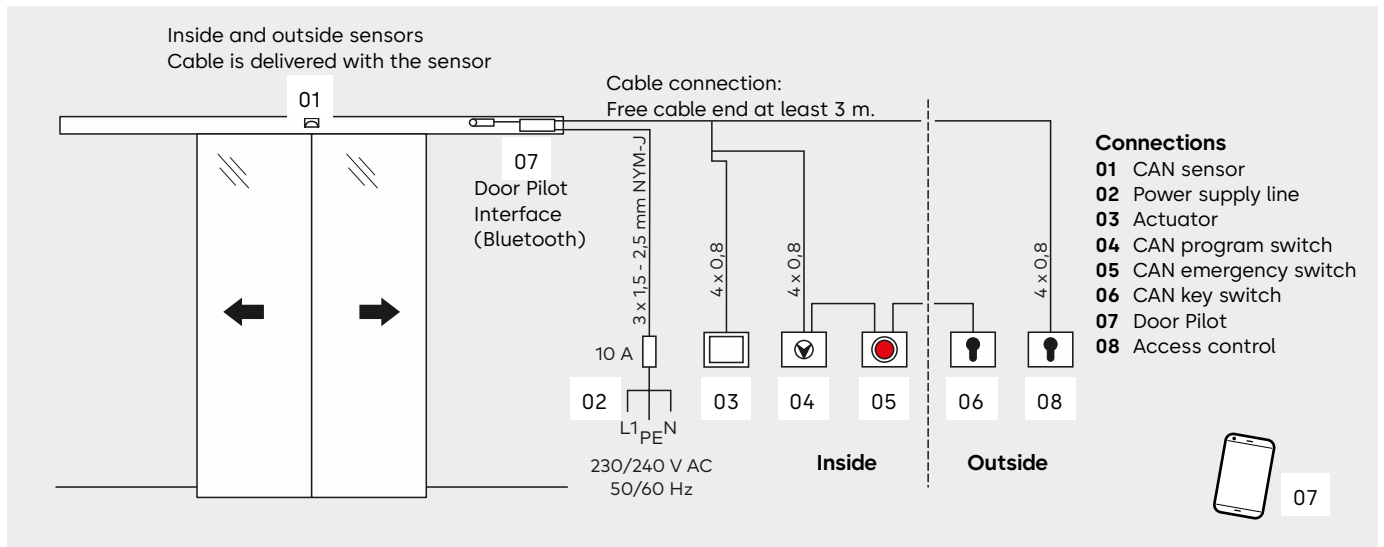

Technical data for sliding door operators

- 01 Battery
- 02 Door Pilot interface
- 03 Expansion modules
- 04 Drive unit
- 05 Power supply unit

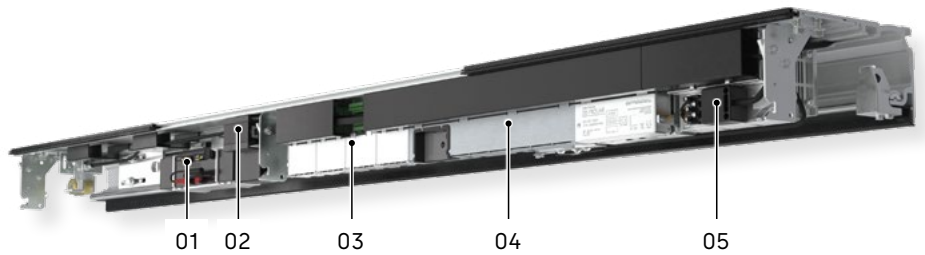

	<u>Standard Sliding Door</u>	<u>Escape Route Sliding Door</u>
Door parameters	ES 400 PRO	ES 400 PRO FST
Min. operator length	2 LW	2 LW
Operator depth in mm	180	180
Operator height in mm	100	100
Use in escape routes and emergency exits	-	
Force limitation in accordance with EN 16005/DIN 18650	●	●
Operating noise	<47 dB(A)	<47 dB(A)
Settings		
Opening speed (adjustable in increments)	10 – 90 cm/s	ca. 20 – 90 cm/s
Closing speed (adjustable in increments)	10 – 90 cm/s	10 – 90 cm/s
Low speed OPEN	0 – 9 cm/s	0 – 9 cm/s
Low speed CLOSE	3 – 9 cm/s	3 – 9 cm/s
Hold-open time, night/bank hold-open time	0 – 180 s	0 – 180 s
Night/bank opening delay	0 – 10 s	0 – 10 s
Partial opening	25 – 300 cm	25 – 300 cm
Low-speed travel OPEN/CLOSE	0 – 30 cm	0 – 30 cm
Power supply		
Supply voltage	230 V, 50/60 Hz	230 V, 50/60 Hz
Power consumption	180 W	180 W
On-site line fuse	10 A	10 A
Degree of protection	IP 20	IP 20
Power supply for peripheral equipment under network conditions	24 V DC/2A	24 V DC/2A
Power supply for peripheral equipment in the event of a power failure (battery operation)	Optional 21–27 V DC/2A	21–27 V DC/2A
Temperature range	-20 – + 60 °C	-20 – + 60 °C
Permissible air humidity (relative) (non-condensing)	max. 93 %	max. 93 %
Standardisation and testing		
Compliant with the Low Voltage Directive and the EMC Directive	●	●
Monitoring of secondary closing edges verified to fulfil German standard DIN 18650 and EN 16005.	●	●
Manufactured to ISO 9001	●	●
Environmental product declaration according to ISO 14025; declaration holder: Institut Bauen und Umwelt e.V.	●	●

Control module	ES 400 PRO	ES 400 PRO FST
Modular design	●	●
Function programs		
– Off	●	●
– Automatic	●	●
– Permanent open	●	●
– Partial open	●	●
– Exit	●	●
Automatic reversing	●	●
Connection for securing the passageway (on both sides)	●	●
Tested in accordance with EN 16005/DIN 18650	●	●
Securing main and secondary closing edge(s) according to EN 16005/DIN 18650	●	●
Basic parameters set using integrated display and buttons	●	●
Parameterisation via Operator Service Interface (OSI)	●	●
Door Pilot interface (Bluetooth)	○	○
Automatic opening/closing in the event of a power failure (if a battery set is used)	●	● (Battery set supplied as standard)
Emergency battery operation (if a battery set is used)	●	–
24 V DC output for external appliances	●	●
Readable fault memory with fault codes	●	●
CAN interface for connecting a program switch	●	●
CAN interface for connecting additional CAN-bus components	●	●
Multiports for connecting accessory components	4	4
Functions*		
Pharmacy function	●	●
Door status signal contacts	●	●
Panic closing (observe regional regulations!)	●	●
Door bell contact	●	●
Airlock control	●	–
Synchronous operation	●	●
Safety deactivation	●	●
Night/bank function	●	●
Emergency open	–	●
Emergency stop	●	–
Configurable partial opening distance	●	●
Slide and Go	●	●
Close/open on malfunction	●	●
Fire service switch function	●	●
*The functions can be implemented by the master controller or by the 4 I/O modules.		
Safety and activation (SiAK) expansion module**		
For connecting conventional (not CAN-bus-capable) safety and activation sensors	○	○
Program switch (MS) expansion module**		
For connecting conventional (not CAN-bus-capable) program switches	○	○
Auxiliary equipment		
Battery set	○	●
Emergency power supply UPS (external)	○	○
Module for connection to LON/LAN building control systems	○	○
Potential-free relay contact	○	○

● Standard ○ Optional

** Further information on the expansion modules can be found on the next page

Master controller functions and optional expansion module functions



A wide variety of functions can already be tapped into just using the master controller for the ES PROLINE sliding door operators. The optional expansion modules can be used to implement various special functions and connect conventional accessories that are not based on CAN-bus technology.

Master controller	PRO	PRO FST
Pharmacy function/pharmacy door opening The door can be locked in a partially open position apart from when the program switch is in the "Off" position. This allows a pharmacy to dispense goods securely outside business hours, for example.	●	●
Door status signal contacts This function issues door statuses. E.g. Door open/closed/locked, System OK, Current door position.	●	●
Panic closing This function closes the door immediately and switches off passage security and force limitation. This function is only permissible in certain countries (observe regional regulations).	●	–
Door bell contact For connecting an on-site door bell or an audible indicator.	●	●
Airlock function The doors can be switched to function as a personal interlock (not for escape route systems).	●	–
Synchronous operation For instance, two doors opening on one side can be switched to act as one large, double-leaf door. This allows particularly wide opening distances or high door leaf weights to be achieved.	●	●
Safety deactivation The door can be opened or closed by pressing a button.	●	●
Night/bank function Allows the connection of access controls, key switches etc. with the program switch in the "Off" position. The door unlocks – opens – closes – locks.	●	●
Emergency open	–	●
Emergency stop	●	–
Configurable partial opening distance	●	●
Slide and Go An opening signal can be triggered by gently pushing the door leaf.	●	●
Unlock/lock in case of malfunction In case of system malfunction, a door can be deliberately triggered to close and lock or unlock and open.	●	●
Fire service function Used to deliberately open and close a door via a separate signal input.	●	●

● Function can be implemented via the four programmable inputs and outputs. – Function is not implementable

Expansion modules	PRO	PRO FST
4 I/O Expansion module The 4 I/O module is capable of four inputs and four outputs. The master controller functions can be implemented if the master controller connections have already been assigned. Only one module can be used at a time.	○	○
Safety and activation (SiAK) expansion module The safety and activation (SiAK) expansion module is used to connect conventional accessories, such as sensors and radar detectors. Safety sensors can be connected either for the main closing edge (MCE) or the secondary closing edge (SCE). Two modules are required in order to combine these safety functions (MCE/SCE).	○	○
Program switch (MS) expansion module Used to connect a conventional program switch (mode switch/MS) that is not based on CAN-bus technology. Only one module can be used at a time.	○	○

○ optional – not extendable

Door Pilot interface





The dormakaba Door Pilot app allows automatic doors to be easily controlled from a smartphone. Operators from the ES PROLINE series can be equipped with the Door Pilot interface as an option. The app is available in iOS and Android versions and can be obtained from the respective app store.

Program switch functions

Use 6 different functions:

automatic	Opens from the inside and outside – perfect for normal opening hours.
Partial opening	Opens from the inside and outside with reduced opening width – ideal for cold winter days.
Output	Opens from the inside only – ideal for use shortly before closing time.
Permanent Open	Door is permanently open – suitable for deliveries or ventilation.
Off	Door remains closed (and perhaps locked) and can only be opened by changing the program switch position or by an externally controlled impulse.
Open-once	For easy opening in close proximity (not possible with the program switch in the "Off" position).

Door status signal contacts

 System OK!	 Service due!	 Error detected, system check necessary!
System OK	Maintenance due	Fault detected, service due

Customer benefits

- Complement to the program switch, convenient operation from a smartphone.
- Check functions easily without needing specialist knowledge.
- No need to incorporate into existing building network.
- Direct contact function for simplified/direct access to dormakaba Service.

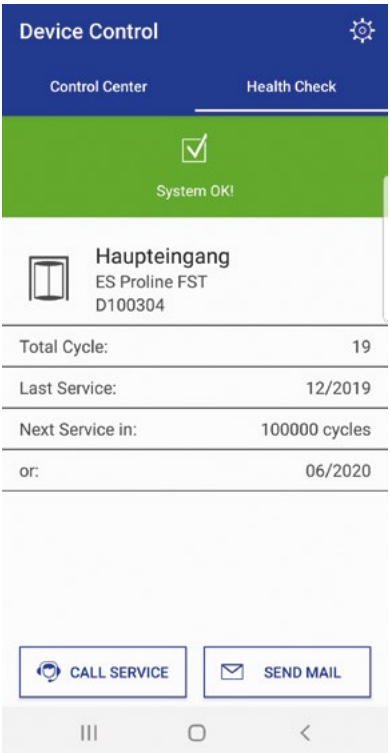
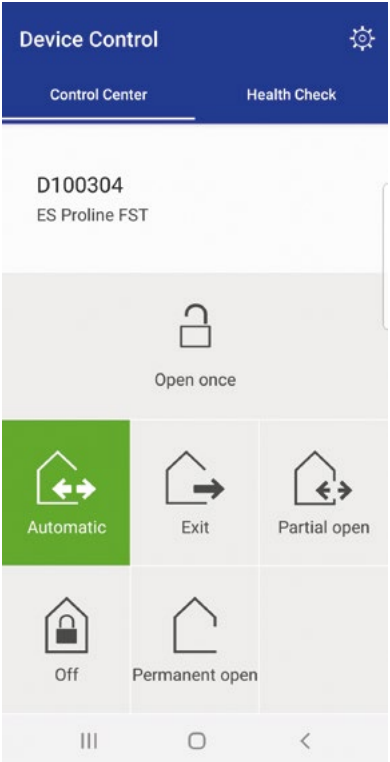

Wide range of accessories from dormakaba

Program switches

When combined with a program switch from the dormakaba accessories range, the automatic door system can satisfy all kinds of individual operating requirements and is easy to use. The program switches have been designed in various versions and for a wide range of requirements.

The options range from mechanical to fully electronic versions locked by your choice of profile cylinders, round cylinders or fully electronic coding.

- Up to 5 different functions: Off, automatic, exit only, partially open, permanent open
- Electronic program switches in System 55 design for the most discerning aesthetic demands

**For sliding door operators without escape route
and emergency exit requirements**

Article no.

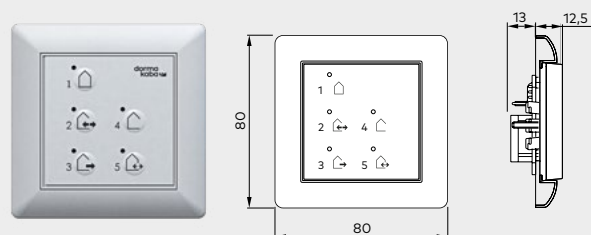

EPS fully electronic program switch

System 55 design, 5 positions, lockable using coding or additional TL-ST S55 key switch, membrane keypad, concealed, 80 x 80 mm

EPS CAN	White	16712501150
Box for surface mounting		5158533332
EPS CAN (44 x 50 mm)		16712401150

**For sliding door operators in escape
routes and emergency exits**

Article no.

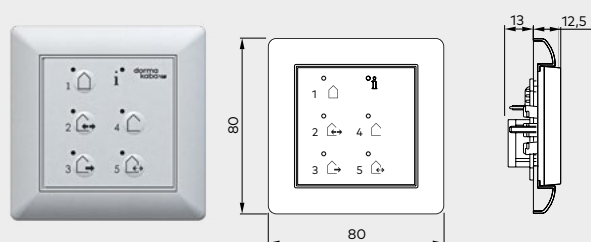

EPS-FST fully electronic program switch

System 55 design, 5 positions, lockable using coding or additional TL-ST S55 key switch, membrane keypad, concealed, 80 x 80 mm

EPS CAN	White	16712501150
Box for surface mounting		5158533332

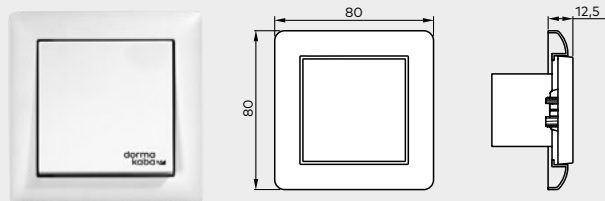
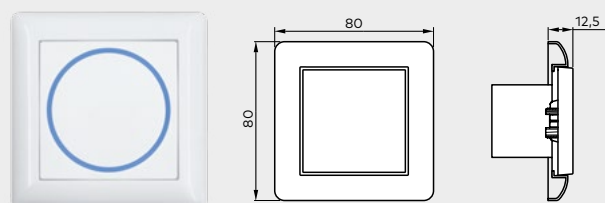

Activation switches

Article no.

CleanSwitch

contactless radar push-button, System 55, flush-mounted, detection zone adjustable 10 - 50 cm, dimensions: 80 x 80 x 40 mm, switch insert 55 x 55 mm, colour: white

CleanSwitch	neutral	16737401170
	wheelchair	16737501170
	door open	16737601170

Manual release switch

Single-pole change-over contact, single frame, concealed, System 55

Manual release switch	White	19144701170
-----------------------	-------	-------------



Key switch

Article no.

KT 3-1

1 NO contact with Europrofile half-cylinder in line with DIN 18252, half 30–32.5 mm, length 40.5–43.5 mm, locking cam position left (90°) (interchangeable with master-key system half-cylinder), key can only be removed in neutral position, aluminium, metal, 75 x 75 x 60 mm

KT 3-1 UP	Concealed	05054531332
KT 3-1 AP	Surface-mounted	05054631332

KT 8

Labelled "Open"/"Closed", 2 NO contacts with Europrofile half-cylinder in line with DIN 18252, half 30–32.5 mm, length 40.5–43.5 mm, locking cam position left (90°) (interchangeable with master-key system half-cylinder), key can only be removed in neutral position, aluminium, metal, 75 x 75 x 60 mm

KT 8 UP	Concealed	05054831332
KT 8 AP	Surface-mounted	05054931332

TL-ST S55

Push button with single-pole changeover contact for on-site Europrofile half-cylinder in line with DIN 18252, half 30–32.5 mm, length 40.5–43.5 mm, locking cam position left (90°), with cover for System 55, not suitable for surface-mounted boxes, without Europrofile half-cylinder, **without frame**.

TL-ST S55 W	White	56330710
TL-ST S55 S	Silver	56330701
TL-ST S55 A	Anthracite	56330715

KT 3-2

1 NO contact with Europrofile half-cylinder, interchangeable with master-key system half cylinder, key can only be removed in neutral position, cover panel for replacement, labelled "Open"/"Closed", aluminium, concealed: 125 x 100 mm, surface-mounted: 70 x 90 mm

KT 3-2	05054731332
--------	-------------

Key switch CAN

Switch with single-pole changeover contact, with Europrofile half-cylinder in line with DIN 18252, half 30–32.5 mm, length 40.5–43.5 mm, locking cam position left (90°) (interchangeable with master-key system half-cylinder), with cover for System 55, not suitable for surface-mounted boxes, without frame.

Schlüsseltaster CAN	16715801150
---------------------	-------------



LED touch key

Article no.

LED touch key

Manual actuator with plastic frame in white, similar to RAL 9016 and traffic grey similar to RAL 7043

LED touch key	16672601170
---------------	-------------

LED hygienic touch key

Manual actuator, tempered glass encapsulated, glass button surface, hygienic version in line with EN 1672-1/2

LED touch key	16672901170
---------------	-------------

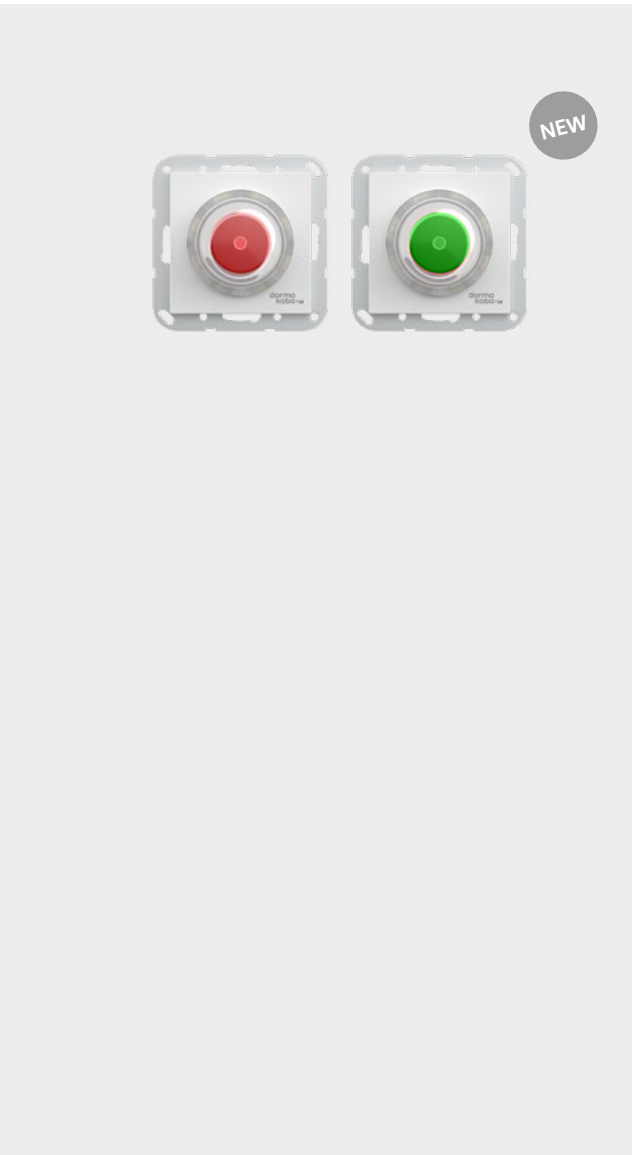

Emergency activation buttons

Article no.

Emergency switch CAN

CAN-bus emergency activation button, red knob (emergency activation button off) or green knob (emergency open), System 55, without frame.

Emergency switch CAN, red	16718501150
Emergency switch CAN, green	16718502150

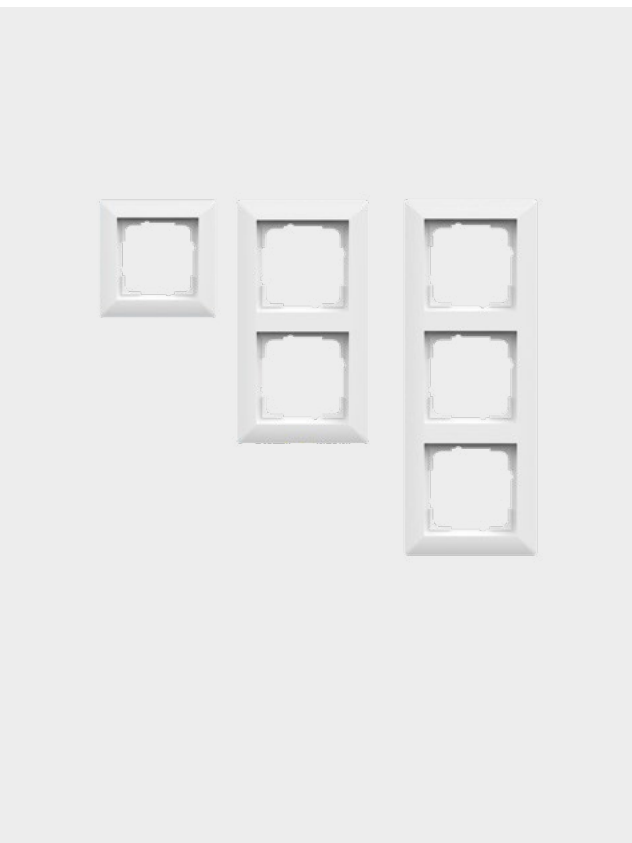

Cover frame for buttons and switches

Article no.

Standard System 55

FR-S55 1	Single frame, white, 80.7 x 80.7	56391110
FR-S55 2	Double frame, white, 151.8 x 80.7	56391210
FR-S55 3	Triple frame, white, 223.3 x 80.7	56391310

E2 System 55 (not shown)

FR-E2W 1	Single frame, E2 55, white, 80.8 x 80.8	56392110
FR-E2W 2	Double frame, E2 55, white, 151.9 x 80.8	56392210
FR-E2W 3	Triple frame, E2 55, white, 223.4 x 80.8	56392310
FR-E2S 1	Single frame, E2 55, silver, 80.8 x 80.8	56392101
FR-E2S 2	Double frame, E2 55, silver, 151.9 x 80.8	56392201
FR-E2S 3	Triple frame, E2 55, silver, 223.4 x 80.8	56392301
FR-E2A 1	Single frame, E2 55, anthracite, 80.8 x 80.8	56392115
FR-E2A 2	Double frame, E2 55, anthracite, 151.9 x 80.8	56392215
FR-E2A 3	Triple frame, E2 55, anthracite, 223.4 x 80.8	56392315

Active infrared sensor and combined sensors



Combined sensor IXIO-D CAN

Combined sensor featuring radar detector with direction recognition and safety curtain for escape route systems and non-escape route systems (CAN-bus technology)

IXIO-D CAN	Black	86800053
	Silver	86800057
	White	86800056

Safety curtain IXIO-S CAN

Safety curtain (tested) IXIO-S CAN for monitoring closing edges (CAN-bus technology)

IXIO-S CAN	Black	86800055
	Silver	86800059
	White	86800058

Integrated combined sensor IXIO-D CAN

Combined sensor (without cover) featuring self-monitored radar detector with direction recognition and safety curtain for escape route and non-escape route systems for integration into the sensor casing.

Integrated IXIO-D CAN	86800050
-----------------------	----------

Integrated safety curtain IXIO-S CAN

IXIO-S CAN safety curtain (tested, without cover) for monitoring closing edges (CAN-bus technology), for integration into the sensor casing.

Integrated IXIO-S CAN	86800052
-----------------------	----------

Accessories for active infrared sensor and combined sensors

Article no.



Ceiling installation set

Ceiling installation system for IXIO-DT and IXIO-S

Ceiling installation set	Black	86800019
	White	86800020

Rain protection cover

Rain protection cover for IXIO-DT and IXIO-ST

Rain protection cover	Black	86800021
-----------------------	-------	----------

Fixing bracket

Fixing bracket for IXIO-DT and IXIO-ST

Fixing bracket	Black	86800016
----------------	-------	----------



Door Hardware



Electronic
Access & Data



Mechanical
Key Systems



Lodging
Systems



Entrance
Systems



Service

Our commitment to sustainability

At dormakaba, we are committed to sustainable development along our entire value chain.

To give quantified data on the environmental effects of a product and its ecological footprint, dormakaba provides Environmental Product Declarations (EPD). You can find our EPDs and further information on our commitment to sustainability here or by scanning the QR code.

www.dormakaba.com/sustainability



WN 05522451532, 10/2023 ST PRO Green,
* Subject to technical modifications without notice.

dormakaba
Wilbury Way
Hitchin
Herts
SG4 0AB

info.gb@dormakaba.com
dormakaba.co.uk