

AX.S SERIES Embedded Access Control

AXIAL

HOW IT WORKS

AXIAL is a .NET client application for managing persons and reporting of Kaba's AX.S systems across multiple locations.

AXIAL provides an administrative interface to all managed system settings, including fingerprint templates. Authorization and site assignment of persons are performed from the AXIAL application and applied to the selected locations. Keeping the intelligence at each individually managed location provides redundancy of critical configuration data.

Additionally, all managed systems forward their events to the AXIAL events database where system reports may be generated across one or many managed locations.

- .NET client for multiple-site management
- Reporting/person administration tool
- Supports third-party integration

Where it Works:

With partitioned visibility on a national or regional level, AXIAL is perfect for:

- Commercial & Retail
- Pharmacies
- Banks
- Government/Ports
- Schools
- Remote sites
- Data centers

SYSTEM DIAGRAM

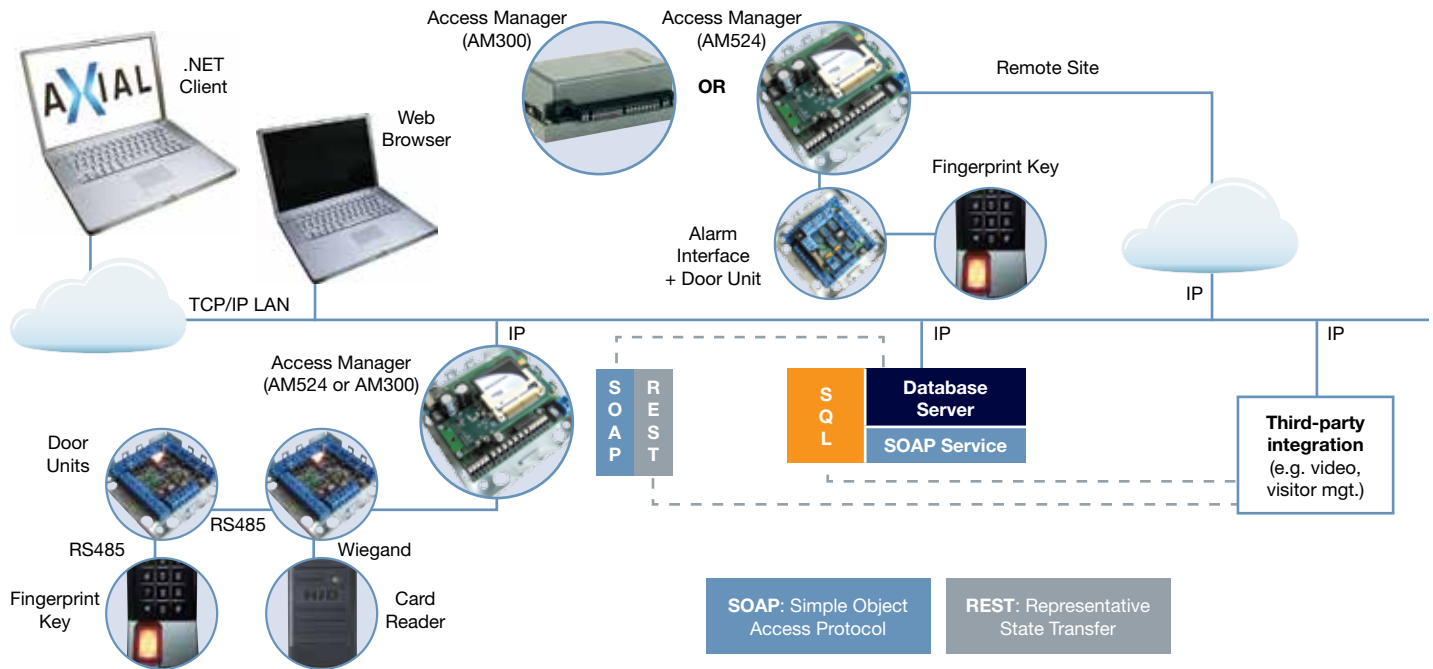

Disclaimer: While reasonable efforts were made to ensure the accuracy of this document at the time of printing, Kaba assumes no liability for any errors or omissions. This information is subject to be revised without notice, and changes may be incorporated in future releases.