

INSTALLATION

ES74F

Electric Strikes

MOUNTING & WIRING INSTRUCTION

- To determine if the Strike Shim positions need adjustment, measure dimension "R" (see Figure 1) from the center to the edge of the latch. When necessary, re-arrange the Strike Shims according to the chart below. The "shipped as default" positions are illustrated in Figure 2.

SHIM PLACEMENT CHART

NOTE: Shims consist of two thin and one thick.
Install with the indicated hardware per the appropriate measurement R range.

Measurement "R"	"S1" Shims	"S1" Screws	"S2" Shims	"S2" Screws
5/16" (8.2mm) or Less	None	M4 x 10mm	1 thick, 2 thin	M4 x 10mm
5/16" - 3/8", (8.2 - 9.7mm)	1 thin	M4 x 10mm	1 thick, 1 thin	M4 x 10mm
3/8" - 7/16", (9.7 - 10.7mm)	1 thick	M4 x 10mm	2 thin	M4 x 10mm
7/16" - 1/2", (10.7 - 12.2mm)	1 thick, 1 thin	M4 x 14mm	1 thin	M4 x 10mm
1/2" - 9/16" (12.2 - 13.7mm)	1 thick, 2 thin	M4 x 14mm	none	none

Shipped as Default

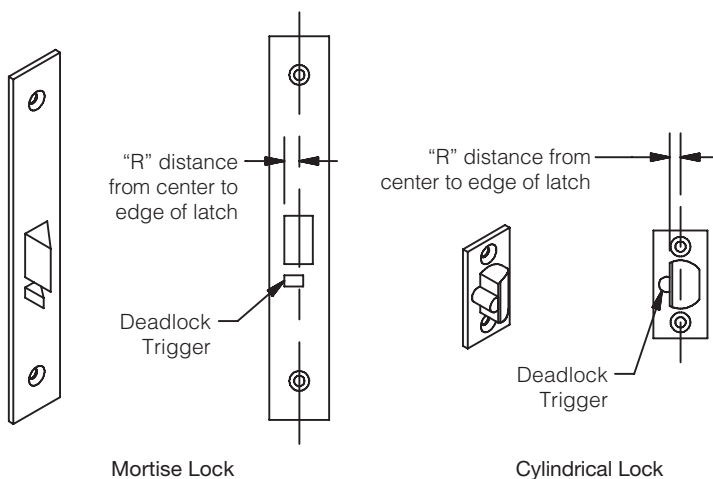

Figure #1

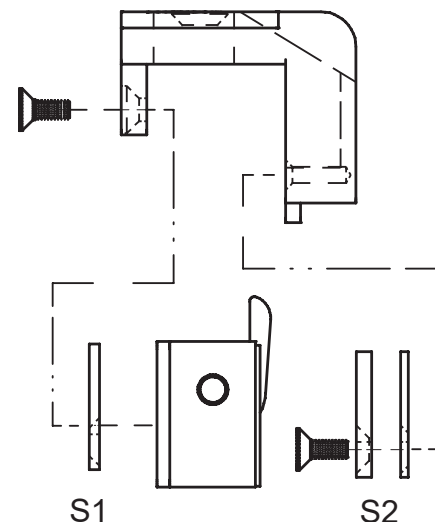

Figure #2

When installing an electric strike on an inactive door of a set of double doors, it can be treated the same as a frame installation in most situations. For more information contact the Technical Services Department.

MOUNTING & WIRING INSTRUCTION Cont'd.

2. Determine the horizontal centerline.
FOR MORTISE LOCKS: Position the strike against the edge of the door with the deadlock trigger fully on the strike's angled ramp and the latch within the strike cavity. Move door close to the frame. The horizontal centerline is clearly molded into the strike's pry-guard. Transfer onto door frame.

FOR CYLINDRICAL LOCKS: Simply align the center of the latch with the center of the strike cavity. Move door close to the frame. The horizontal centerline is clearly molded into the strike's pry-guard. Transfer onto door frame.

3. Determine the vertical centerline of the door lock face, carefully considering any stops or gasket and transfer onto the door frame.
 4. Use the vertical and horizontal centerlines marked

on the drawing below to prepare the door frame for cutting.

5. If required, install the optional "no weld" mounting tabs per page 4.
 6. Connect the incoming wiring from the power supply to the terminal screws on the strike insert. DORMA door strikes are not polarity sensitive, although be certain to observe proper polarity if a suppression diode is required for access control applications. To meet BHMA A156.31 install the MOV provided across the red & black wires.
 7. Install the door strike in the door frame using the screws provided.
 8. See Insert Tips on page 3.

ES74F

MEASUREMENT	FRACTIONAL INCHES	DECIMAL INCHES	METRIC mm
A	1-1/4"	1.25	31.8
B	4-7/8"	4.87	123.8
C	3-3/8"	3.38	85.7
D	1-1/2"	1.50	38.1
E	3/8"	0.38	9.5
F	1/8"	0.13	3.2
G	1-11/16"	1.69	42.9
X	Vertical Centerline of Door Lock and Mounting Face Plate		
K	4-1/8"	4.13	104.8
M	12-24	N/A	N/A

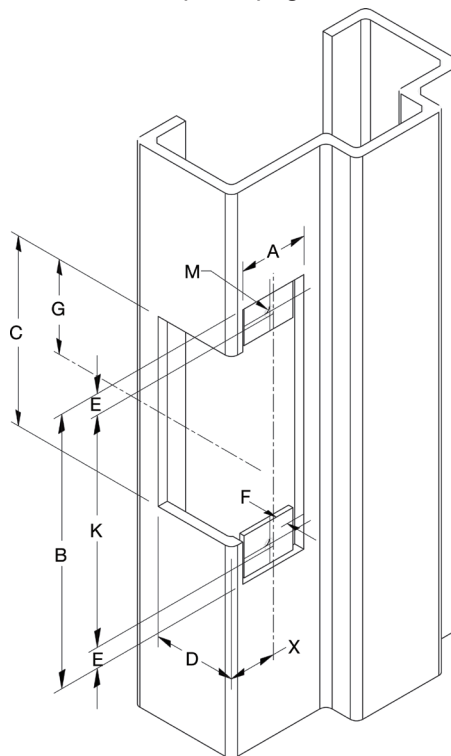

NOTE: Specifications subject to change without notice.

* Dimension F is measured from face of mounting tab to face of frame.

INSTALLATION SEQUENCE TIPS

These photos show three simple steps to a quick and easy strike insertion.



Frame Preparation:
Should the frame not be cut out for the ES74F, follow the directions provided on page 2.



Initial Position:
Place the strike as shown with the mounting tab located between the face plate and the insert.



Strike Position:
Rotate the strike into the frame. Note that the strike is angled slightly forward to clear the Pry-Guard.



Final Push:
Push the strike into the frame. The pry-guard should be behind the front lip of the frame.



Ready to Secure:
The strike is now in position ready to be secured by the two (2) 12-24 mounting screws.

MOUNTING TAB KIT INSTRUCTIONS

Mounting tab kit is for use with aluminum and steel frames that do not have factory installed mounting tabs for electric strike installation.

1. Prepare the frame as shown on page 2. Fasten the mounting tabs to the faceplate of the strike, selecting the appropriate shims for your installation.
2. Using the assembled strike and tabs as a template, place against the frame and mark the mounting hole locations. Remove and drill two 3/16" holes in the frame for each mounting tab and countersink the frame.
3. Remove the tabs from the faceplate and install in the frame using the 12-24 x 3/8" machine screws supplied. Tabs are zinc plated and drilled and tapped for this purpose.
4. Make final electrical connections per page 2 and mount strike to the tabs with the 12-24 x 3/8" machine screws.

