

CS 80 Magneo Sliding Door Operator Cavity Frame System



Advantages at a glance

- Compact automatic sliding door operator with Magnetic Drive Technology.
- German designed & manufactured.
- In wall 92mm aluminium cavity frame available in 3 different sizes.
- Integrates with interior sliding doors up to max 80kg.
- Smooth & quiet operation offering an enhanced user experience.
- Low energy mode for extra sensitive operation.
- Contactless door activation.
- Push & Go function.

dormakaba stands for reliability, security and highest quality.

The CS 80 Magneo operator with a cavity frame perfectly integrates into the architecture of a building to meet the high aesthetic requirements of interior door design.

Utilising the latest in magnetic drive technology, the CS 80 Magneo operator is almost silent during operation, making it especially suitable for areas where a low noise level is essential.

The CS 80 Magneo operator offers a wide variety of application options in both residential and commercial buildings.

Magnetic Drive Technology, virtually silent during operation.

The CS 80 Magneo Operator is driven magnetically by a contactless shear wave from a linear DC motor, a movement that perfectly matches that of a sliding door.

The functional principle of MAGNEO

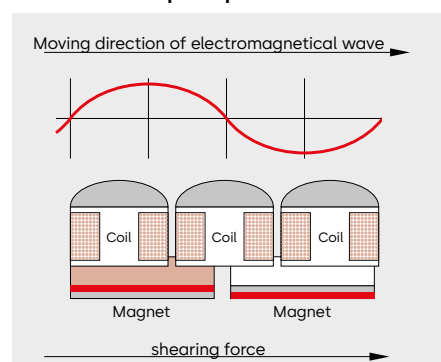

In Wall Cavity Frame System

The In-wall cavity frame system fits in a standard 92mm wall space and is available in 3 different door width sizes.



- Frame LV1 1950mm Material No. 9400000016411
- Frame LV2 2200mm Material No. 9400000016734
- Frame LV3 2450mm Material No. 9400000016412

Technical details

AUTOMATIC CAVITY SLIDING DOOR - CS80 MAGNEO - RIGHT HAND SINGLE LEAF - TIMBER DOOR

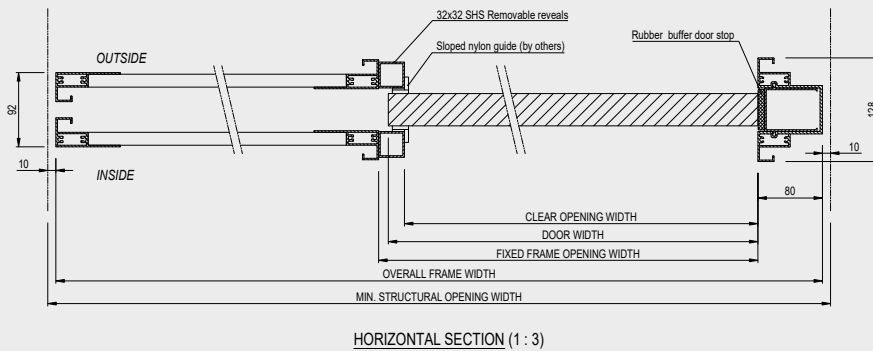
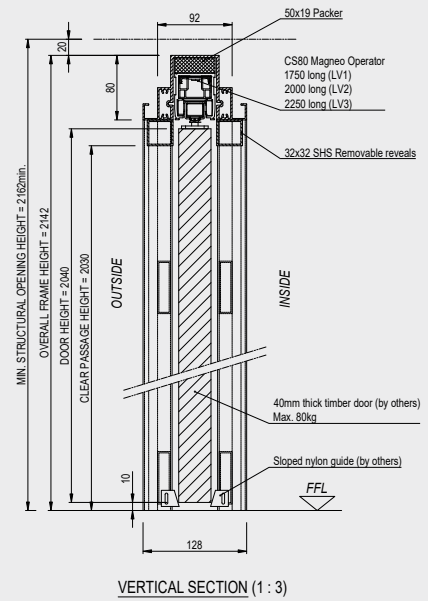
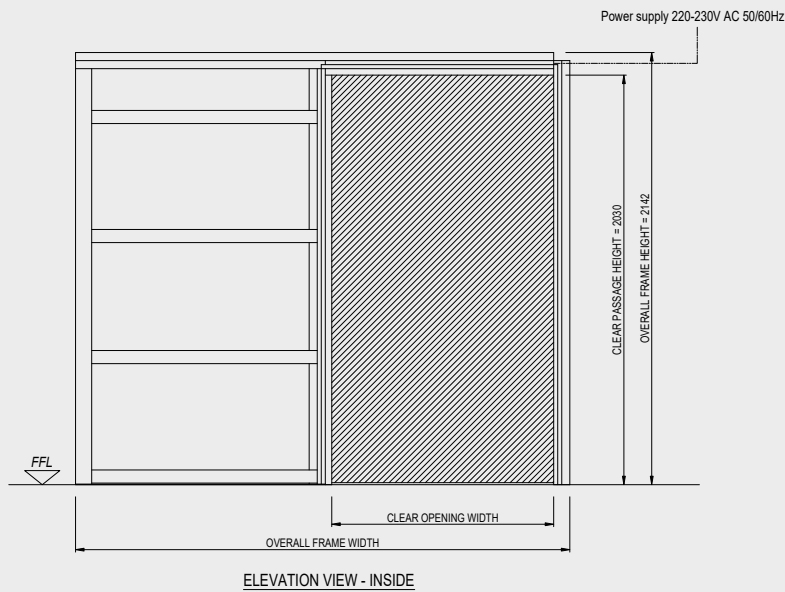

Accessories



9003 Touchless activation switch

Material no. 9400000011759 (white)

Material no. 9400000011758 (black)



Single button wireless remote wall switch

Material no. 29301005



Transmitter key chain wireless remote

Material no. 29304001

Technical specifications

	CS 80 Magneo LV1	CS 80 Magneo LV2	CS 80 Magneo
Clear Opening Width	850mm	975mm	1100mm
Door Width	870mm	995mm	1120mm
Overall Frame Width	1950mm	2200mm	2450mm
Min Structural Opening Width	1970mm	2220mm	2470mm
Min Structural Opening Height	2162mm	2162mm	2162mm

Please note: If handles are to be fitted, the clear opening width will be reduced by (120mm + door handle thickness) for DDA compliance.

Please note: The range of functions of the product depends on the system environment chosen. For further details and order information, please check the relevant dormakaba catalogue or system description.

Any questions? We would be happy to advise you.