

Installation Instructions

8000 Series Pull Trim

CYLINDER SPECIFICATIONS AND INSTALLATION

NOTE:
TAILPIECE WILL HAVE TO BE
SHORTENED; 1/8" (3mm)
- 3/16" (5mm) LESS THAN
THICKNESS OF DOOR.

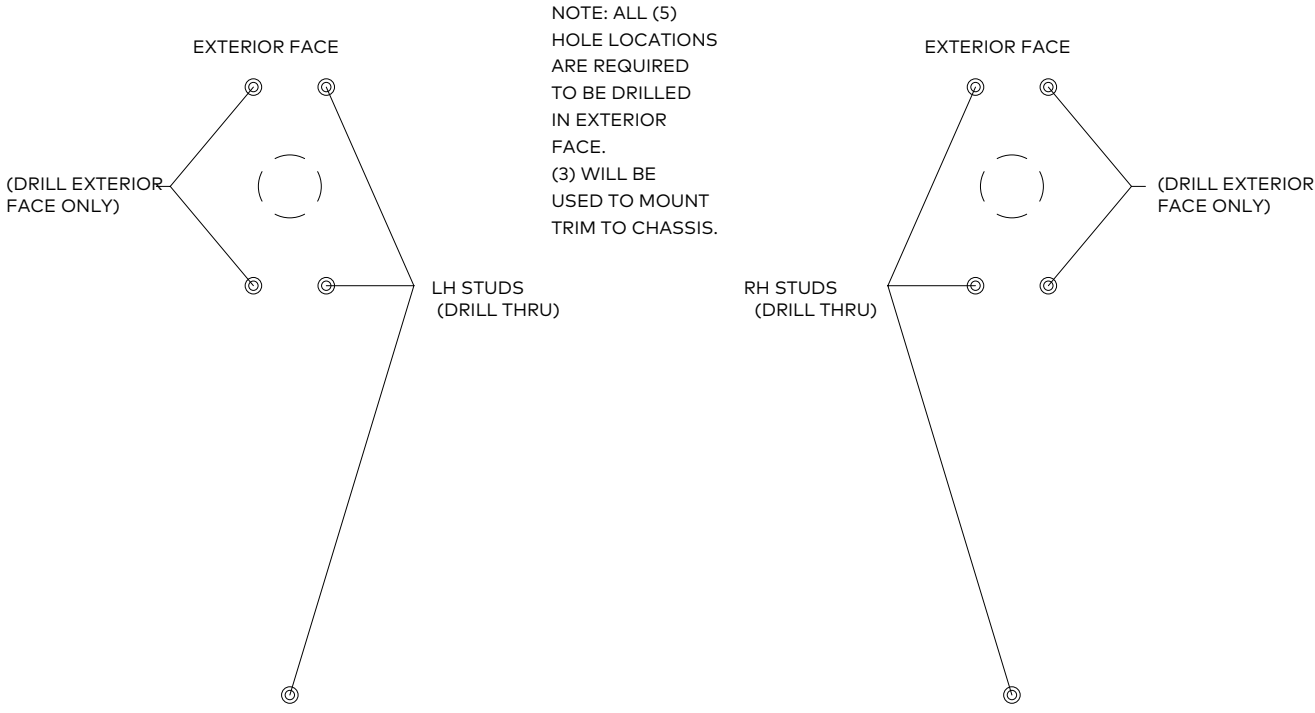
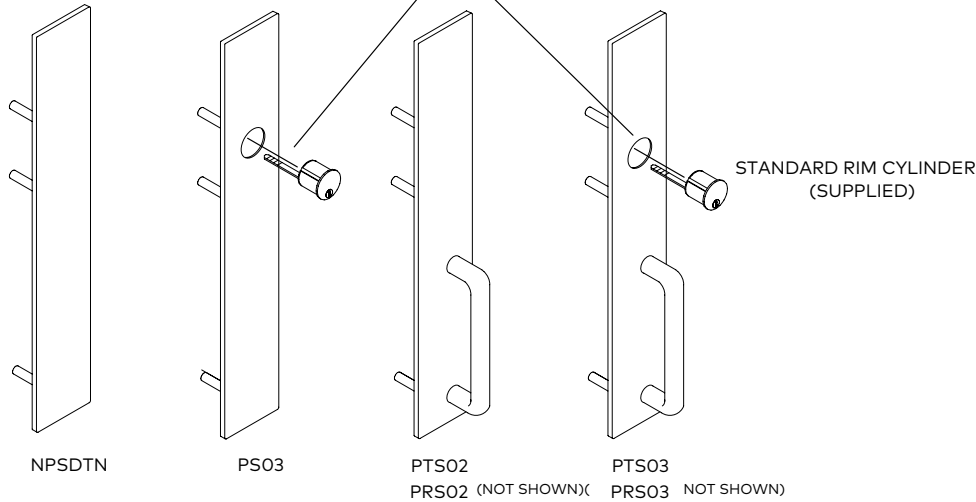

Installation Instructions

8000 Series Pull Trim

CYLINDER SPECIFICATIONS AND INSTALLATION

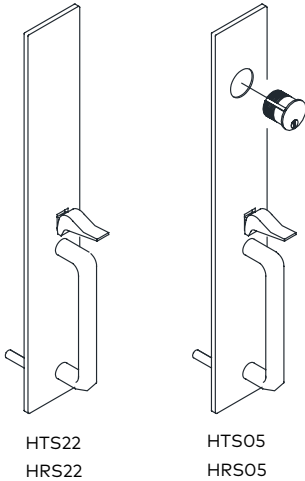

Note: Trim handing change only required for use with 8400 series device.

For handing of 8400 chassis see device instructions.

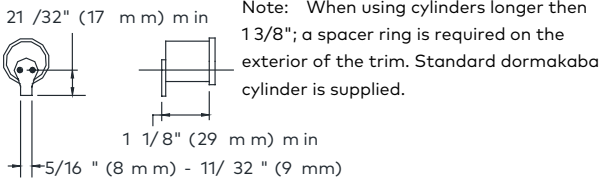

Note: When using cylinders longer than 1 3/8"; a spacer ring is required on the exterior of the trim. Standard dormakaba cylinder is supplied.

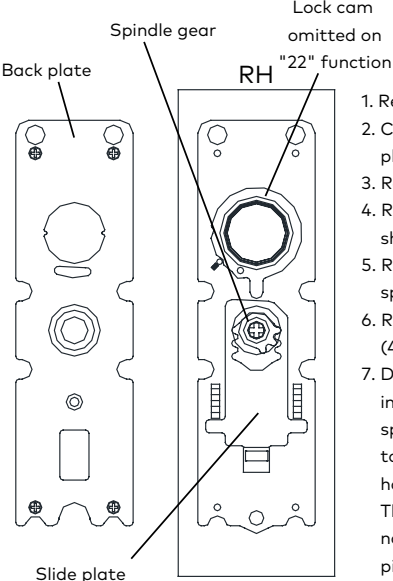

1. Remove backplate.
2. Carefully remove (2) slide plate springs.
3. Remove slide plate.
4. Rotate spindle gear as shown for opposite hand.
5. Re-install slide plate and springs as shown.
6. Re-install back plate with (4) screws.
7. Drive small pin out of inner spindle, rotate inner spindle to allow cross hair to align both vertical and horizontal as shown. (Note: The timing will be off if this not done. Re insert drive pin.

Note: Use caution not to loose small detent ball or spring when changing hands.

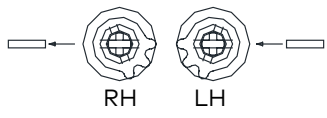
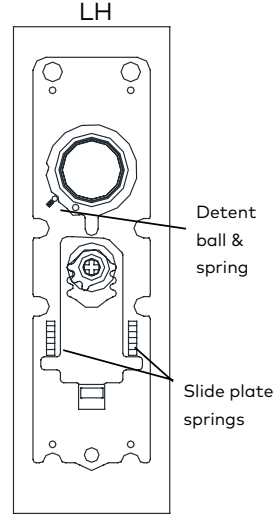

"06" Function

Insert mortise cylinder through trim, then install "09" cam as shown, placing notch of cam over or around actuator pin in rear of trim then install cylinder nut.

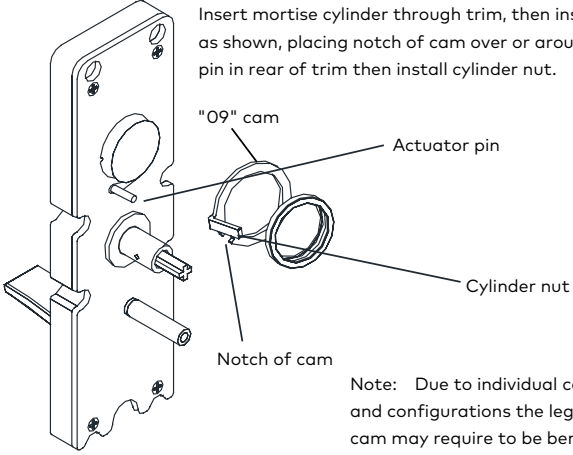

Note: Due to individual cam styles and configurations the leg of the "09" cam may require to be bent slightly to function properly. Always try trim in hand for proper function prior to installing in door.

Trim shipped standard for 1 3/4" thick doors. For 2" - 2 1/4" thick doors inner spindle requires to be lengthened as shown. For 2" thick doors inner spindle will also require to be cut down 1/4".

