

Ilco Front Desk Unit (FDU)



Security features

- Time-based access control system with user selectable keycard expiry
- Keycard encryption: proprietary and unique to each installation
- Security: authorization keycard or PIN required for any FDU operation
- Different authorization levels, ranging from front desk staff to upper management users
- Setup and audit memory: internal real time clock with non-volatile memory

Overview

The FDU is an all-in-one portable device that encodes keycards and programs & audits electronic locks without the need for a separate computer or any IT infrastructure. With an 8 hour battery backup, the FDU can continue to manage the system even during a power failure. The FDU is ideal for small to mid-scale hotels seeking a simple and cost effective solution for managing their door locking system.

Compatibility

Compatible with 700-II, Solitaire 710/710-II, Generation E-760, 770 and 790 locks

System features

- **Property size:** 16,000 rooms and 1,000 common door suites (maximum of 8 inner doors per suite)
- **Common areas:** 8 guest and 16 staff areas
- **Restricted Areas:** 200
- **Staff access levels:** 3 Master levels and 5 Sub-Master levels per lock: 255 sections, floors, areas, groups, zones
- **Room number** Format: 5 digits numeric
- **Keycards Validity** Selectable: From one hour to 7 years
- **Pre-registered guest:** Keycards can be made up to 10 days in advance
- **Time zone:** Predefined time zones available for staff keycards in locks
8 customer defined time zones available for guest, staff & passage option in RAC card readers

- **Keycards read and encoded:** Low or high coercivity, track 1, 2 or 3 magnetic stripe cards and Mifare credentials
- **Keycard handling:** Manual swipe with wide acceptable speed range for magnetic stripe keycard
- **Communication ports:** Serial and USB, for Flash drive and Kaba USB printer
- **Communication with locks:** Programming module
- **Communication with other FDUs, PMS interface:** Serial cable
- **Firmware:** Upgradeable, via USB

FDU Characteristics

Mode of operation	Encoder for Front Desk or back-of-house (optionally interfaced to PMS), portable Lock Maintenance Unit
Power supply	9V plug-in power supply available for North America, European, U.K. and Australia
Battery backup	Internal, minimum 8-hour duration (unit fully operable) with low battery alarm
Languages	English, French, Spanish, Portuguese, German
Audits	Last 4000 keycard-making transactions, sorted by room, authorization, or key type The FDU can store up to 10 lock audits in memory Either type of audit (lock and FDU log) can be reviewed on screen, shared on a PC or printed for record keeping on any standard printer

Physical characteristics

Weight	2 Lbs (0.9Kg)
Dimensions	7.2 (W) X 9.5 (L) X 2.2 (H) inches (180 X 240 X 57 mm)
Housing construction	Impact resistant plastic (black), with rubber feet and carrying handles

Environmental operating conditions

Certifications, approvals and testing	1,000,000 swipe life expectancy Complies with FCC part 15 class A Complies with the EMC directives 89/336/EEC, CE certified
--	---

Warranty

Standard factory warranty	Two years
Extended warranty	ILCO Service Plans (Platinum, Gold, Silver)

Dimensions

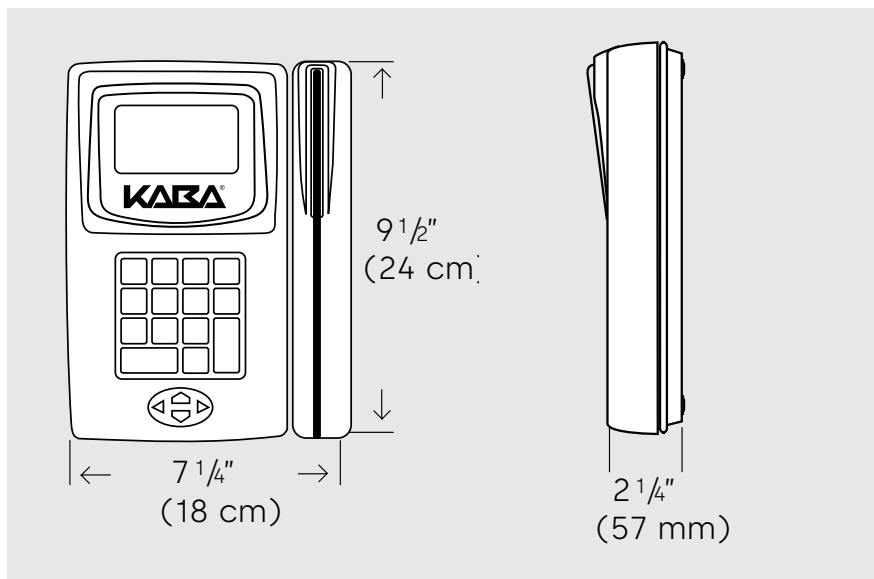

© dormakaba 2024 Information on this sheet is intended for general use only. dormakaba reserves the right to alter designs and specifications without notice or obligation.

Any questions? We would be happy to advise you.

Contact us at: 1.800.999.6213