

### F Note importante

1. La tension d'alimentation doit être suffisante. Voir la notice de raccordement
2. Sélectionner la tension d'alimentation **AVANT** de mettre le verrouillage sous tension
3. Ne jamais percer ni modifier la ventouse et la contre plaque

1. The power supply has to be enough for the electromagnet. Look at wiring notice
2. Select the voltage 12 or 24 V DC **BEFORE** the voltage is applied
3. The armature plate and the electromagnet should no be drilled or modified

**Important notice** **GB**

### F Installation type sur une porte en aluminium

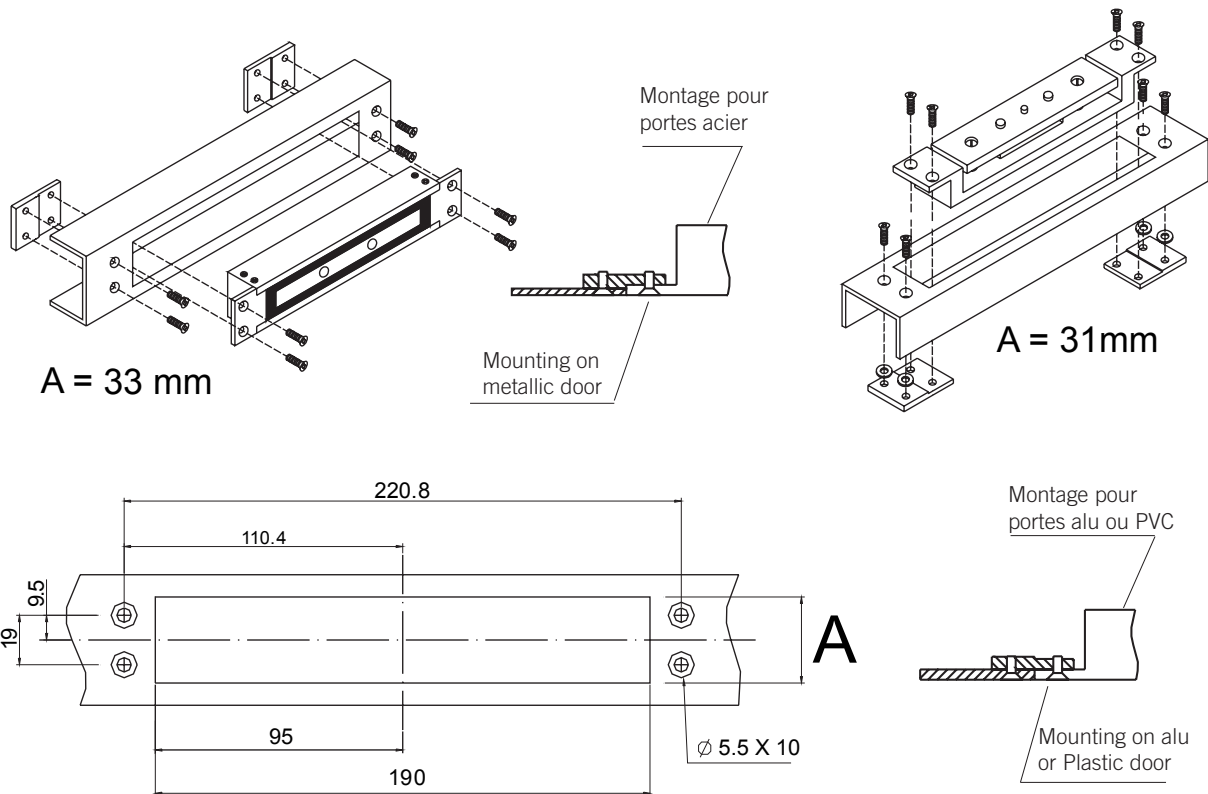

**Typical installation for aluminium door** **GB**

## F Installation type sur une porte en bois

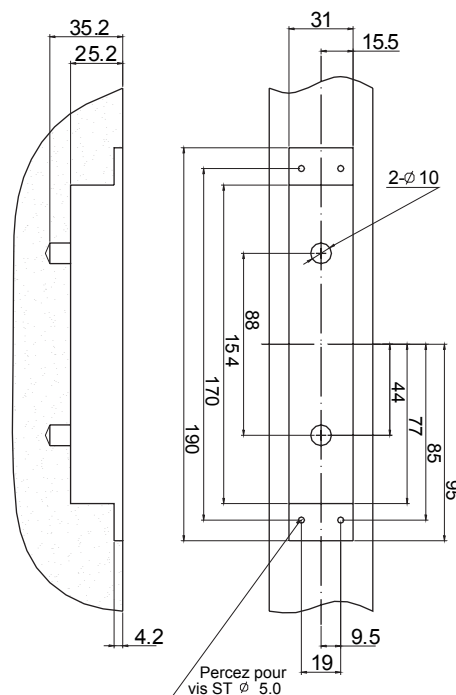
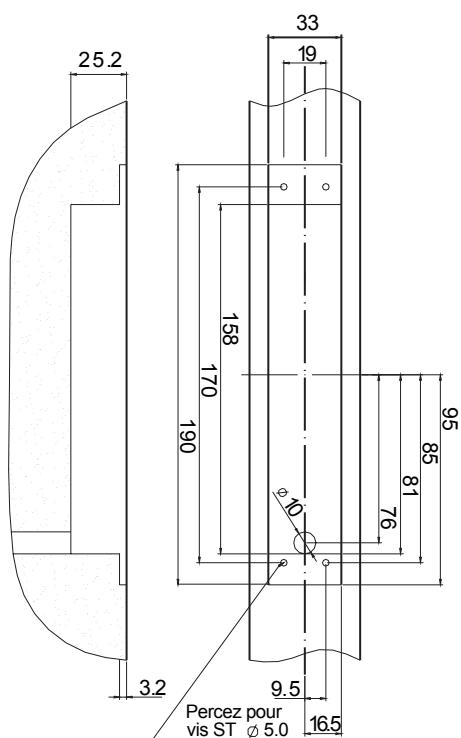
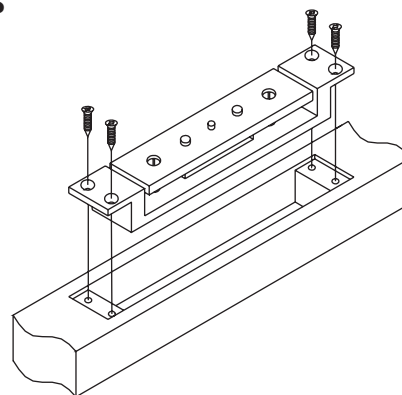
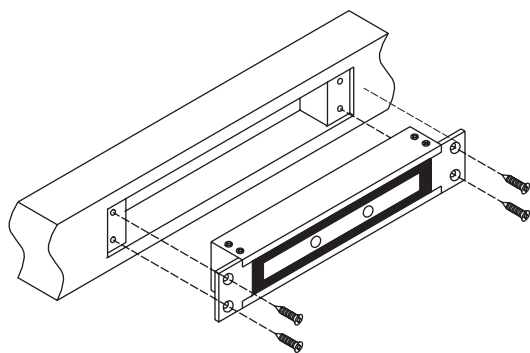

Typical installation for wooden door **(GB)**

## F Réglages après la pose

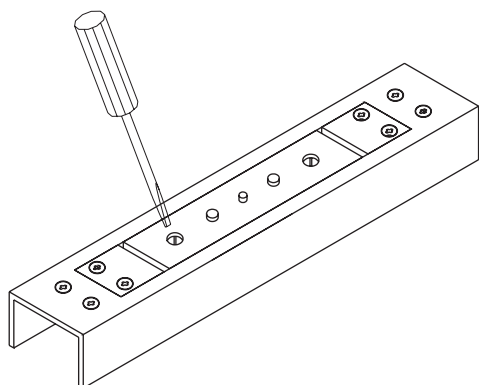

Après montage, ajuster les vis pour s'assurer d'un intervalle de 3 mm comme dessiné ci dessous

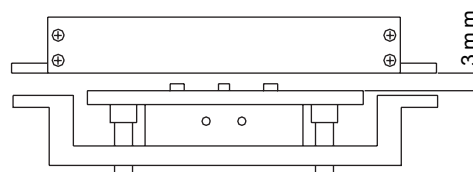

After mounting, adjust screws to make sure the gap is 3 mm as drawing above

Adjust after mounting **(GB)**