

EM 500

Electric magnets



The modular system to hold open fire and smoke doors

In response to customer demands, dormakaba completes its technically and aesthetically pioneering product range for fire and smoke doors with its EM models. The new developments stand out due to their ease of installation and functional elegance. The guaranteed quality ensures highest reliability and a long service life.

The production plant is ISO 9001 certified.

Benefits – point by point

For trade

- Economical system solution thanks to low stock keeping with maximum flexibility
- Another module in the dormakaba product range, i.e. all from one provider

For installers

- Quick and easy installation
- Thought-through accessories for the most varied applications

For planners

- Uniform appearance for all versions
- Modular system for flexible applications

For the end user

- Unobtrusive appearance.
- Concealed cable entry
- Optimal holding force with low power consumption

Daten und Merkmale		500 G	500 U	500 A
Installation	Surface-mounted	●	–	●
	Flush-mounted Floor ¹⁾	–	●	–
Holding force	400 N	●	●	●
Anti-remance pin		●	●	●
Test pushbutton		–	–	●
Polarity reversal protection		●	●	●
Operating voltage 24 V AC/DC		●	●	●
Max. power consumption in W			1.5	
On-load factor in %			100	
Degree of protection			IP 40 ²⁾	
Ambient temperature in °C			0 – 50	
Weight in kg		0.41	0.42	0.46
Dimensions in mm	Width	85	85	85
	Length	85	85	85
	Depth	32	35	35
Hold-open system tested in accordance with EN 1155			●	
CE -Identification for construction products			●	

● Yes – No

¹⁾ In conjunction with floor bracket (accessory)

²⁾ EM 500 A in conjunction with floor bracket of protection class IP 43

Electric magnets

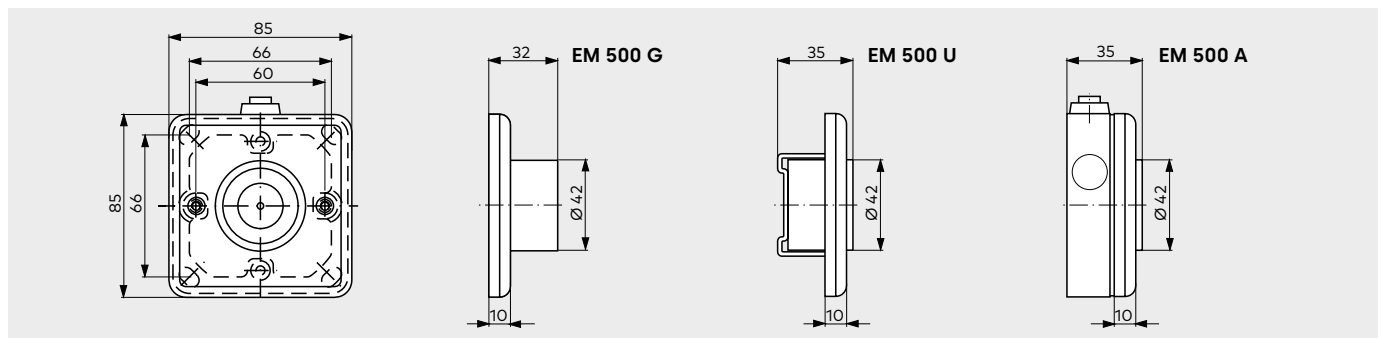

Anchor

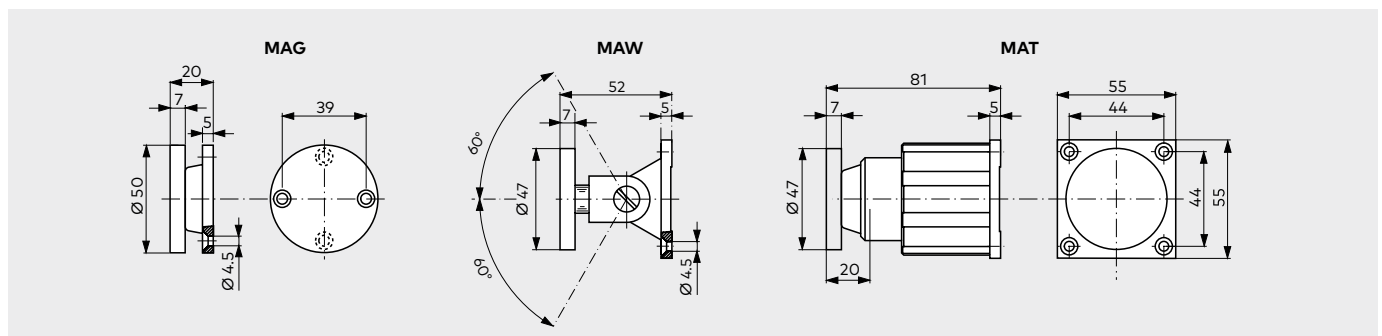

Electromagnets for use in hold-open systems

According to legal regulations, fire and smoke doors that are kept open for a limited period of time must be outfitted with hold-open systems to enable the door leaves or gates to close automatically in the event of a fire.

Hold-open systems consist of a hold-open device, fire detector, power supply and trigger element and must be approved by the Deutsches Institut für Bautechnik (DIBt), Berlin (Germany).

Electric magnets are hold-open systems that keep fire protection terminals and smoke doors open.

In case of fire, the trigger element disconnects the hold-open system as soon as the fire detector recognizes the fire. Automatic closing is achieved through the use of quality-monitored door closers that comply with EN 1154.

It must also be possible to activate the hold-open function by hand. According to the regulations for hold-open systems, a manual release pushbutton is required for this purpose when electric magnets are used. The button used for this purpose must be red, carry the lettering "Close door", be directly next to the door and must not be covered by the door when opened.

Application examples

TS 93 EMR (without EMF)

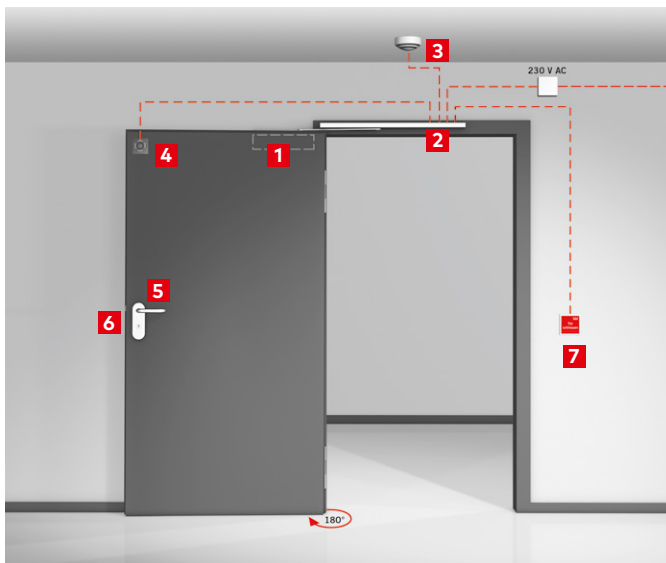

- 1 1 TS 93 door closer
- 2 1 G-EMR slide channel without EMF
- 3 2 RM-N smoke detectors
- 4 1 Magnetic clamp e.g. EM 500
- 5 1 OGRO FP lever handle
- 6 1 FP lock
- 7 HT manual release pushbutton

TS 93 ESR EMR (without EMF)

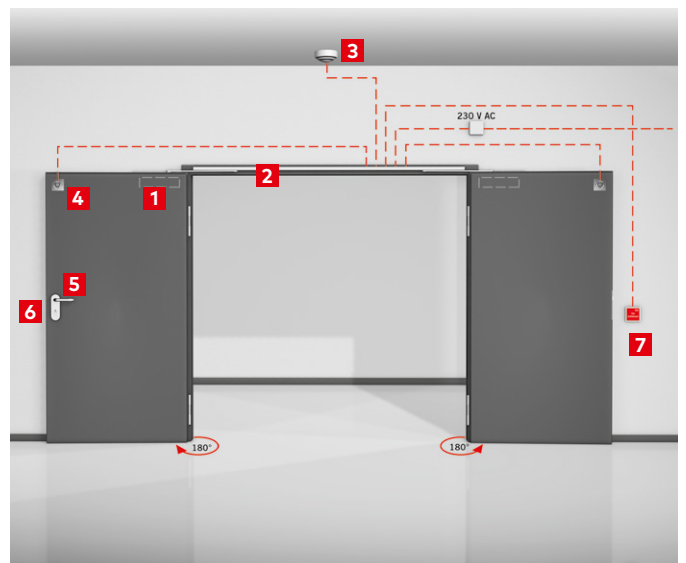

- 1 2 TS 93 door closers
- 2 1 GSR-EMR slide channel without EMF
- 3 2 RM-N smoke detectors
- 4 Magnetic clamps e.g. 2 x EM 500
- 5 1 OGRO FP lever handle
- 6 1 FP lock
- 7 HT manual release pushbutton

F Certificate of suitability

EM 500 series electromagnets for 24 V AC/DC are approved by the Deutsches Institut für Bautechnik (DIBt), Berlin (Germany), for use with the RMZ smoke detection system and other well-known smoke detection systems (e.g. with RMZ: approval no. Z-6.500-2372); approval of the hold-open system is also required.

The modular system at a glance

EM 500 G

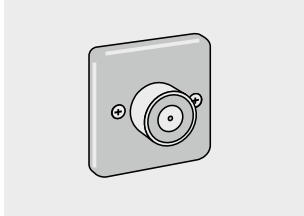

EM 500 U

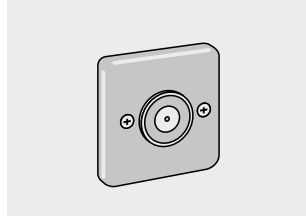

EM 500 A

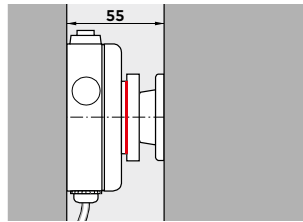
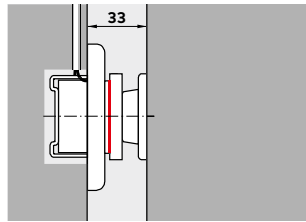
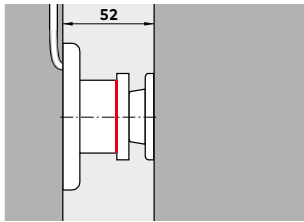
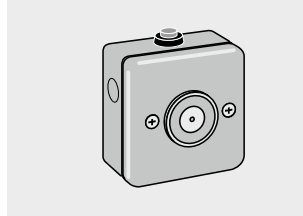

MAG

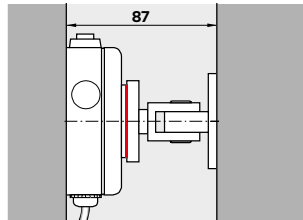
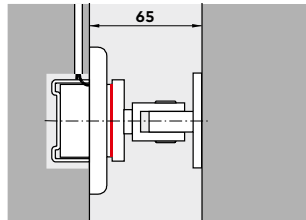
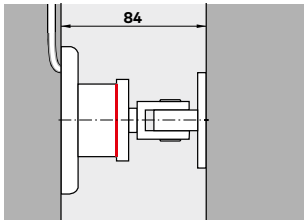
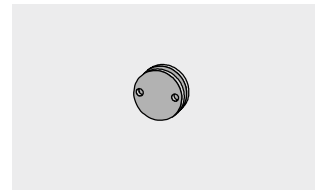

MAW

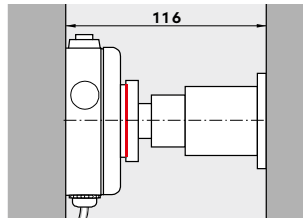
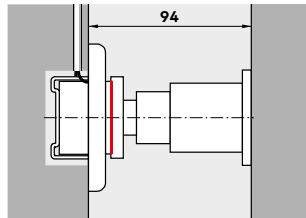
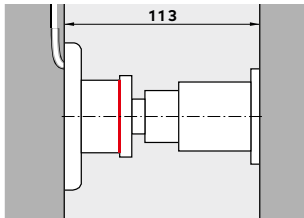
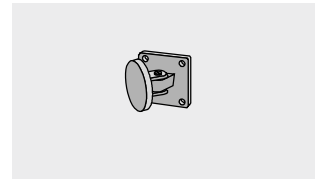

MAT

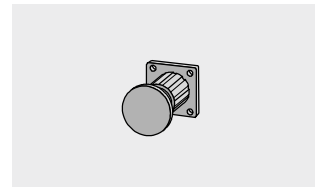

Specification text

EM 500 G

Electromagnet with reverse polarity protection for wall and floor mounting*.

Holding force 400 N

24 V AC/DC

Approved by the Deutsches Institut für Bautechnik (DIBt), Berlin (Germany), for use in hold-open systems.

Acceptance inspection required.

Required accessories: Anchor

Make

dormakaba EM 500 G

M 500 U

Electromagnet with reverse polarity protection for flush mounting.

Holding force 400 N

24 V AC/DC

Approved by the Deutsches Institut für Bautechnik (DIBt), Berlin (Germany), for use in hold-open systems.

Acceptance inspection required.

Required accessories: Anchor

Make

dormakaba EM 500 U

EM 500 A

Electromagnet with reverse polarity protection and test pushbutton for wall and floor mounting*.

Holding force 400 N

24 V AC/DC

Approved by the Deutsches Institut für Bautechnik (DIBt), Berlin (Germany), for use in hold-open systems.

Acceptance inspection required.

Required accessories: Anchor

Make

dormakaba EM 500 A

* In conjunction with floor bracket, see page 5

Accessories

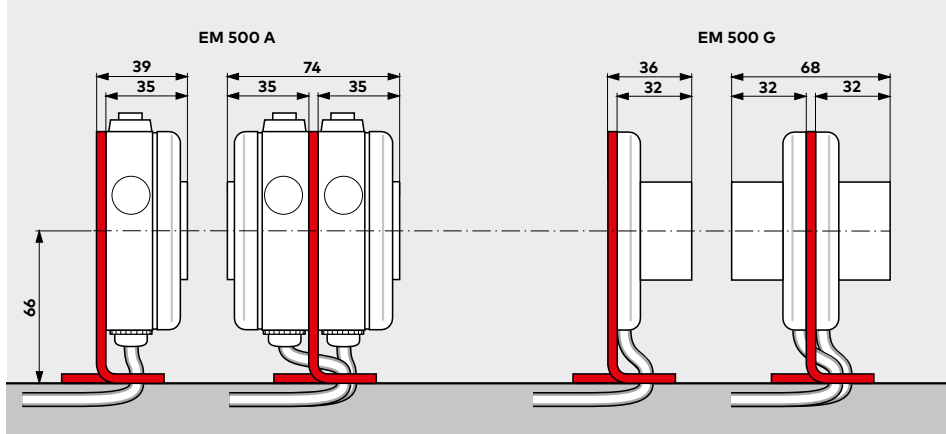

For the use of electromagnets EM 500 G and EM 500 A for floor mounting.

An electromagnet for floor mounting EM 500 B consists of an electromagnet EM 500 G or EM 500 A and the floor bracket. For tender texts see page 4.

Floor bracket

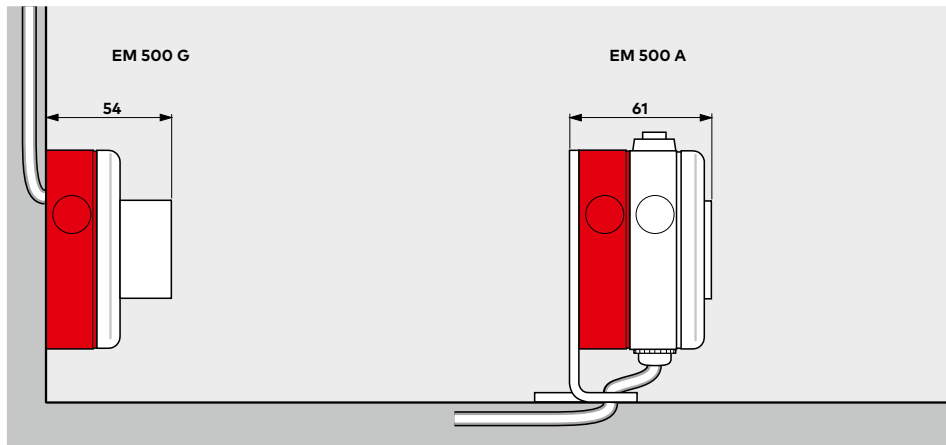
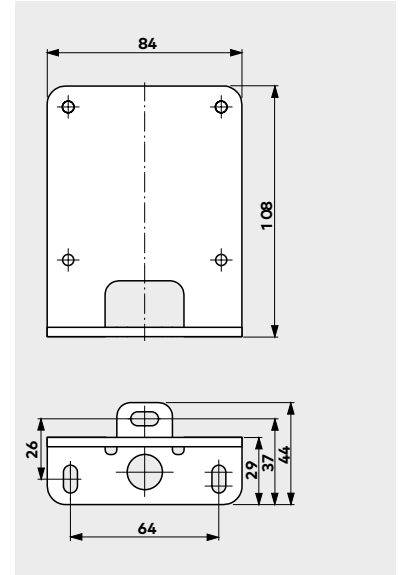

The frame can be combined with the electromagnets of the EM 500 G/U/A series.

Adapter frame

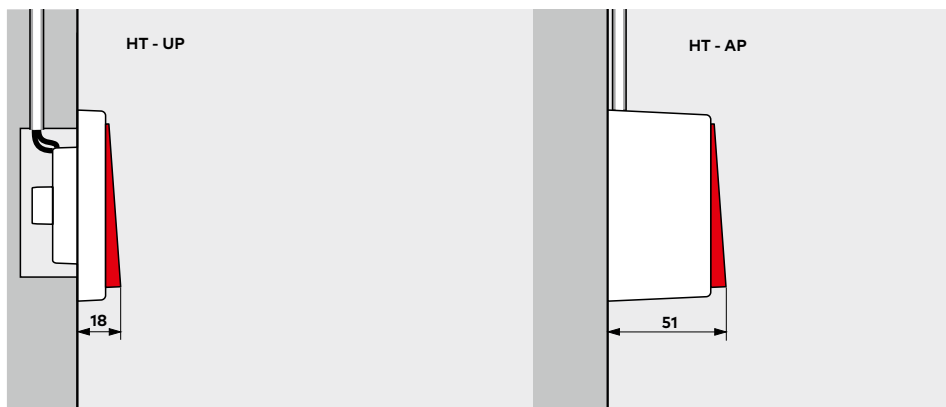
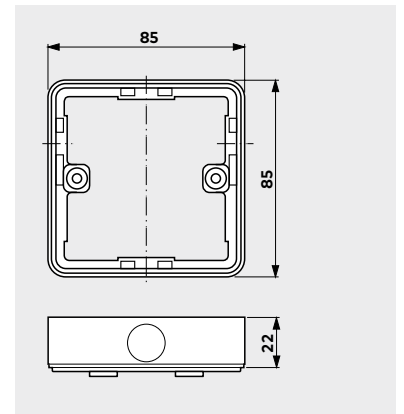

To manually trigger the hold-open.

When electromagnets are used in hold-open systems on fire and smoke protection doors, a manual release switch is required according to the guidelines of the Deutsches Institut für Bautechnik (DIBt), Berlin (Germany).

Manual release switch

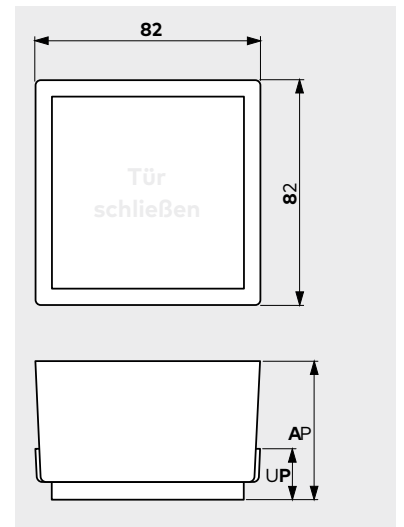

EM 500 H special version for floor, ceiling and wall mounting with test pushbutton

EM 500 H 150/175 mm

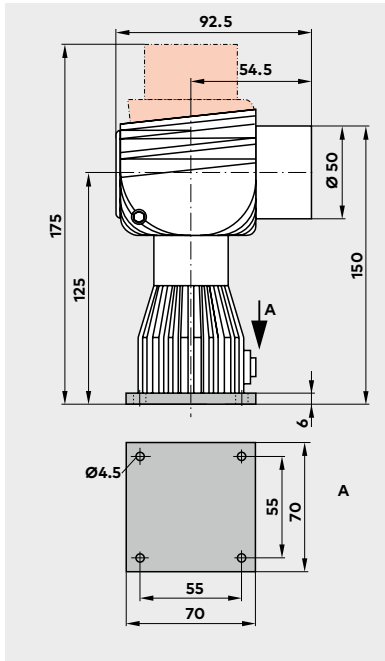

EM 500 H 300/325 mm
EM 500 H 450/475 mm

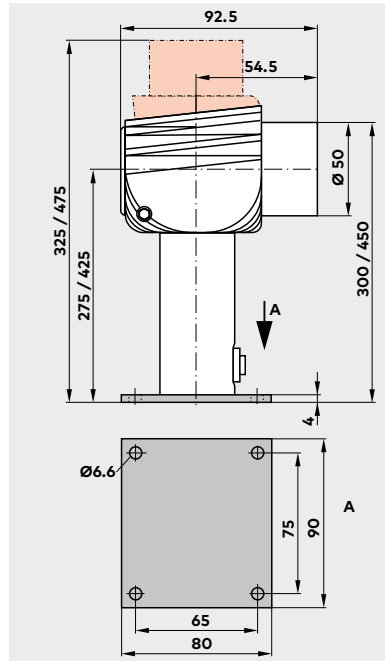

MAG1

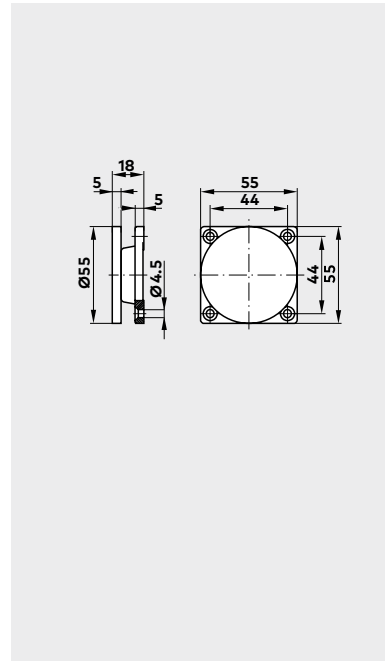

Specification text

24 V DC electromagnet with reverse polarity protection for floor, ceiling and wall mounting with test pushbutton.

Holding force 490 N.

Approved by the Deutsches Institut für Bautechnik (DIBt), Berlin (Germany), for use in hold-open systems.

Acceptance inspection required.

Version

- 150/175 mm
- 300/325 mm
- 450/475 mm

Required accessories

- Anchor MAG

Make





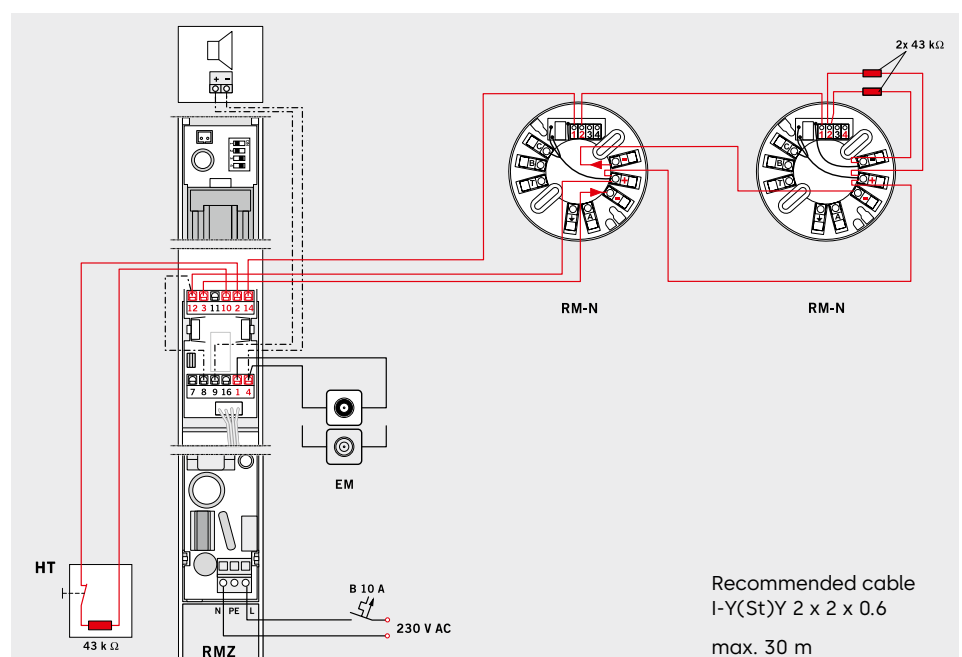



dormakaba EM 500 H

EM + RMZ + 2x RM-N



Recommended cable
I-Y(St)Y 2 x 2 x 0.6
max. 30 m

Product contents and accessories

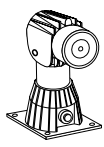
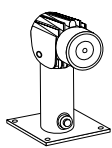
		MAG	MAW	MAT	MAG I	Floor bracket	Adapter frame
							
		□ 69020110	□ 69020111	□ 69020112	□ 69021113	69011540	690xx541
EM 500 G 	24 V AC/DC ■ 690xx511	■ □	■ □	■ □		△	△
EM 500 U 	24 V AC/DC ■ 690xx521	■ □	■ □	■ □			△
EM 500 A 	24 V AC/DC ■ 690xx531	■ □	■ □	■ □		△	△
EM 500 H 24 V DC 	150/175 mm ■ 69015005				■ □		
EM 500 H 24 V DC 	300/325 mm ■ 69015006				■ □		
	450/475 mm ■ 69015007				■ □		

Manual release switch

UP switch 19144601175



AP switch 19144601175 +
5158533332



xx Colour

11 White (RAL 9016)
12 Stainless-steel finish

- Separate electromagnet
- Separate anchor
- △ Accessories

Note

An electromagnet for floor mounting consists of an EM 500 G or EM 500 A electromagnet and the floor bracket.

Our Sustainability Commitment

We are committed to foster a sustainable development along our entire value chain in line with our economic, environmental and social responsibilities toward current and future generations. Sustainability at product level is an important, future-oriented approach in the field of construction. In order to give quantified disclosures of a product's environmental impact through its entire life cycle, dormakaba provides Environmental Product Declarations (EPD), based on holistic life cycle assessments.

www.dormakaba.com/sustainability



Our offering

Access Automation Solutions

Entrance Automation
Entrance Security



Access Control Solutions

Electronic Access & Data
Escape and Rescue Systems
Lodging Systems



Access Hardware Solutions

Door Closers
Architectural Hardware
Mechanical Key Systems



Services

Technical Support
Installation and commissioning
Maintenance and Repair



WN 05136451532, EN, 05/2023
Subject to technical modifications.



dormakaba.com

dormakaba
International Holding AG
Hofwissenstrasse 24
CH-8153 Rümlang
T +41 44 818 90 11
info@dormakaba.com
dormakaba.com