

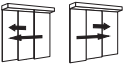

WN 059438 45532, 2019-07

LH <sup>max</sup> : 3 000 mm			
	<b>ES 200 EASY</b>	<b>ES 200</b>	<b>ES 200 2D</b>
	m = 2 x 50 kg LW: 800 - 2400 mm	m = 2 x 75 kg LW: 800 - 2400 mm	m = 2 x 75 kg LW: 1000 - 2400 mm
	m = 4 x 43 kg LW: 1400 - 4000 mm	m = 4 x 75 kg LW: 1400 - 4000 mm	m = 4 x 65 kg LW: 1400 - 4000 mm



**Inhaltsverzeichnis**

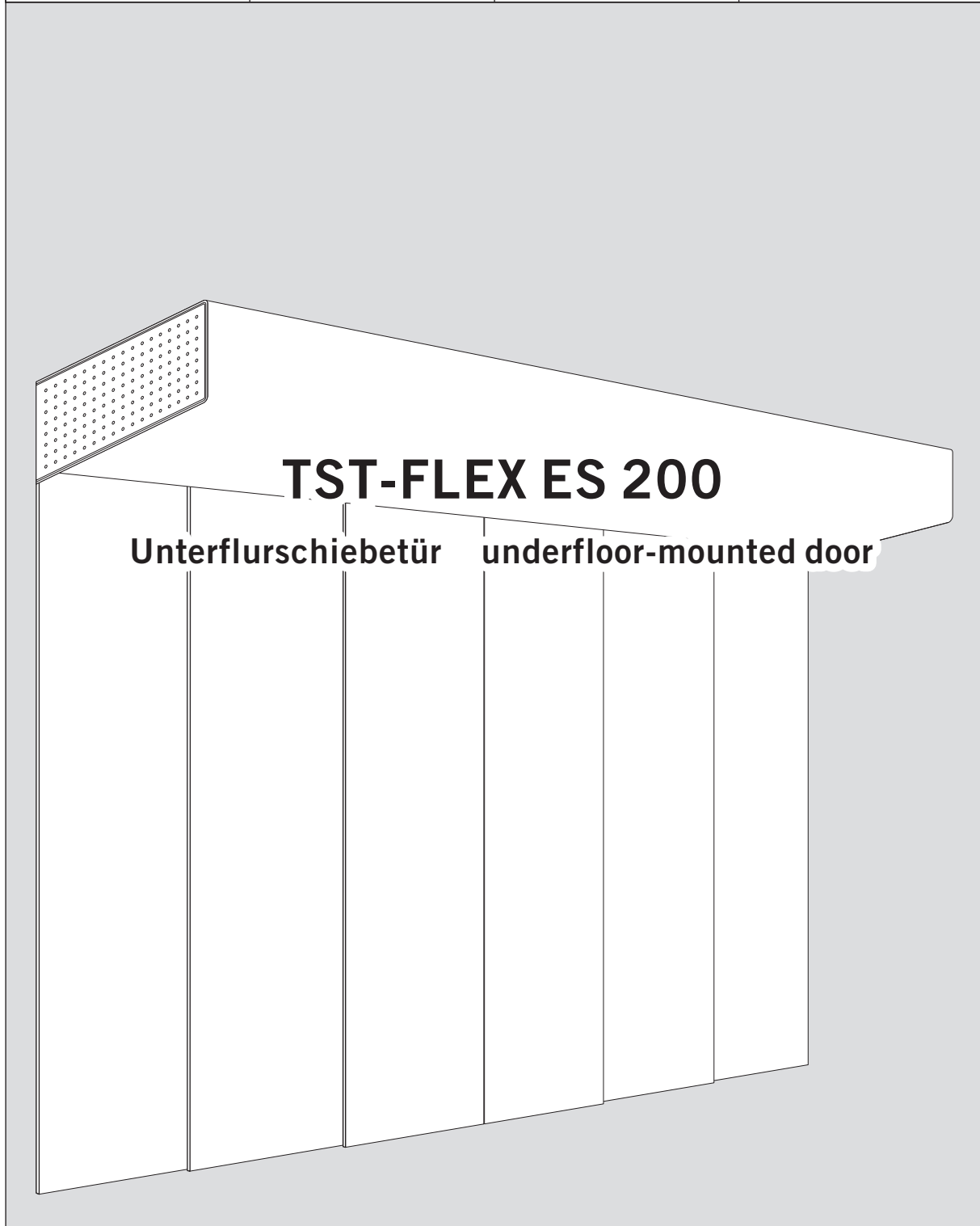





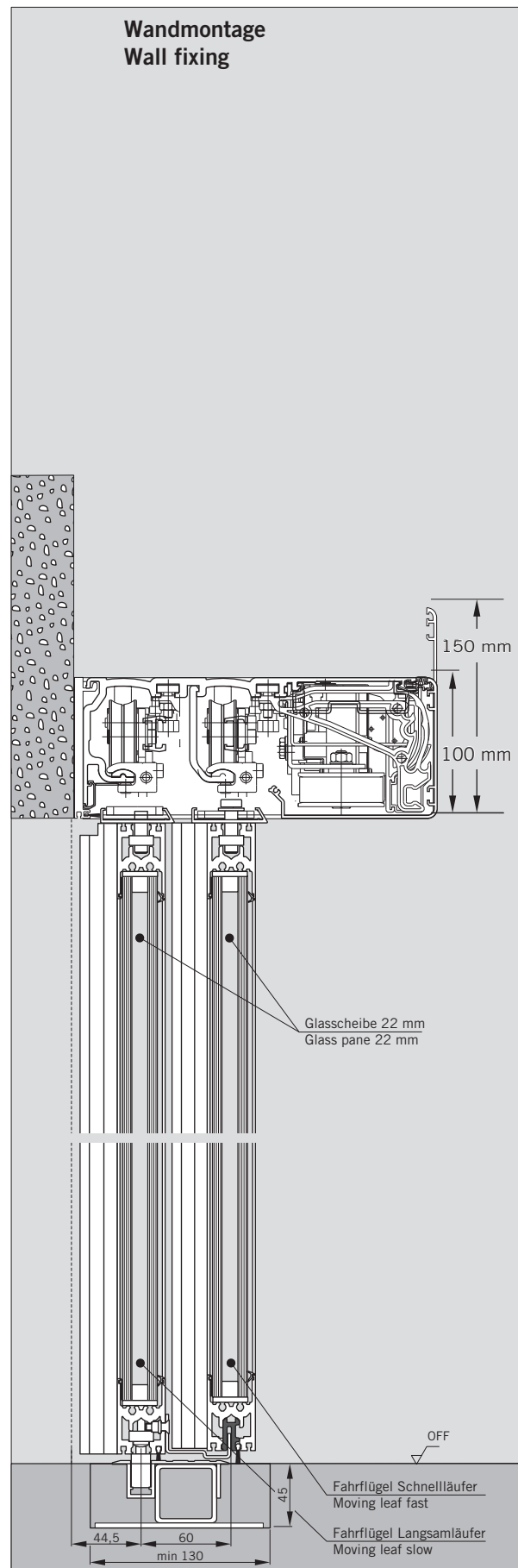
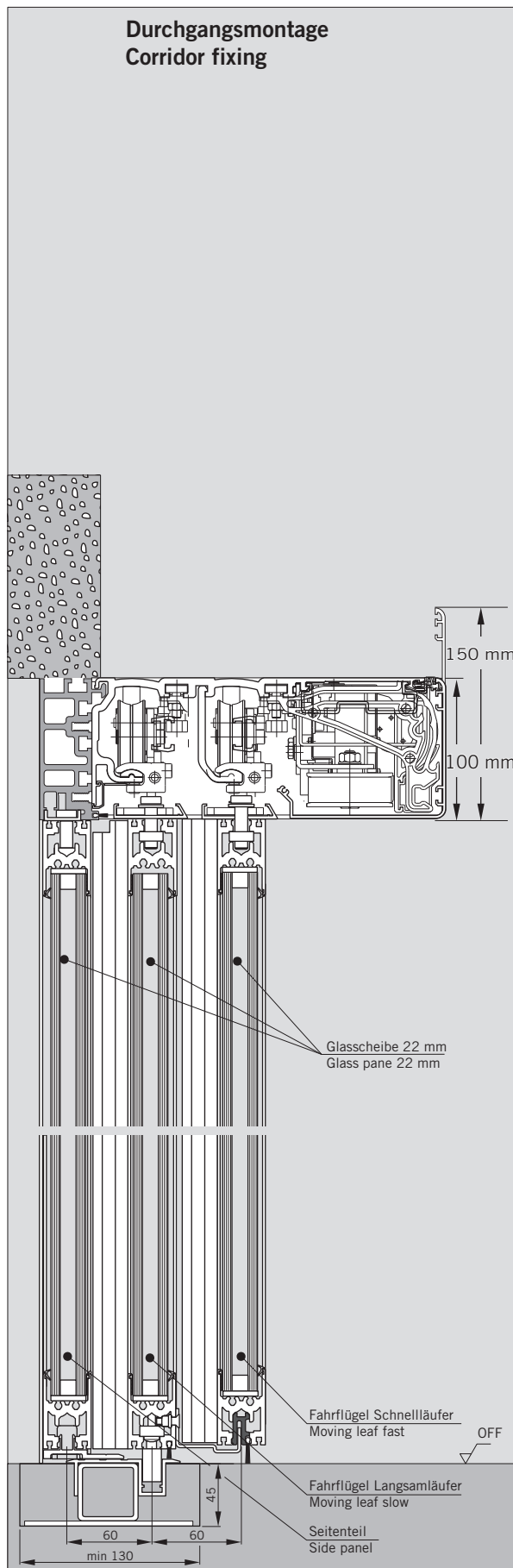

	<b>Seite</b>
Inhaltsverzeichnis .....	02
Übersicht Schnittzeichnungen .....	03
<b>Fahrflügel Schnellläufer</b>	
Benötigte Profile und Zubehör .....	04 - 05
Übersichtszeichnung des Fahrflügels .....	06
Bearbeitungszeichnungen der Profile .....	07
<b>Fahrflügel Langsamläufer</b>	
Benötigte Profile und Zubehör .....	08 - 09
Übersichtszeichnung des Fahrflügels .....	10
Bearbeitungszeichnungen der Profile .....	11
<b>Seitenteil</b>	
Benötigte Profile und Zubehör .....	12 - 13
Übersichtszeichnung des Seitenteils .....	14
Bearbeitungszeichnungen der Profile .....	15 - 16
<b>Wandanbindung der Anlage ohne Seitenteil</b>	
Benötigte Profile und Zubehör .....	17/18
Übersichtszeichnung der Anbindung .....	17/18
Bearbeitungszeichnungen der Profile .....	17/19
<b>Oberlicht</b>	
Benötigte Profile und Zubehör .....	20 - 21
Übersichtszeichnung des Oberlichts .....	22
Bearbeitungszeichnungen der Profile .....	23
<b>Unterflurschiene</b>	
Übersichtszeichnung der Unterflurschiene .....	24
Bearbeitungszeichnungen der Profile .....	25

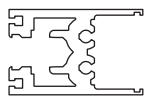
**Contents**

	<b>Side</b>
Contents .....	02
Overview cutaway .....	03
<b>Moving leaf fast</b>	
Profiles and accessories which are required .....	04 - 05
Overview drawing of the moving leaf .....	06
Detail drawings of the profiles .....	07
<b>Moving leaf slow</b>	
Profiles and accessories which are required .....	08 - 09
Overview drawing of the moving leaf .....	10
Detail drawings of the profiles .....	11
<b>Side panel</b>	
Profiles and accessories which are required .....	12 - 13
Overview drawing of the side panel .....	14
Detail drawings of the profiles .....	15 - 16
<b>Connection to the wall without side panel</b>	
Profiles and accessories which are required .....	17/18
Overview drawing of the Connection to the wall .....	17/18
Detail drawings of the profiles .....	17/19
<b>Transom light</b>	
Profiles and accessories which are required .....	20 - 21
Overview drawing of the transom light .....	22
Detail drawings of the profiles .....	23
<b>Floor guide</b>	
Overview drawing of the Floor guide .....	24
Detail drawings of the profiles .....	25

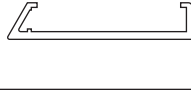

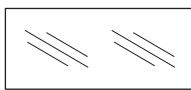

TST-FLEX ES 200  
 Fahrflügel Schnellläufer  
 Moving leaf fast

A		B		St. pc.
Profile/Zubehör Profils/accessories	Artikelnummer Article-number	Bezeichnung Name	Zuschnittsformel Cutting Formula	
	325 408-XX-1-20 01 - 6250mm roh / mill finish 02 - 6250mm E6 / CO 06 - 4250mm roh / mill finish 07 - 4250mm E6 / CO	Horizontalprofil horizontal profile	<b>A</b> $L = \frac{LW}{4} - 39$ <b>B</b> $L = \frac{LW}{2} - 39$	2
 PVC schwarz	325 411-XX-1-20 02 - 2500mm 03 - 3200mm	Seitendichtung side seal	$L = LH - 10$	1
	325 409-XX-1-20 01 - 5100mm roh / mill finish 02 - 5100mm E6 / CO	Vertikalprofil vertical profile	$L = LH - 10$	2
 PVC schwarz	325 412-XX-1-20 01 - 2500mm 02 - 3200mm	Mitteldichtung central seal	$L = LH - 10$	1
	255 069-XX-1-20 01 - 6250mm roh / mill finish 02 - 6250mm E6 / CO	Justierbügelprofil adjustable bracket profile	<b>A</b> $L = \frac{LW}{4} + 37$ <b>B</b> $L = \frac{LW}{2} + 37$	1
	325 424-01-1-20	Gummidichtung rubber seal	GB GH	2
	325 137-02-1-20	Gummidichtung rubber seal	GB GH	2
	050 121-12-3-32	Bürste brush	<b>A</b> $L = \frac{LW}{4} + 24$ <b>B</b> $L = \frac{LW}{2} + 24$	1
	325 082-21-1-20	Gleiterprofil slide profile	<b>A</b> $L = \frac{LW}{4} + 24$ <b>B</b> $L = \frac{LW}{2} + 24$	1
		Glasscheibe glass pane	<b>A</b> $GB = \frac{LW}{4} - 11$ $GH = LH - 76$ <b>B</b> $GB = \frac{LW}{2} - 11$ $GH = LH - 76$	1

pro Fahrflügel Schnellläufer  
per moving leaf fast

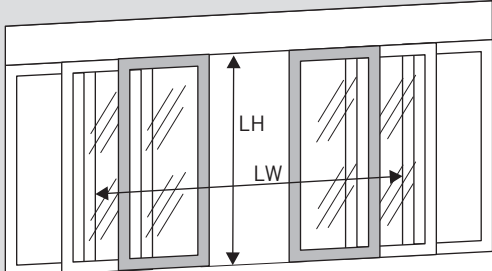
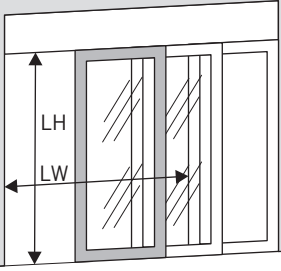
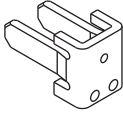
TST-FLEX ES 200  
 Fahrflügel Schnellläufer  
 Moving leaf fast

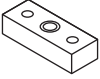
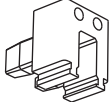
A		B		St. pc.
Profile/Zubehör Profils/accessories	Artikelnummer Article-number	Bezeichnung Name	Zuschnittsformel Cutting Formula	
pro Fahrflügel Schnellläufer per moving leaf fast				
				
				
	Montageset – Fahrflügel fixing set – moving leaf 4400320	FLEX-Eckverbinder corner join		2
		Halteklammer retaining clip		2
		Gegenhalteplatte retaining plate		2
		Verdrehsicherung anti twist protection		2

TST-FLEX ES 200  
 Fahrflügel Schnellläufer  
 Moving leaf fast

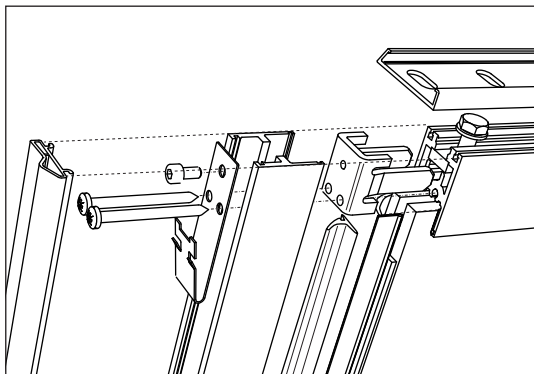

**Gebogene Scheiben richtungsgleich einsetzen!**

Rechts wie gezeichnet

Links spiegelbildlich

**Curved glass must be assembled in matching form!**

Right-hand version as per drawing

Left-hand version mirror image

$$FH = LH - 10$$

$$FB = LW/4 + 29$$

$$C = (LW-800) / 4$$

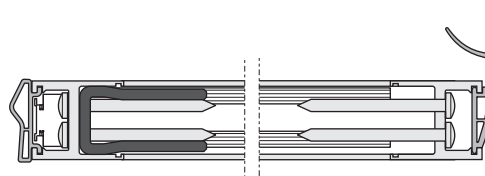
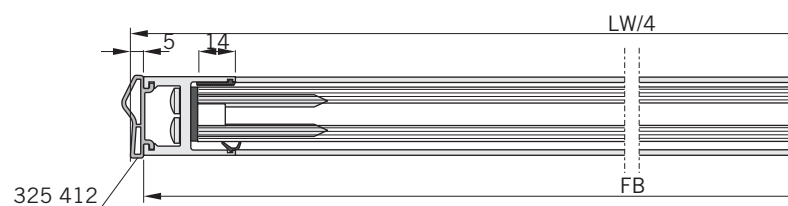
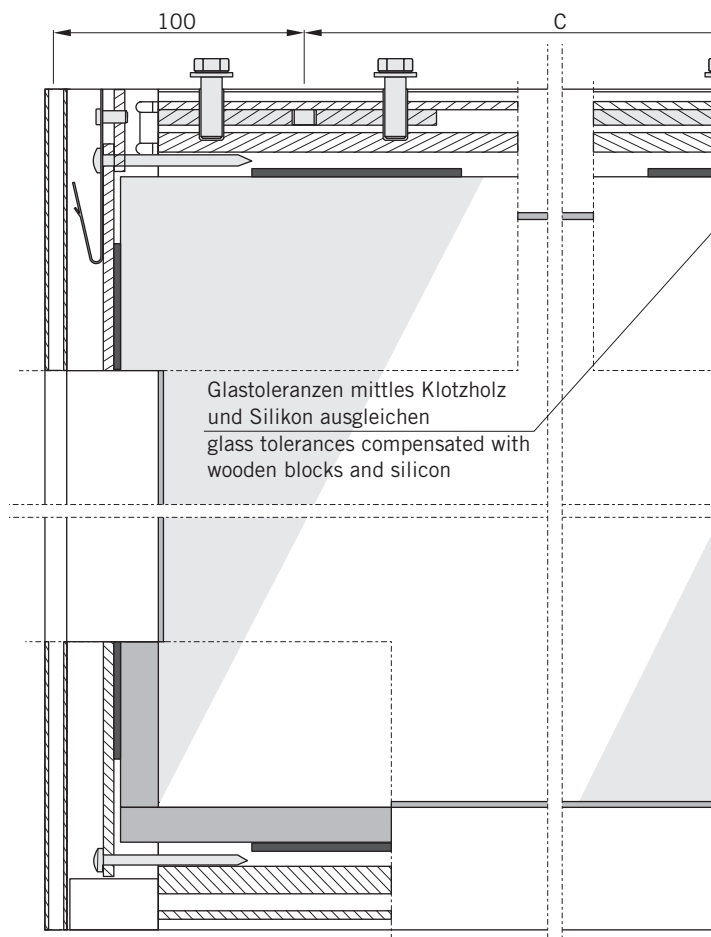
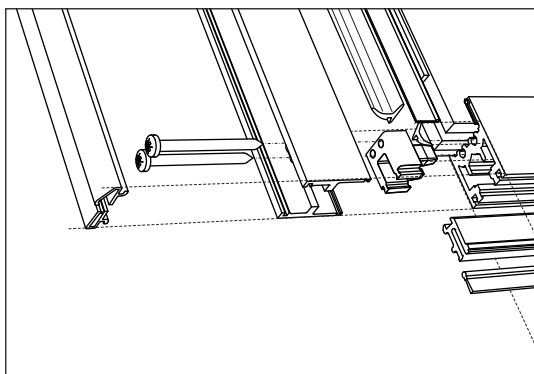

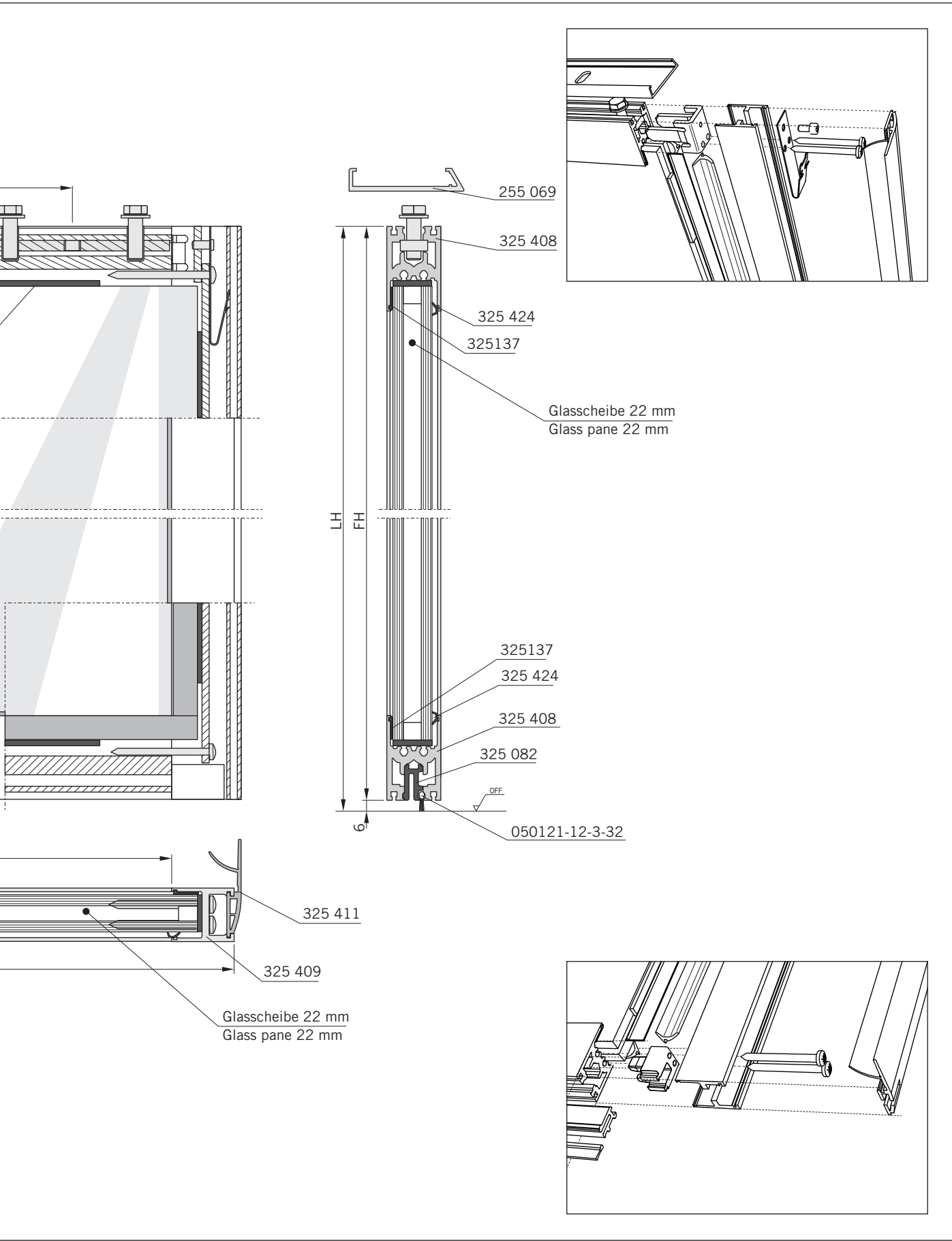



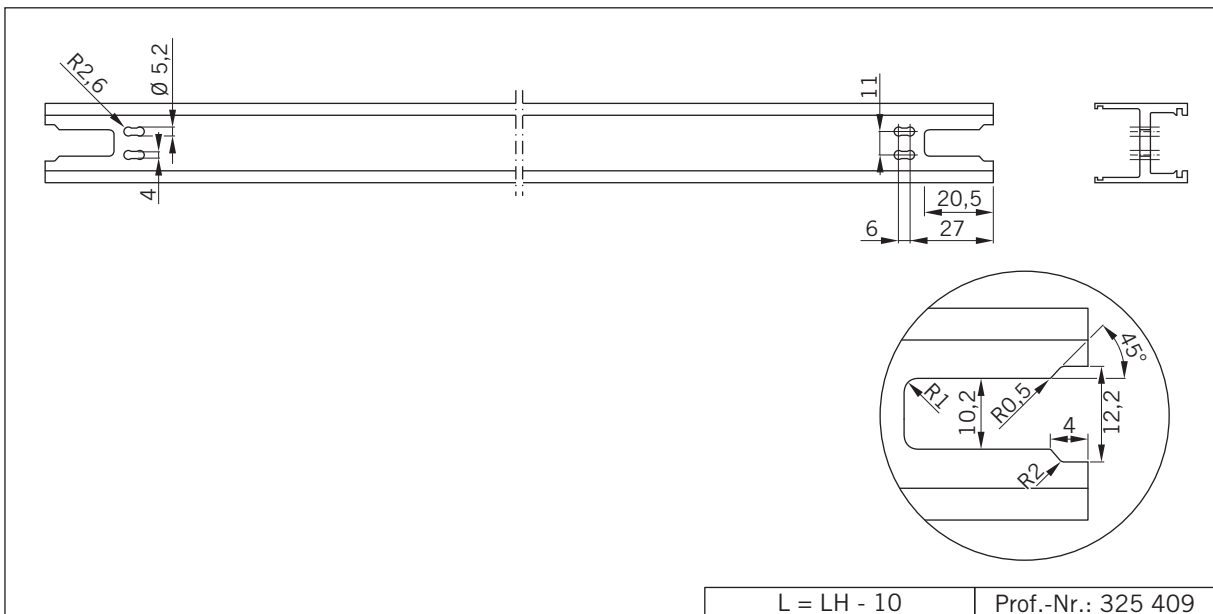
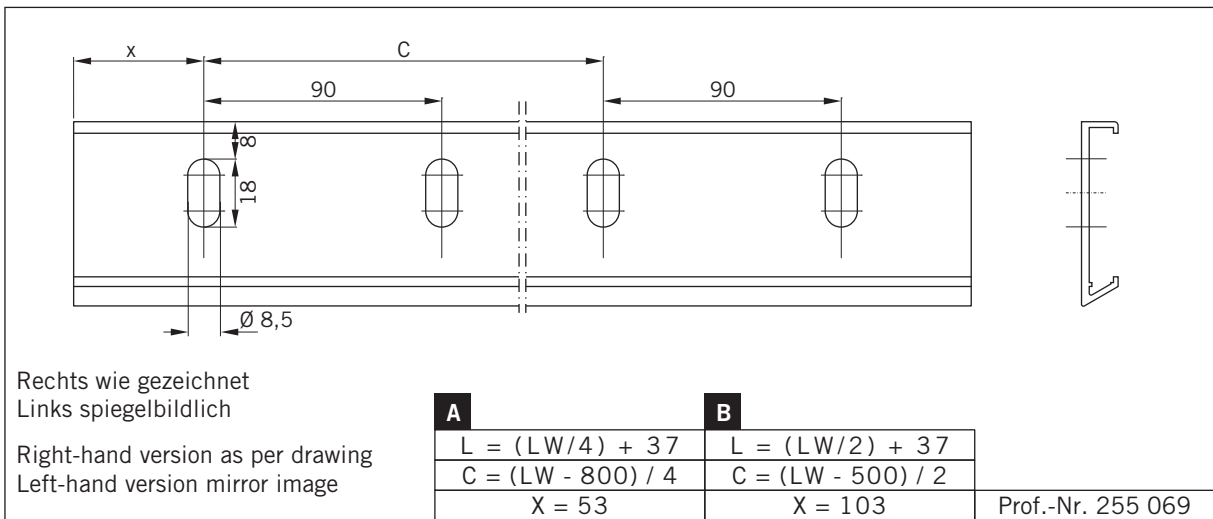
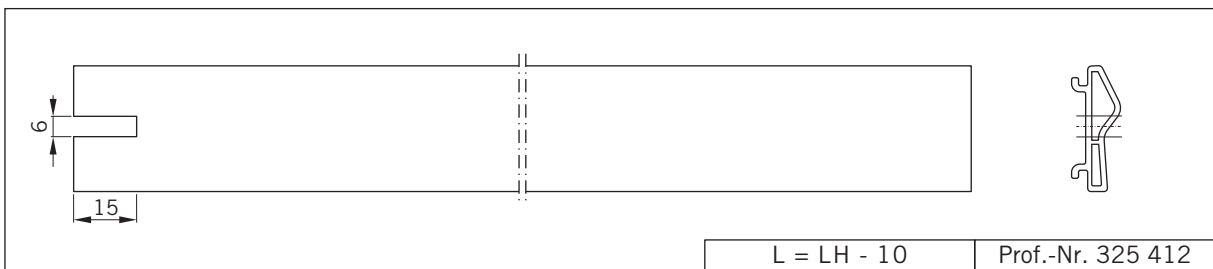
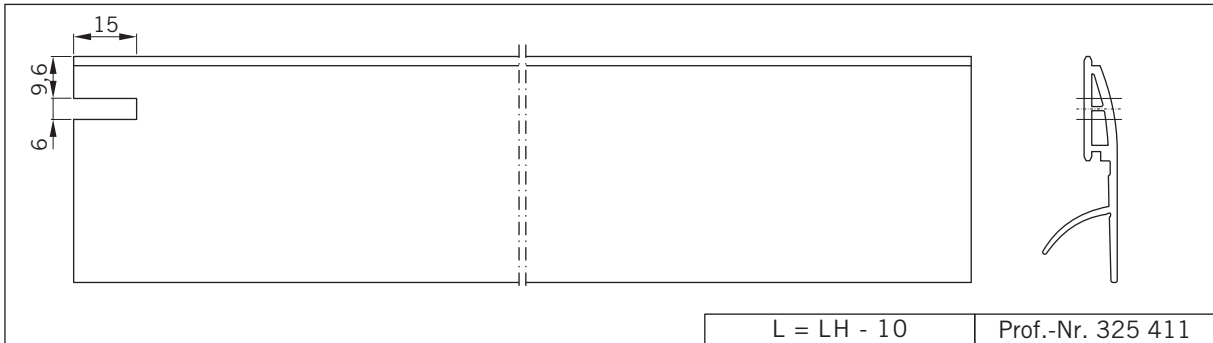



TST-FLEX ES 200  
 Fahrflügel Schnellläufer  
 Moving leaf fast

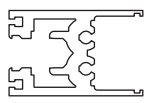

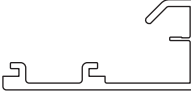

TST-FLEX ES 200  
 Fahrflügel Langsamläufer  
 Moving leaf slow

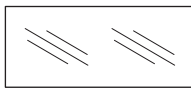
A		B		St. pc.
Profile/Zubehör Profils/accessories	Artikelnummer Article-number	Bezeichnung Name	Zuschnittsformel Cutting Formula	
	325 408-XX-1-20 01 - 6250mm roh / mill finish 02 - 6250mm E6 / CO 06 - 4250mm roh / mill finish 07 - 4250mm E6 / CO	Horizontalprofil horizontal profile	<b>A</b> $L = \frac{LW}{4} - 39$ <b>B</b> $L = \frac{LW}{2} - 39$	2
 PVC schwarz	325 411-XX-1-20 02 - 2500mm 03 - 3200mm	Seitendichtung side seal	$L = LH - 6$	1
	325 409-XX-1-20 01 - 5100mm roh / mill finish 02 - 5100mm E6 / CO	Vertikalprofil vertical profile	$L = LH - 6$	2
	325 418-XX-1-20 01 - 5100 mm roh / mill finish 02 - 5100 mm E6 / CO	Seitendichtung side seal profile	$L = LH - 6$	1
	255 069-XX-1-20 01 - 6250mm roh / mill finish 02 - 6250mm E6 / CO	Justierbügelprofil adjustable bracket profile	<b>A</b> $L = \frac{LW}{4} + 39$ <b>B</b> $L = \frac{LW}{2} + 39$	1
	325 424-01-1-20	Gummidichtung rubber seal	GB GH	2
	325 137-02-1-20	Gummidichtung rubber seal	GB GH	2
	050 107-12-3-32	Bürste brush	<b>A</b> $L = \frac{LW}{4} + 27$ <b>B</b> $L = \frac{LW}{2} + 27$	1
		Glasscheibe glass pane	<b>A</b> $GB = \frac{LW}{4} - 11$ $GH = LH - 72$ <b>B</b> $GB = \frac{LW}{2} - 11$ $GH = LH - 72$	1

pro Fahrflügel Langsamläufer  
per moving leaf slow

TST-FLEX ES 200  
 Fahrflügel Langsamläufer  
 Moving leaf slow

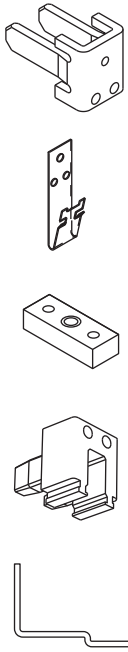
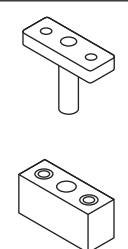
A		B		St. pc.
Profile/Zubehör Profils/accessories	Artikelnummer Article-number	Bezeichnung Name	Zuschnittsformel Cutting Formula	
pro Fahrflügel Langsamläufer per moving leaf slow				
	Montageset – Fahrflügel fixing set – moving leaf 4400320	FLEX-Eckverbinder corner join		2
		Halteklammer retaining clip		3
		Gegenhalteplatte retaining plate		2
		Verdrehsicherung anti twist protection		2
		Führungswinkel U-Form guide bracket U-shape		1
	Montageset – Bodenführung fixing set – floor rail 4400340	Führungsbolzen guide pin		2
		Gleitstück slide block		2



TST-FLEX ES 200  
 Fahrflügel Langsamläufer  
 Moving leaf slow

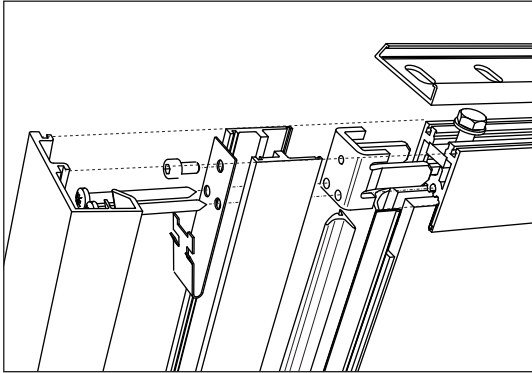

**Gebogene Scheiben richtungsgleich einsetzen!**  
 Rechts wie gezeichnet  
 Links spiegelbildlich  
**Curved glass must be assembled in matching form!**  
 Right-hand version as per drawing  
 Left-hand version mirror image

FH = LH - 6  
 FB = LW/4 + 35  
 C = (LW-800) / 4

257034 gekürzt auf ca. 55 mm  
 257034 abridged to approx. 55 mm

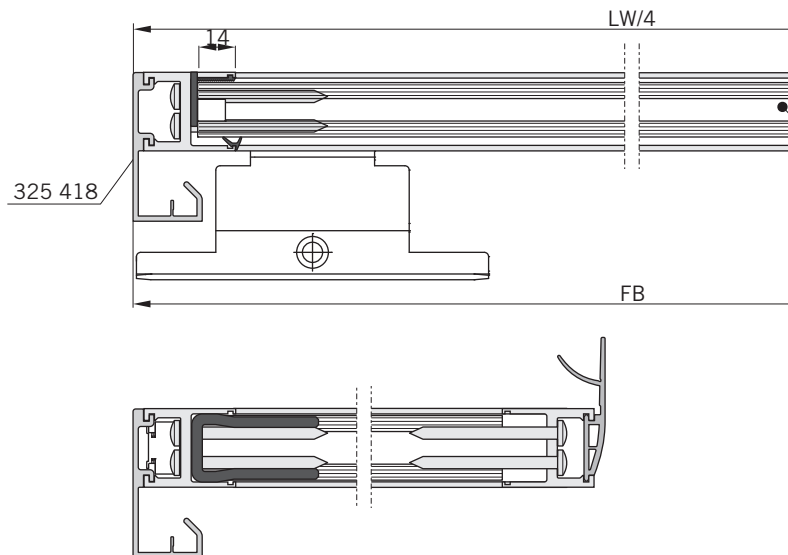
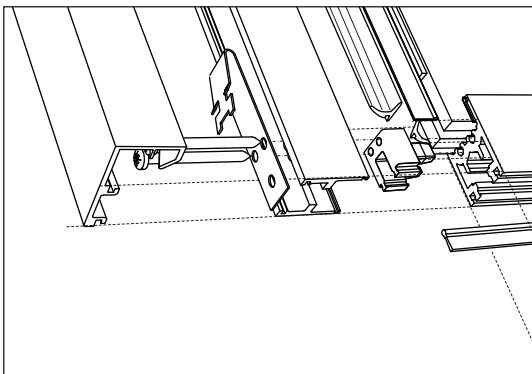
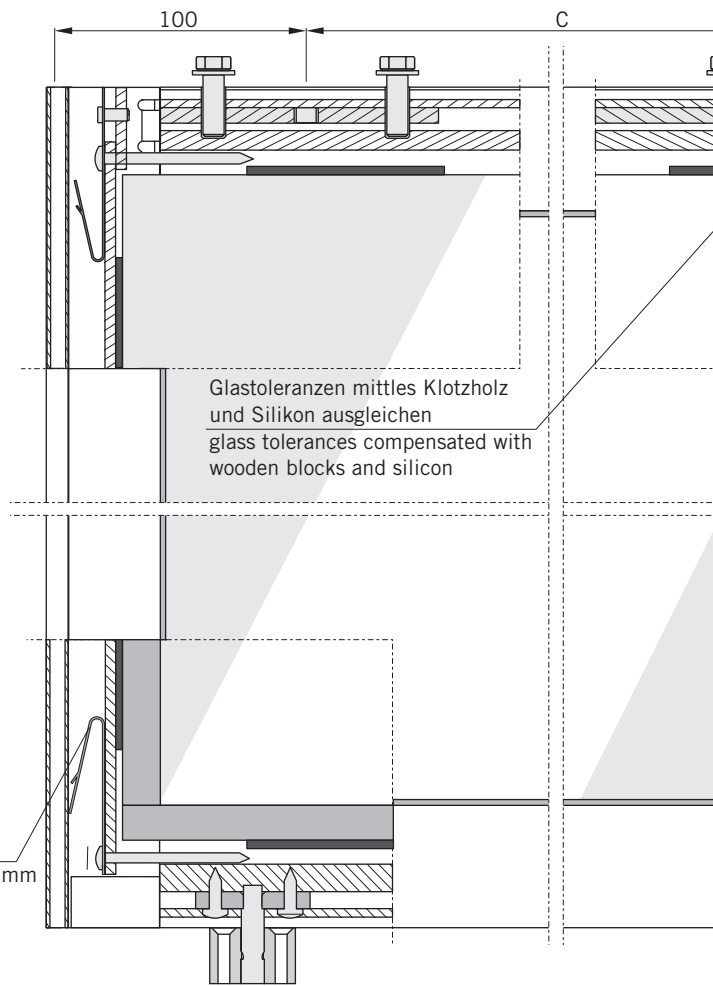

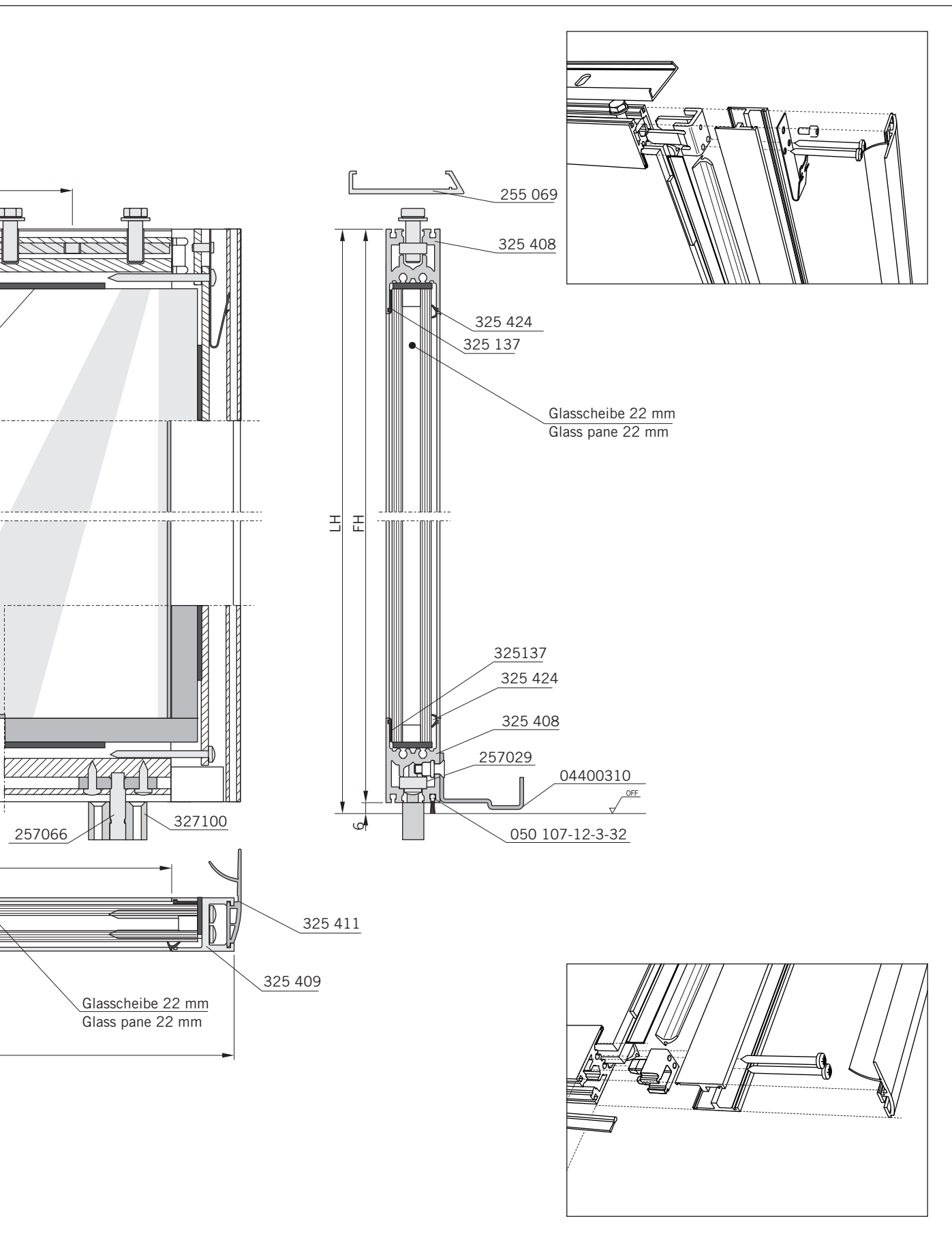

TST-FLEX ES 200  
 Fahrflügel Langsamläufer  
 Moving leaf slow

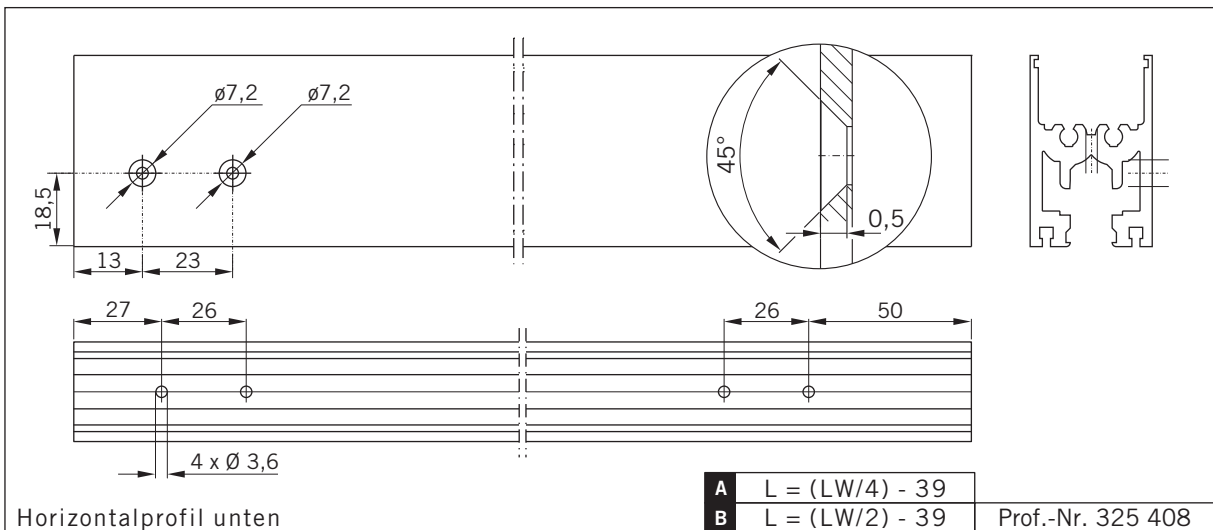
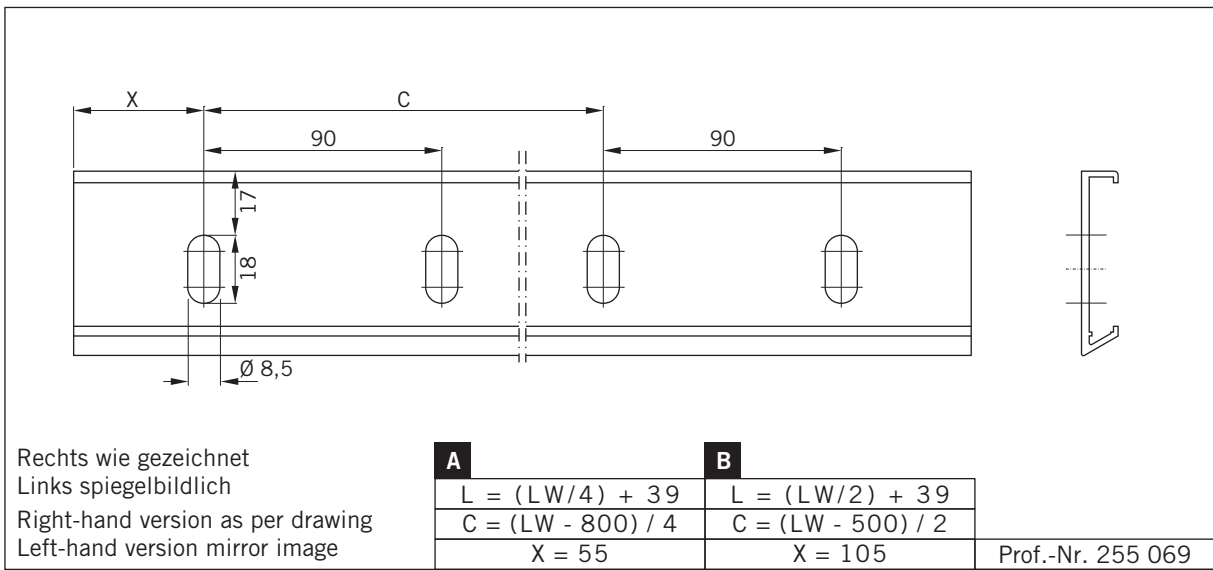
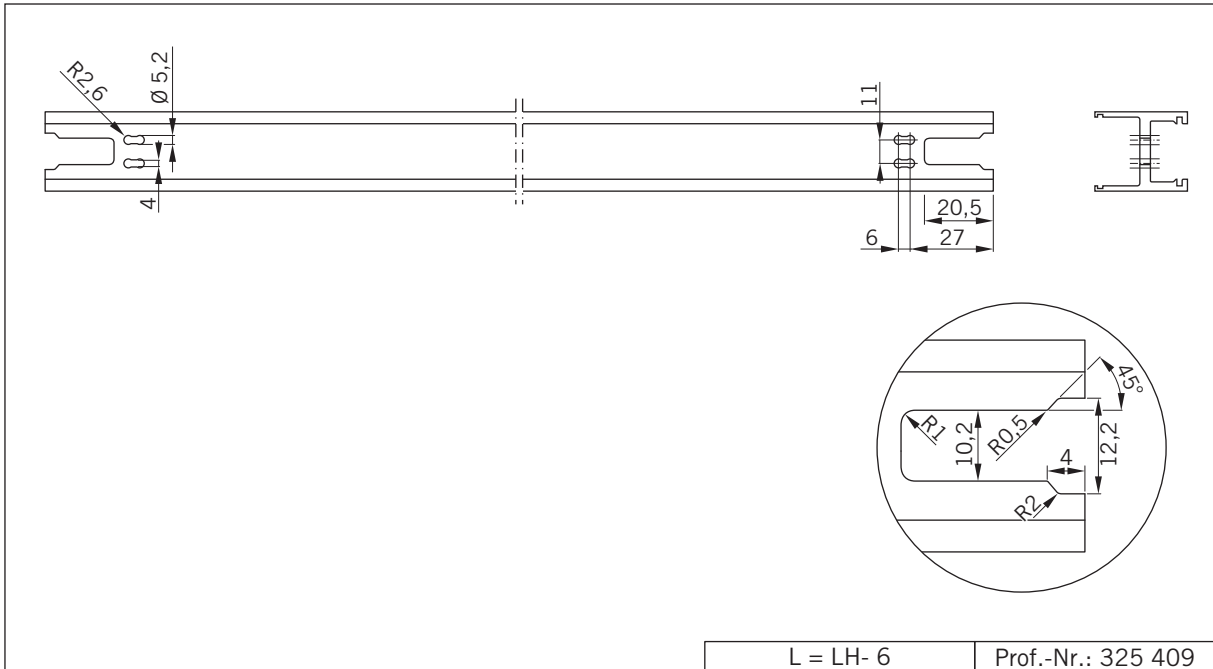

TST-FLEX ES 200

Seitenteil





side panel

A		B		St. pc.
Profil/Zubehör Profils/accessories	Artikelnummer Article-number	Bezeichnung Name	Zuschnittsformel Cutting Formula	pro Seitenteil per side panel
	325 408-XX-1-20 01 - 6250mm roh / mill finish 02 - 6250mm E6 / CO 06 - 4250mm roh / mill finish 07 - 4250mm E6 / CO	Horizontalprofil horizontal profile	<b>A</b> $L = \frac{(B-LW)}{2} - 89$	2
			<b>B</b> $L = (B-LW) - 89$	
	325 409-XX-1-20 01 - 5100 mm roh / mill finish 02 - 5100 mm E6 / CO	Vertikalprofil vertical profile	$L = LH - 2,5$	2
	325 219-XX-1-20 01 - 5100mm roh / mill finish 02 - 5100mm E6 / CO	U-Profil U-profile	$L = LH - 2,5$	1
	255 088-00-1-20	Ausnehmung nur bei LM-Träger 100mm Only LM-girder 100mm cut out	$L = LH + 97,5$	
	325 418-XX-1-20 01 - 5100 mm roh / mill finish 02 - 5100 mm E6 / CO	Seitendichtung side seal profile	$L = LH - 2,5$	1
	325 413-XX-1-20 01 - 6250mm roh / mill finish 02 - 6250mm E6 / CO 06 - 4250mm roh / mill finish 07 - 4250mm E6 / CO	Bodenschiene ground rail track	<b>A</b> $L = \frac{(B-LW)}{2} - 89$	1
			<b>B</b> $L = (B-LW) - 89$	
	325 424-01-1-20	Gummidichtung rubber seal	GB GH	2
	325 137-02-1-20	Gummidichtung rubber seal	GB GH	2
		Glasscheibe glass pane	<b>A</b> $GB = \frac{B-LW}{2} - 61$ $GH = LH - 70$	1
			<b>B</b> $GB = (B-LW) - 61$ $GH = LH - 70$	

TST-FLEX ES 200

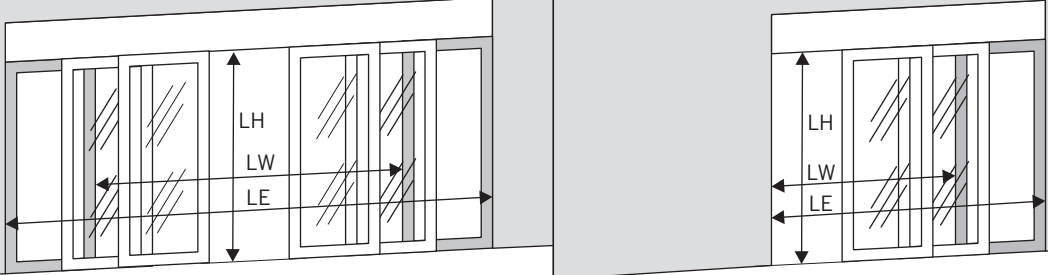
Seitenteil

side panel

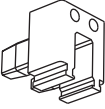
<div style="display: flex; justify-content: space-between;"> <span><b>A</b></span> <span><b>B</b></span> </div> <div style="text-align: center; margin-top: 10px;"> <math>B = LE - 10</math> </div> 				pro Seitenteil per side panel
<b>Profile/Zubehör</b> <b>Profils/accessories</b>	<b>Artikelnummer</b> <b>Article-number</b>	<b>Bezeichnung</b> <b>Name</b>	<b>Zuschnittsformel</b> <b>Cutting Formula</b>	<b>St.</b> <b>pc.</b>
   	Montageset – Seitenteil fixing set – side panel 4400330	U-Füllstück U-filler		2
		Halteklammer retaining clip		2
		Gegenhalteplatte retaining plate		2
		Verdrehsicherung anti twist protection		4





# TST-FLEX ES 200

## Seitenteil

### side panel

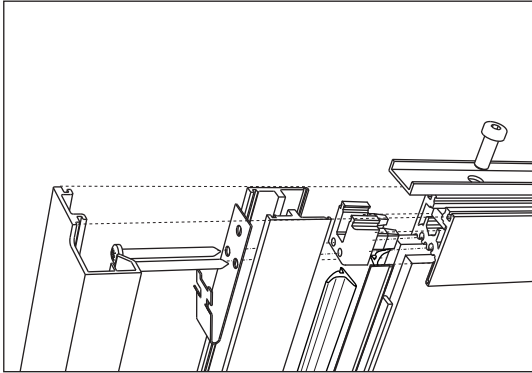

#### **Gebogene Scheiben richtungsgleich einsetzen!**

Rechts wie gezeichnet

Links spiegelbildlich

#### **Curved glass must be assembled in matching form!**

Right-hand version as per drawing

Left-hand version mirror image

$$SH = LH - 2,5$$

$$SB = (B-LW)/2 - 15$$

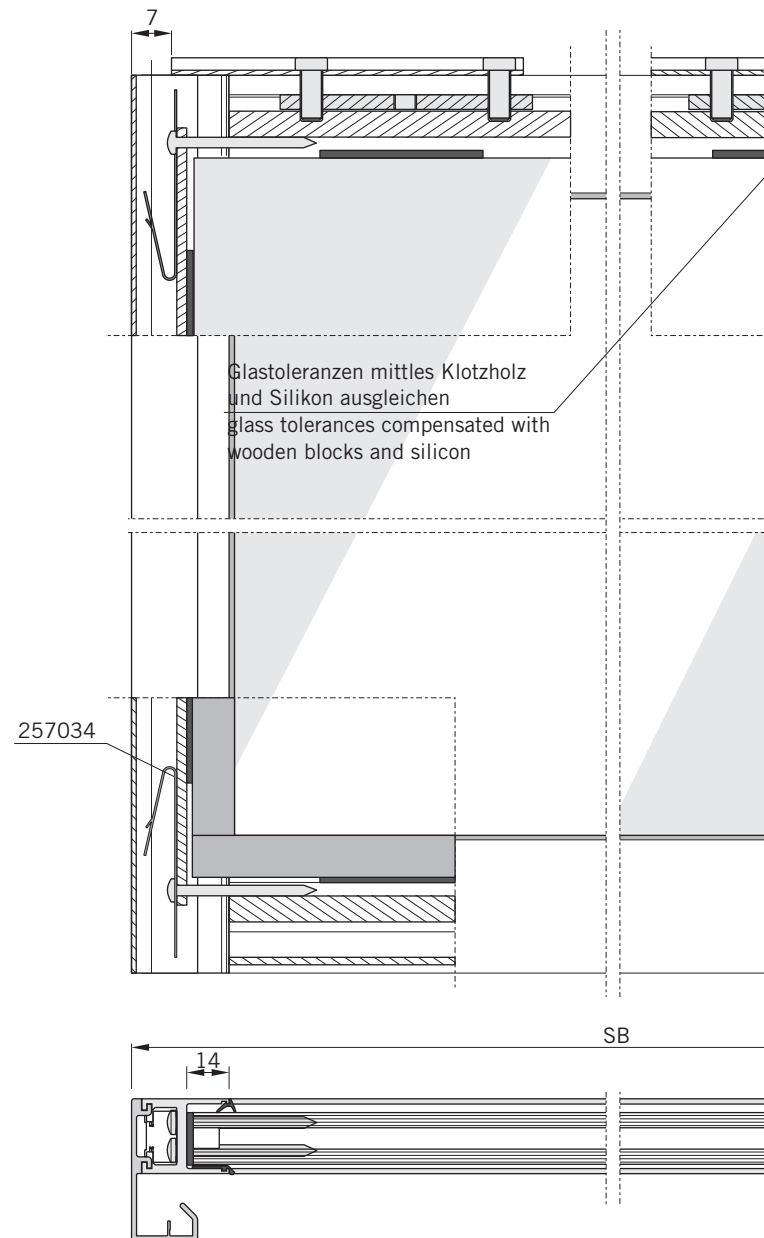
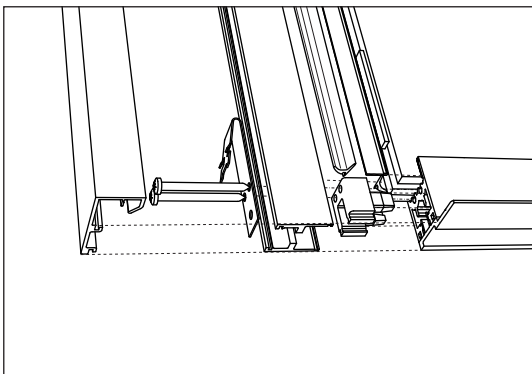

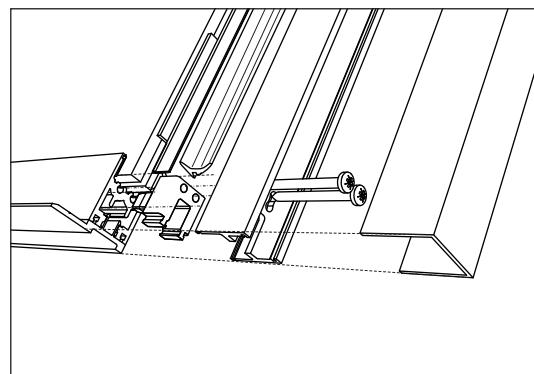
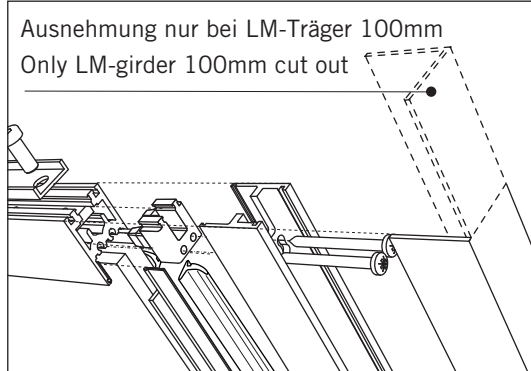
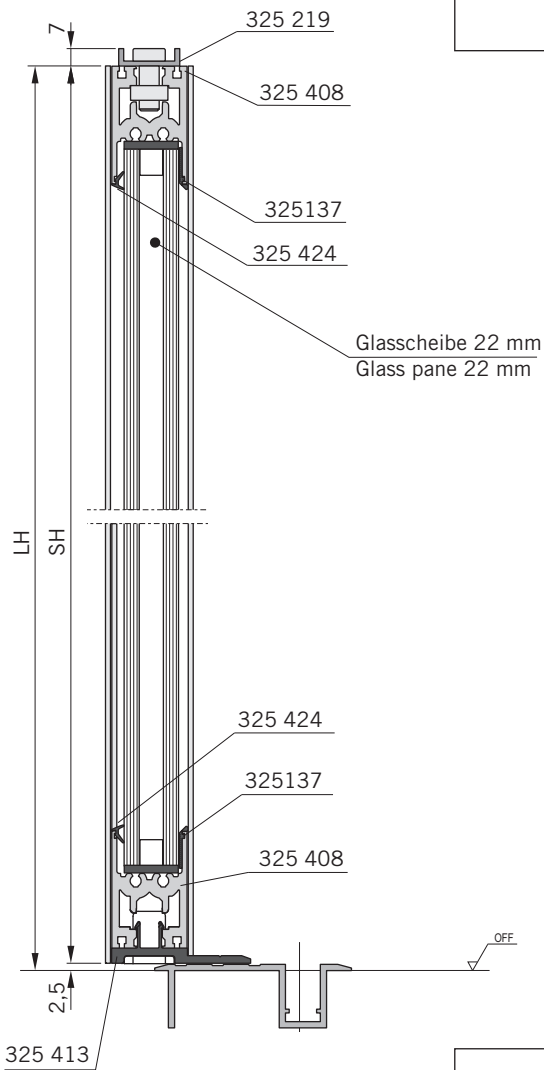
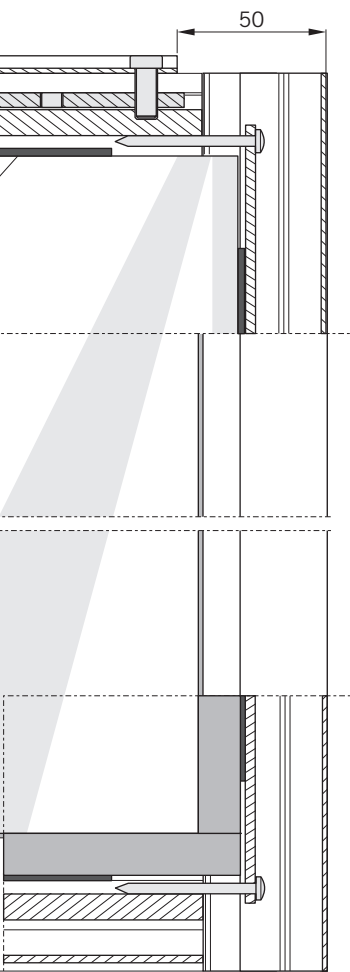

TST-FLEX ES 200

Seitenteil  
side panel

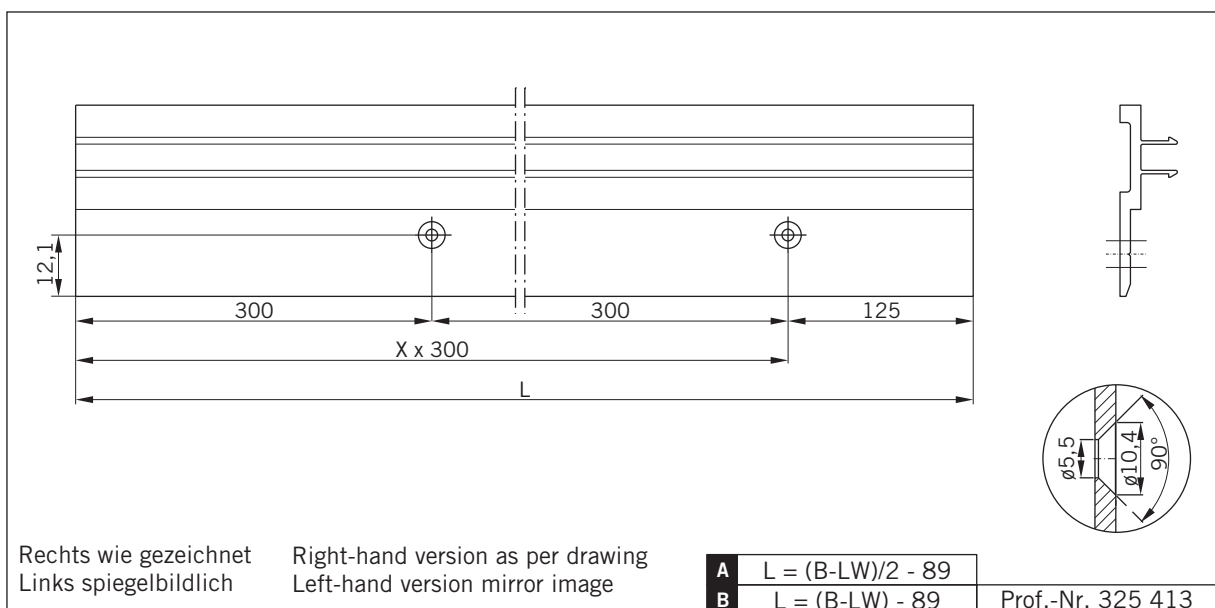
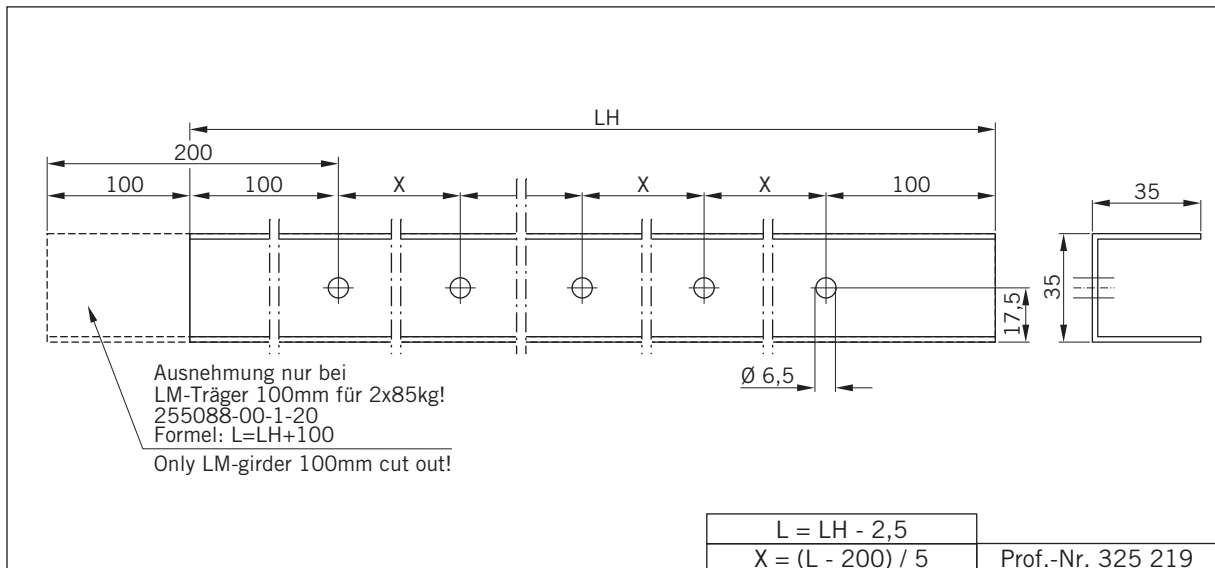
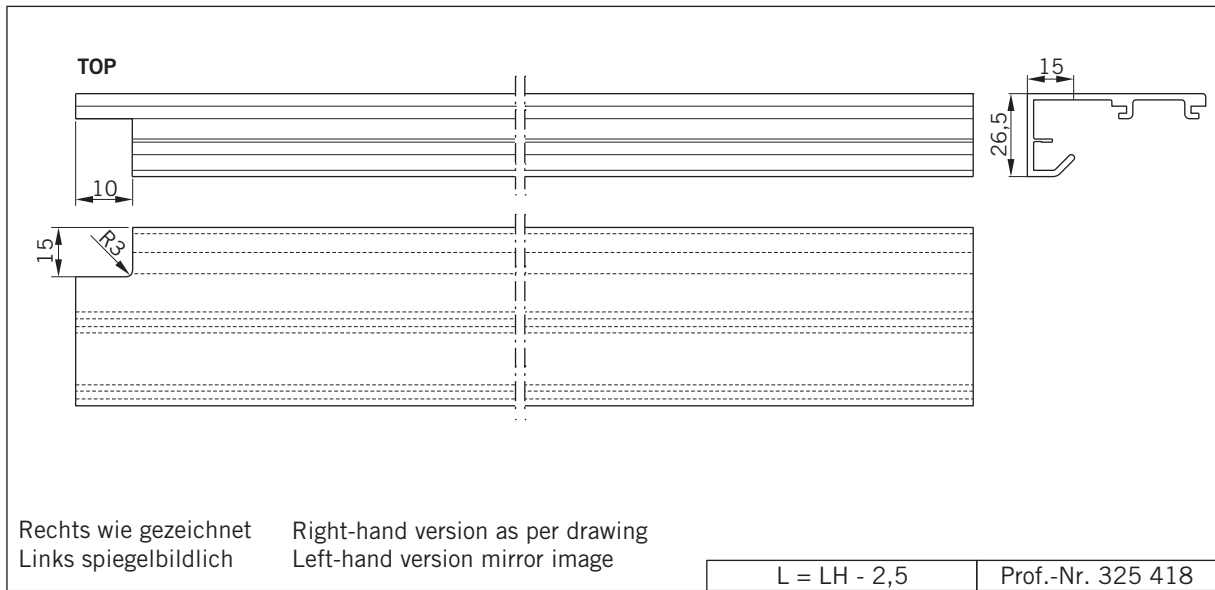

TST-FLEX ES 200

Seitenteil

side panel

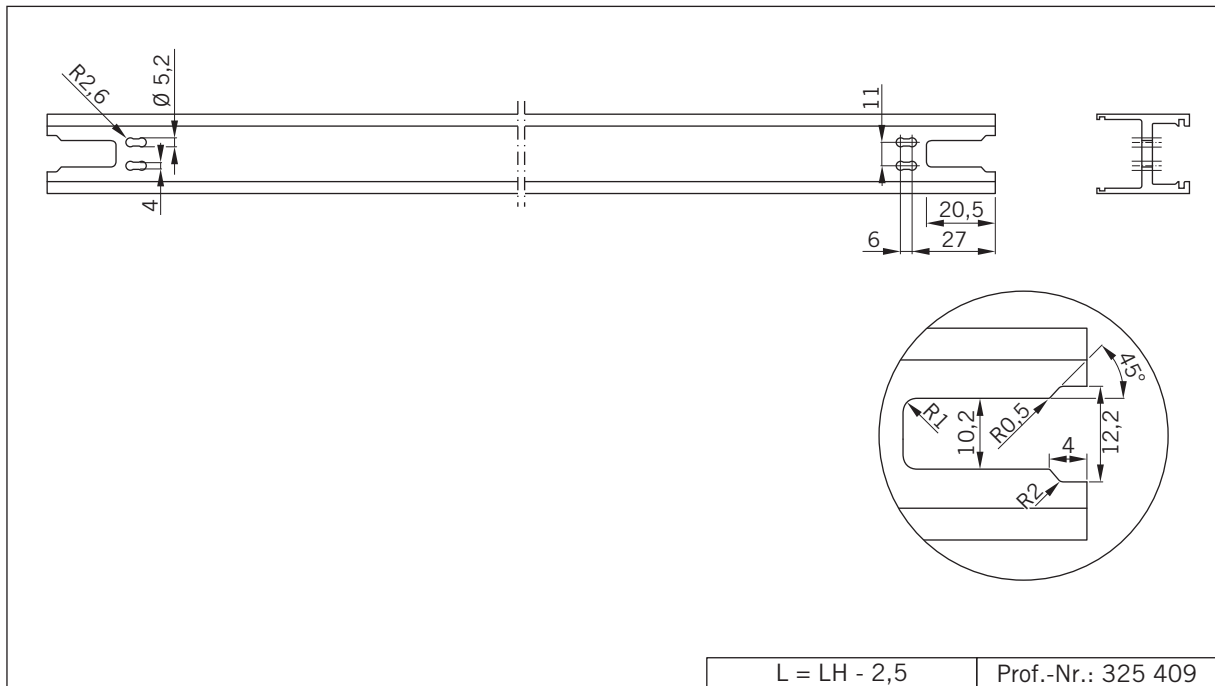

TST-FLEX ES 200  
 ohne Seitenteil  
 without Side panel

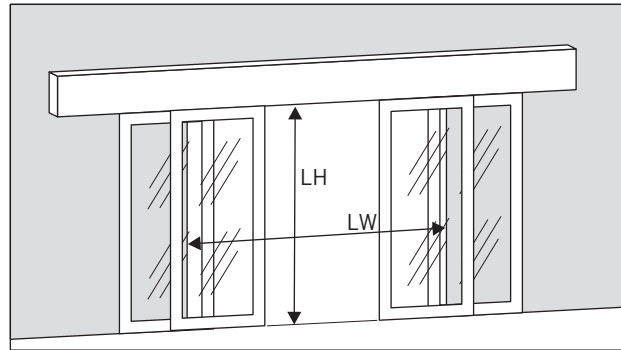

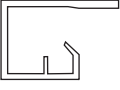
Profile/Zubehör Profils/accessories	Artikelnummer Article-number	Bezeichnung Name	Zuschnittsformel Cutting Formula	St. pc.
	325 420-XX-1-20 01 - 5100mm roh / mill finish 02 - 5100mm E6 / CO	Gegendichtungsprofil Interlock profile	L = LH	2
	004400310	Bodenführungsset Floor guide U-shape		2

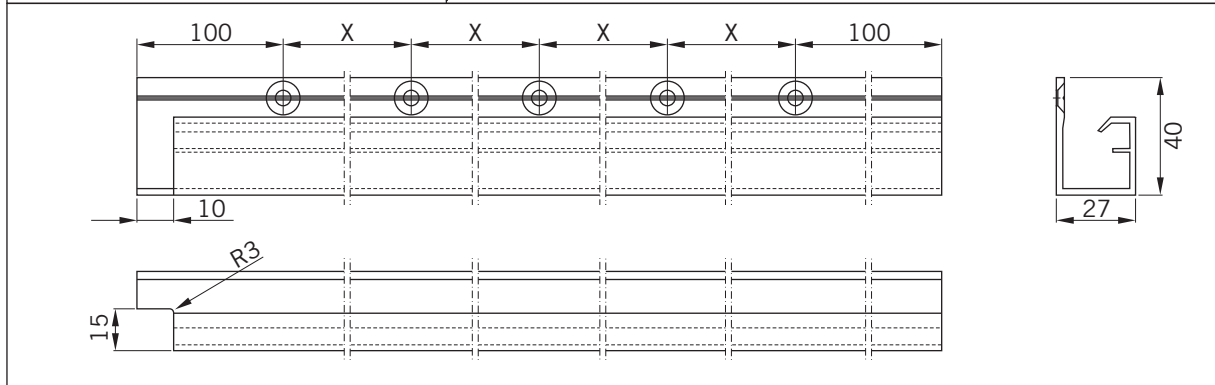
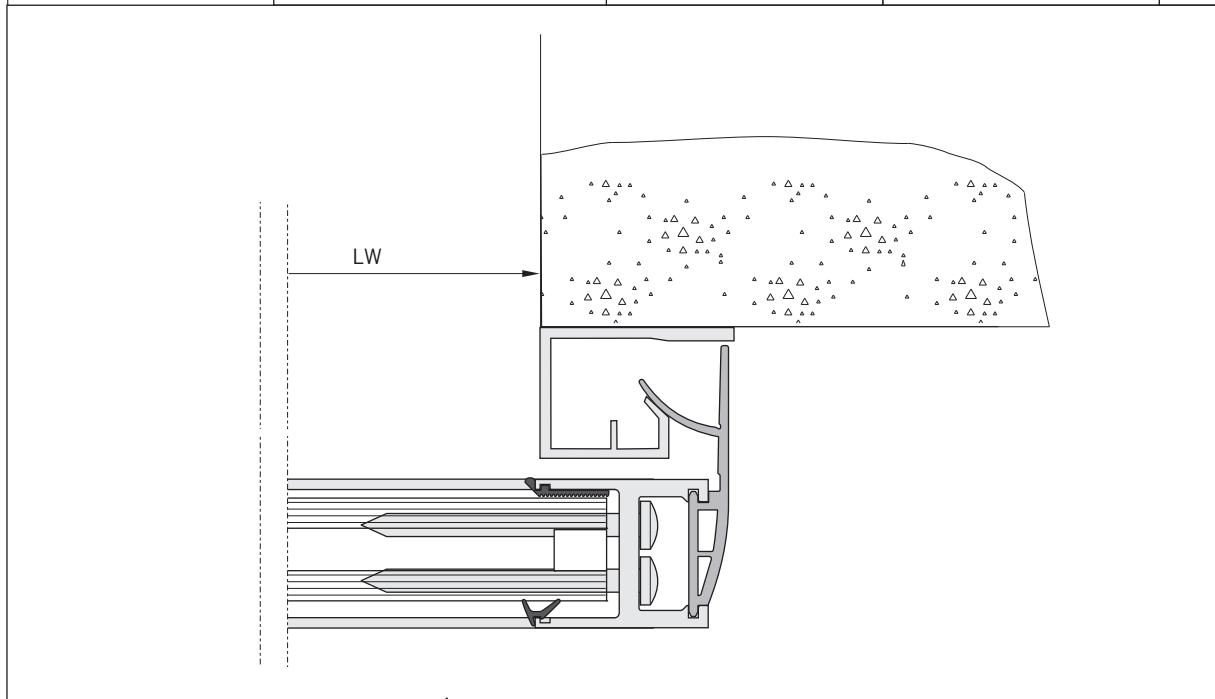





Rechts wie gezeichnet      Right-hand version as per drawing  
 Links spiegelbildlich      Left-hand version mirror image

L = LH

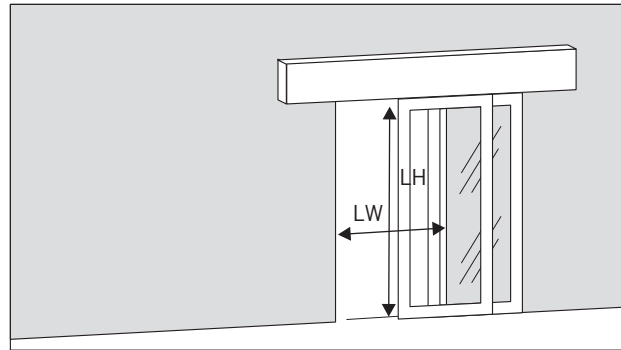
Prof.-Nr. 325 420

TST-FLEX ES 200  
 ohne Seitenteil  
 without Side panel



Profile/Zubehör Profils/accessories	Artikelnummer Article-number	Bezeichnung Name	Zuschnittsformel Cutting Formula	St. pc.
	325 423-XX-1-20 01 - 5100mm roh / mill finsh 02 - 5100mm E6 / CO	Seitenanschlagwinkel side connection bracket	L = LH	1
	325 426-XX-1-20 01 - 5100mm roh / mill finsh 02 - 5100mm E6 / CO	Wandanschlagprofil wall connection profile	L = LH	1
 PVC schwarz	325 412-XX-1-20 01 - 2500mm 02 - 3200mm	Mitteldichtung central seal	L = LH	1

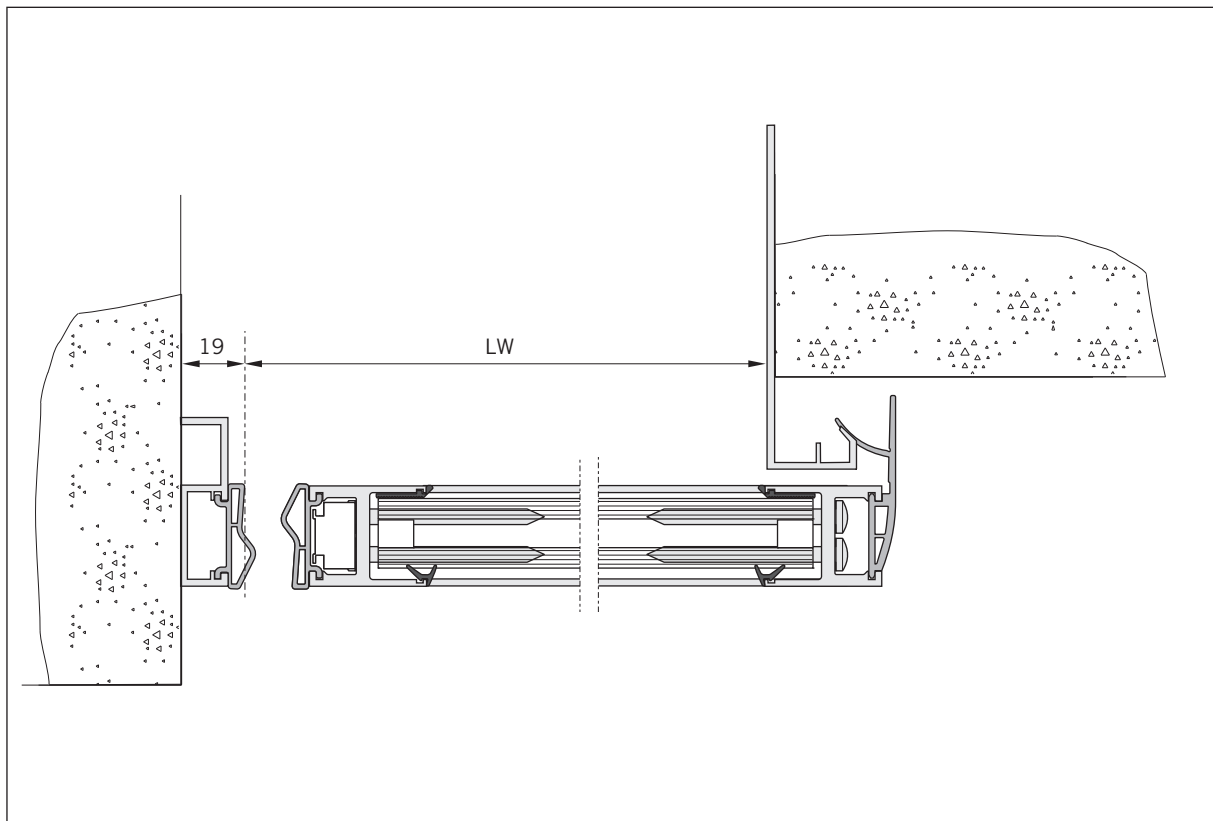

TST-FLEX ES 200  
 ohne Seitenteil  
 without Side panel

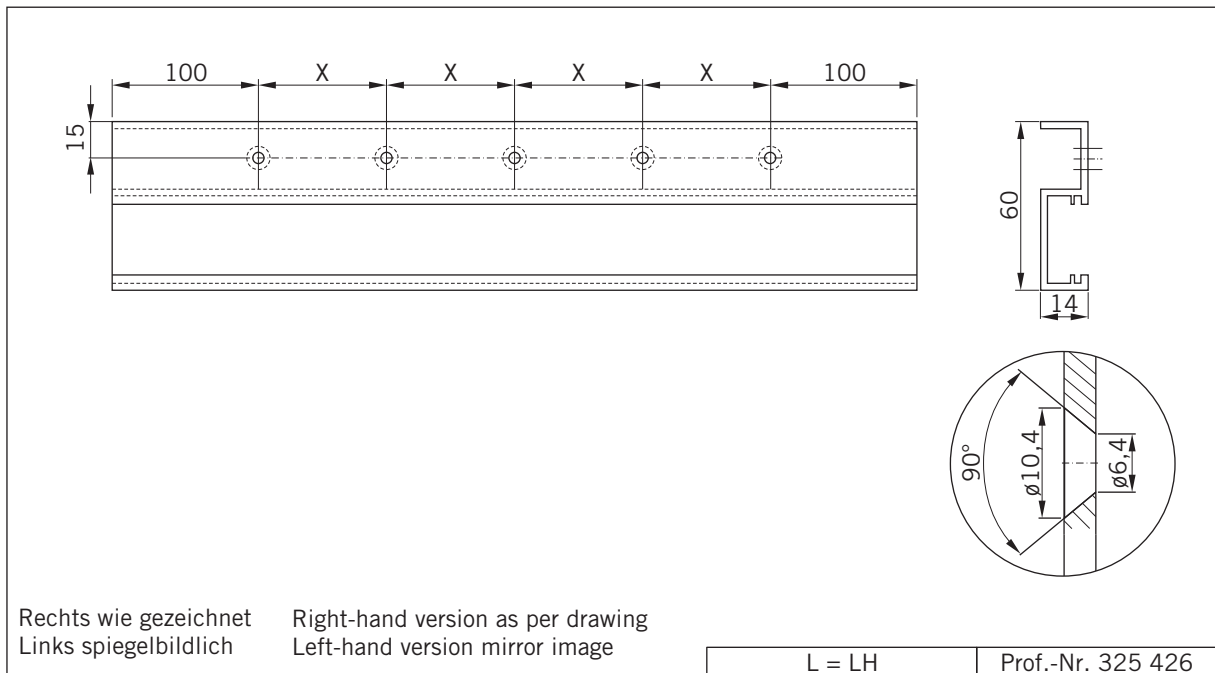
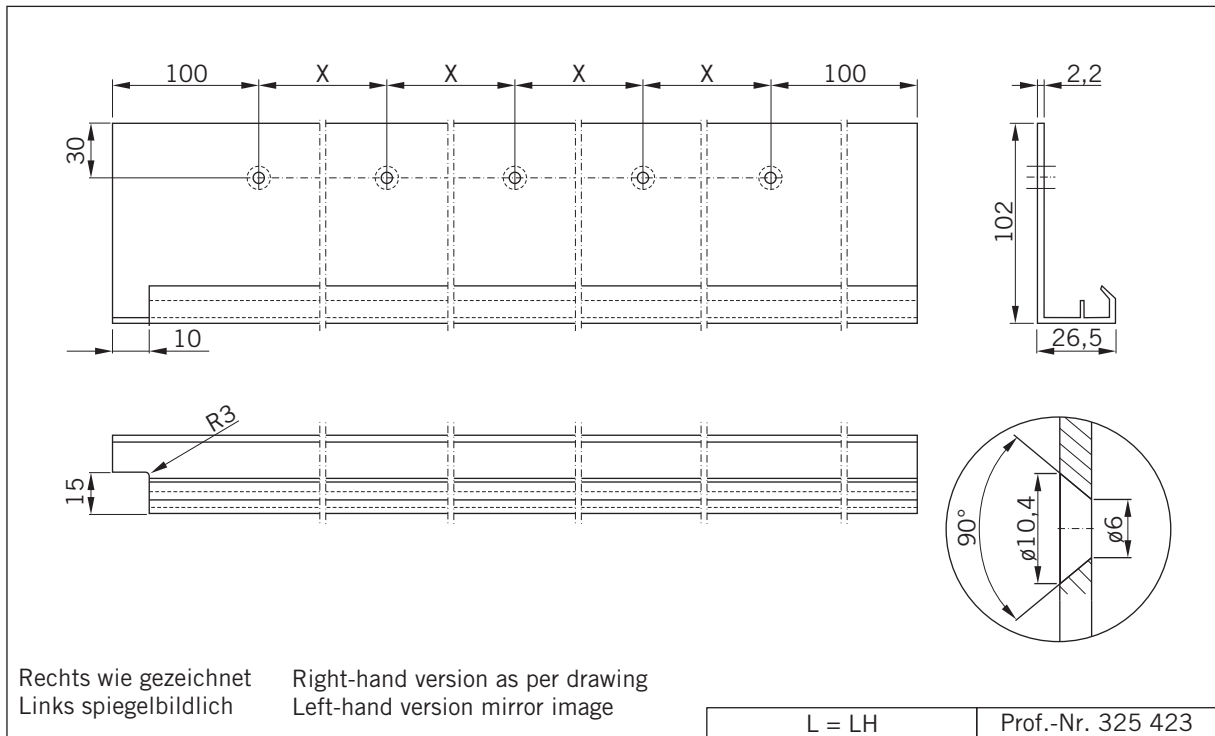





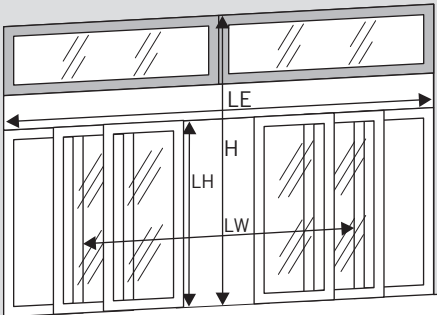
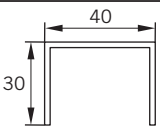
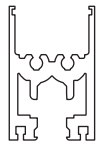
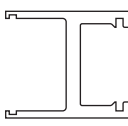
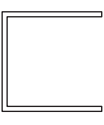

TST-FLEX ES 200

Oberlicht

Transom light

									
Profile/Zubehör Profils/accessories	Artikelnummer Article-number	Bezeichnung Name	Kämpferhöhe Operator height	Zuschnittsformel Cutting Formula	Var. 01 / 1-teilig / 1 part only Var. 02 / 2-teilig / divided 2 parts Var. 03 / 3-teilig / divided 3 parts / Mitte / centre Var. 04 / 3-teilig / divided 3 parts / Außen / external				
	Zeichnungsnr. 257 025-01-1-40 Materialnr. 502091	Deckenabschluß U-Profil top closure U-profile		$L = B + 10$	1	1	1	1	
	325 408-XX-1-20 01 - 6250mm roh / mill finish 02 - 6250mm E6 / CO 06 - 4250mm roh / mill finish 07 - 4250mm E6 / CO	Horizontalprofil horizontal section	Var.01 Var.02 Var.03 Var.04	$L = B - 100$ $L = \frac{(B-30)}{2} -$ $L = LW$ $L = \frac{(B-LW)}{2} -$	2	4	2	4	
	325 409-XX-1-20 01 - 5100mm roh / mill finish 02 - 5100mm E6 / CO	Vertikalprofil vertical section	100 150	$L = H - (LH + 120)$ $L = H - (LH + 170)$	2	4	2	4	
	325 219-XX-1-20 01 - 5100mm roh / mill finish 02 - 5100mm E6 / CO	Seitenabschluß U-Profil side closure U-profile	100 150	$L = H - (LH + 120)$ $L = H - (LH + 170)$	2	2	2	2	
 <p>für Glasscheibe 8mm for glas pane 8mm</p>	325 410-02-1-20	Verglasungsgummi- 8mm rubber seal		GB GH	2	4	2	4	
 <p>für Glasscheibe 22mm for glas pane 22mm</p>	325 424-01-1-20	Gummidichtung rubber seal		GB GH	2	4	2	4	
 <p>für Glasscheibe 8+22mm for glas pane 8+22mm</p>	325 137-02-1-20	Gummidichtung rubber seal		GB GH	2	4	2	4	

TST-FLEX ES 200

Oberlicht

Transom light

Profile/Zubehör Profils/accessories	Artikelnummer Article-number	Bezeichnung Name	Kämpferhöhe Operator height	Zuschnittsformel Cutting Formula	St./pc. <small>Var. 01 / 1-teilig / 1 part only Var. 02 / 2-teilig / divided 2 parts Var. 03 / 3-teilig / divided 3 parts / Mitte / Middle Var. 04 / 3-teilig / divided 3 parts / Außen / Outside</small>
		Glasscheibe 8mm/22mm glass pane	<b>100</b>  Var.01  Var.02  Var.03  Var.04  <b>150</b>  Var.01  Var.02  Var.03  Var.04	$GH = H - (LH + 186)$ $GB = B - 72$ $GH = H - (LH + 186)$ $GB = \frac{(B-30)}{2} - 42$ $GH = H - (LH + 186)$ $GB = LW + 42$ $GH = H - (LH + 186)$ $GB = \frac{(B-LW)}{2} - 92$ $GH = H - (LH + 236)$ $GB = B - 72$ $GH = H - (LH + 236)$ $GB = \frac{(B-30)}{2} - 42$ $GH = H - (LH + 236)$ $GB = LW + 42$ $GH = H - (LH + 236)$ $GB = \frac{(B-LW)}{2} - 92$	1  2  1  2  1  2  2  1  2  1  2
3x	Montageset 4400350	Einlageklotz block insert  Verdrehsicherung anti twist protection			1 2 3 3 Sets

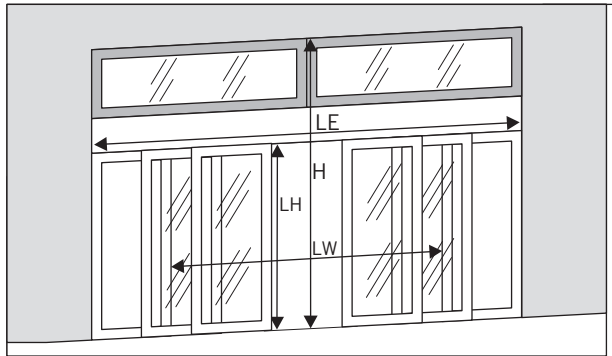

$$B = LE - 10$$





**Gebogene Scheiben richtungsgleich einsetzen!**

Rechts wie gezeichnet

Links spiegelbildlich

**Curved glass must be assembled in matching form!**

Right-hand version as per drawing

Left-hand version mirror image

OB = B - 30	
Antriebshöhe 100mm operator height	$OH = H - (LH+120)$
Antriebshöhe 150mm operator height	$OH = H - (LH+170)$

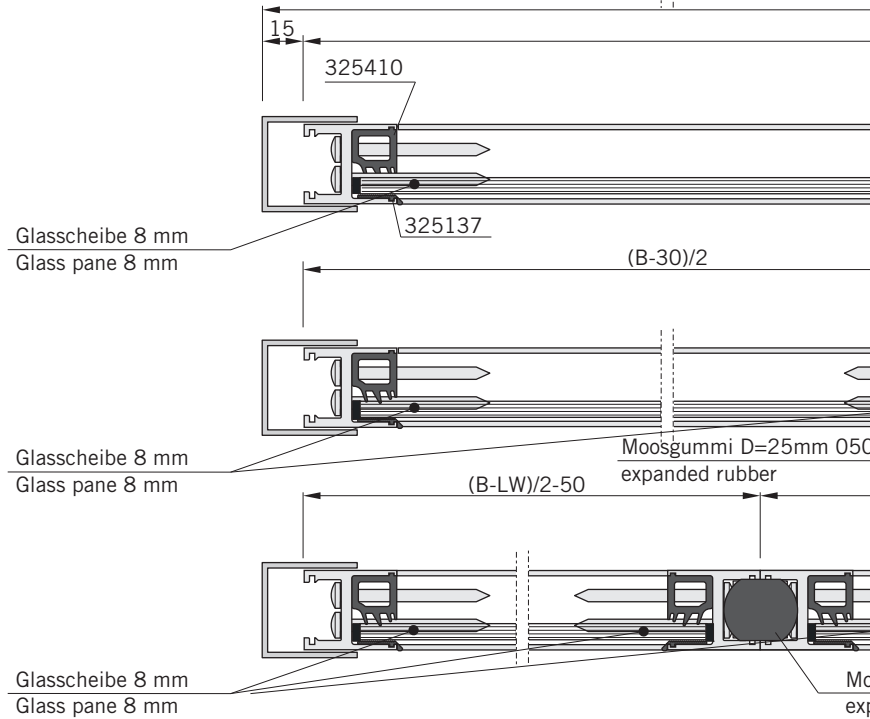
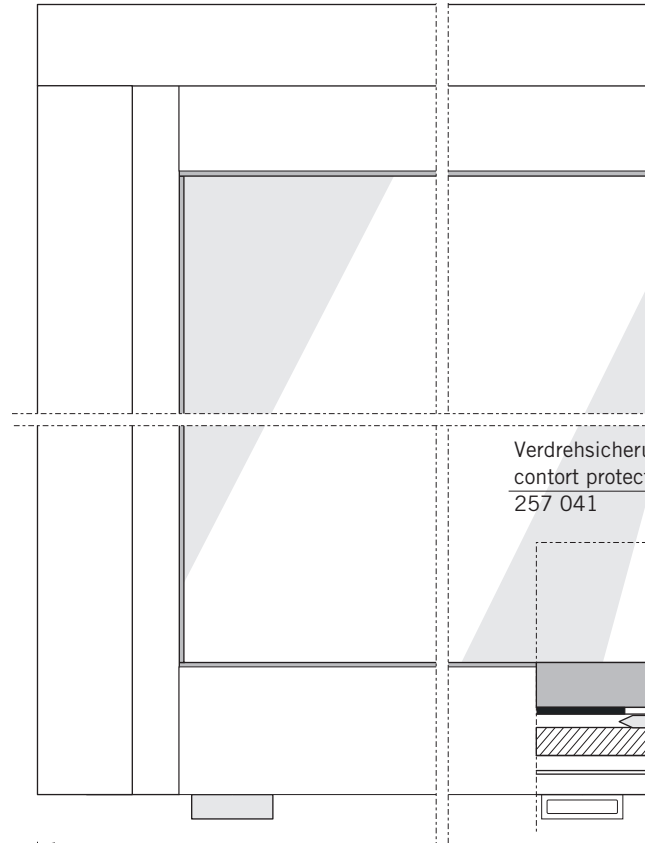

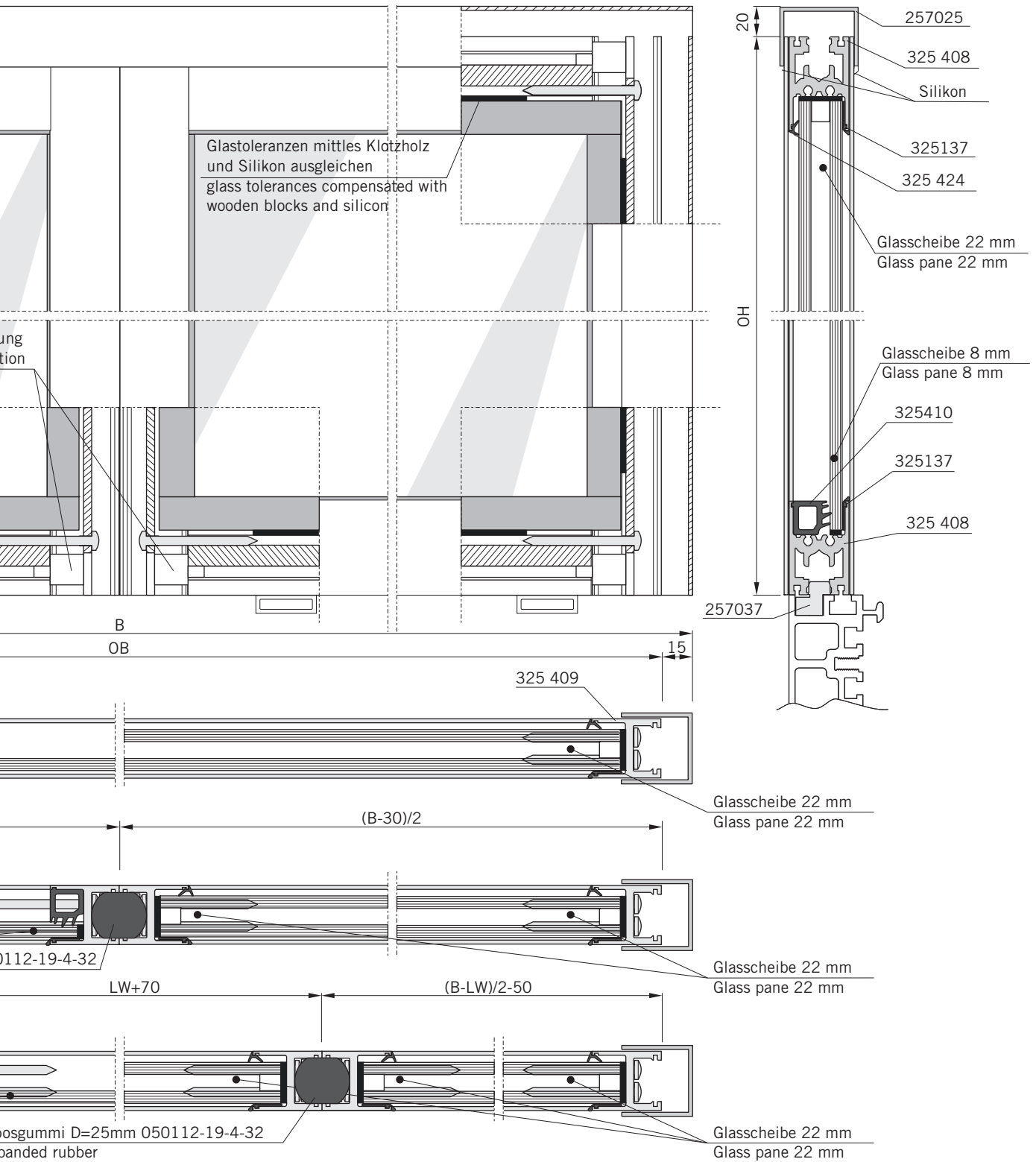

TST-FLEX ES 200

Oberlicht

Transom light

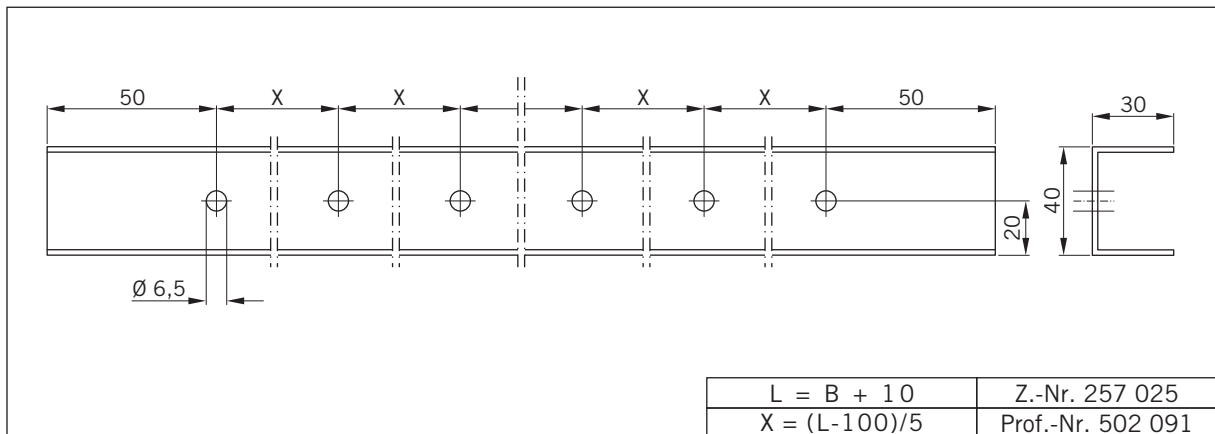
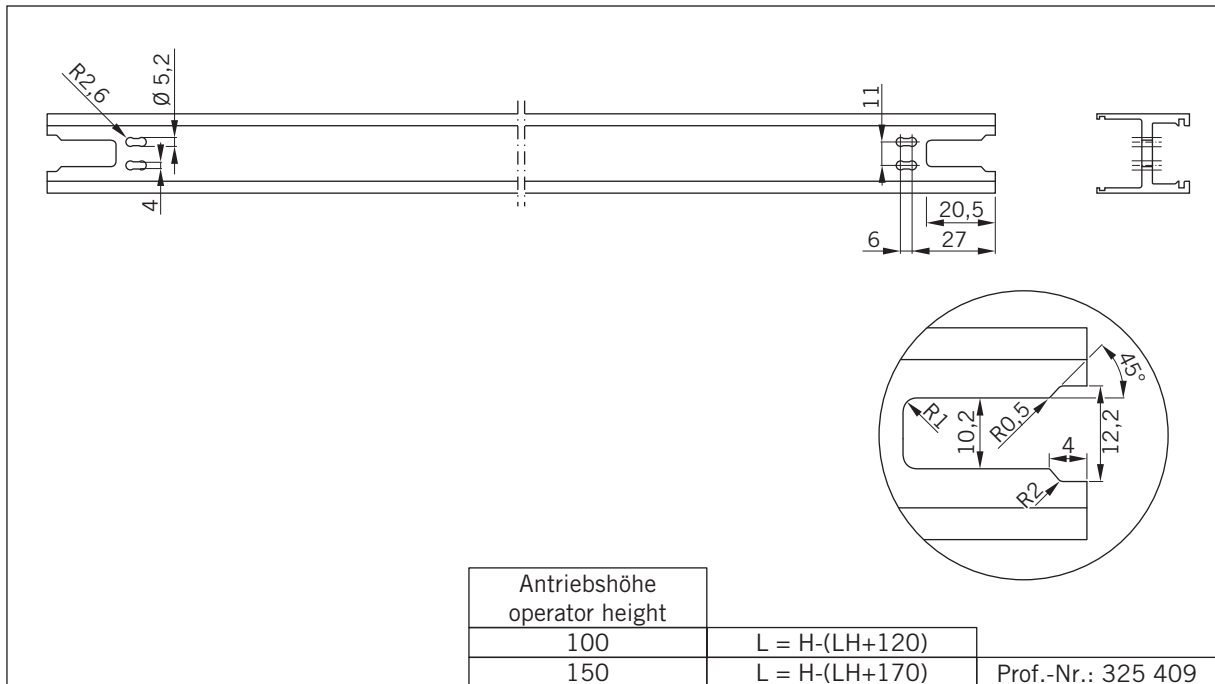

TST-FLEX ES 200  
Bodenführung  
Floor guide

mit Seitenteil  
with side panel

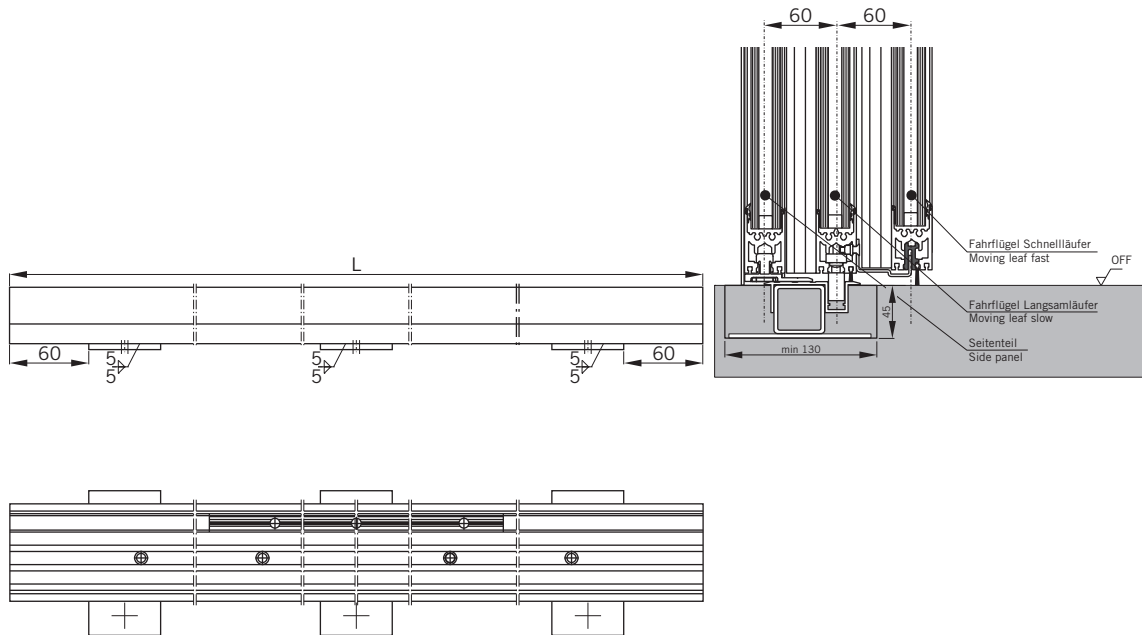

ohne Seitenteil  
without side panel

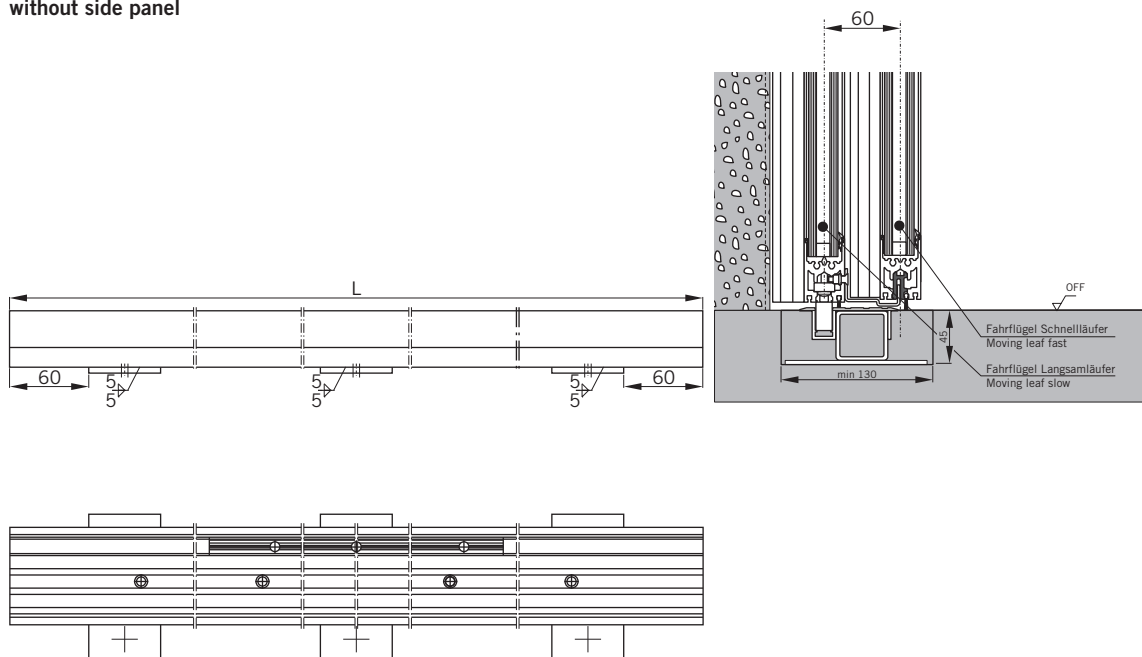

TST-FLEX ES 200

Bodenführung

Floor guide

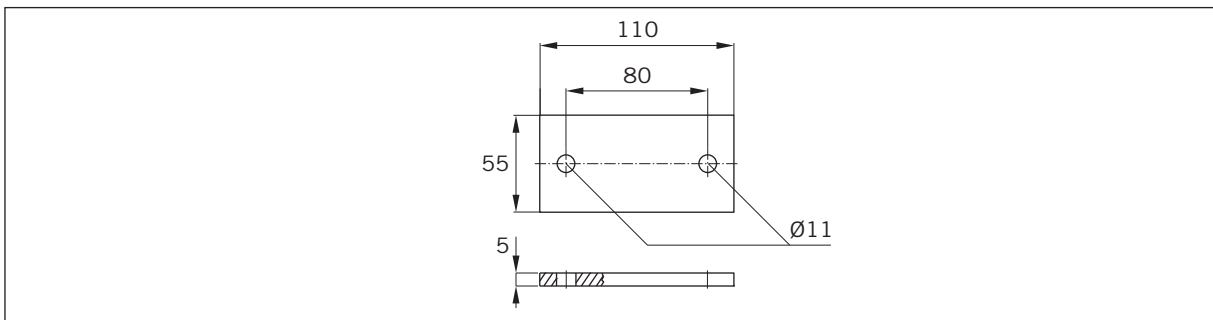
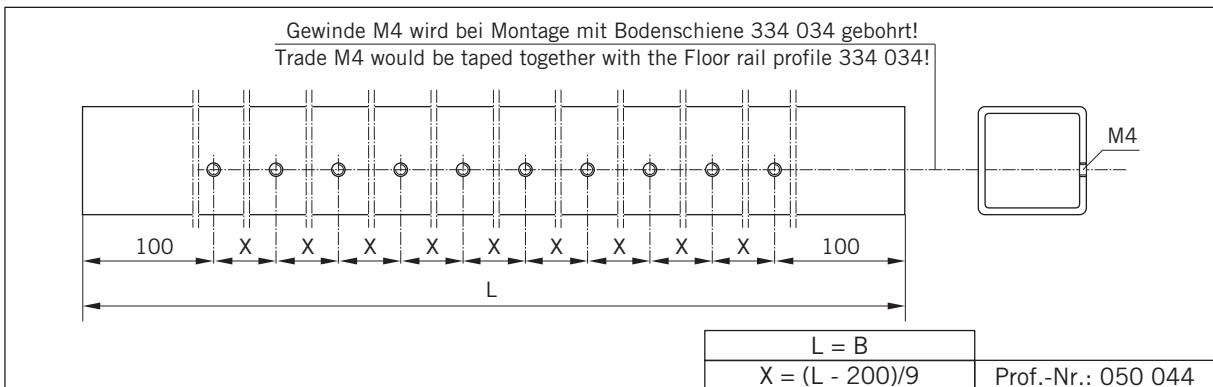
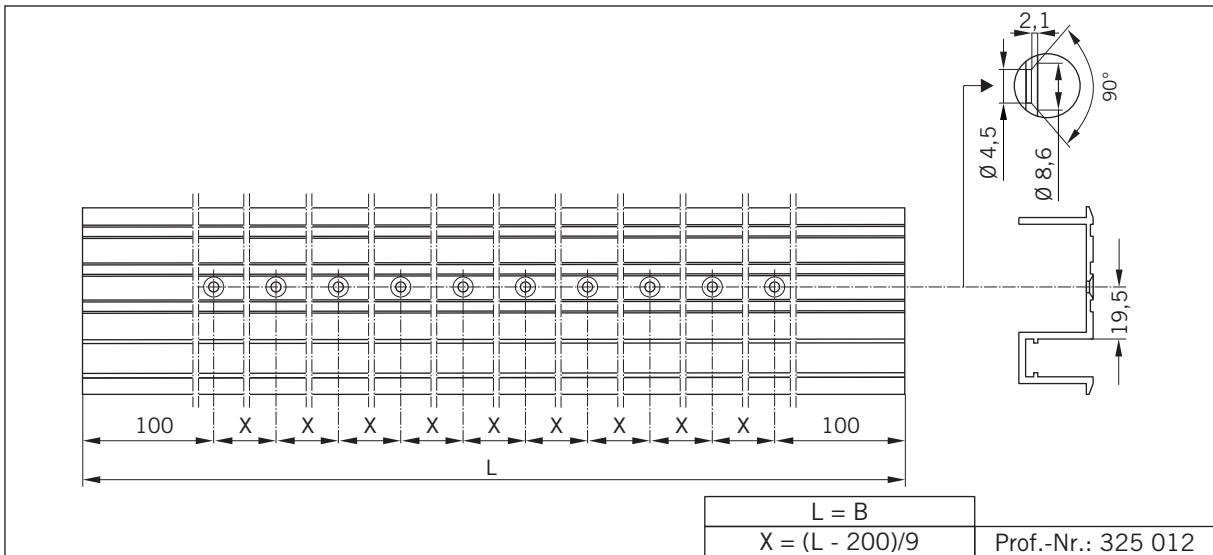
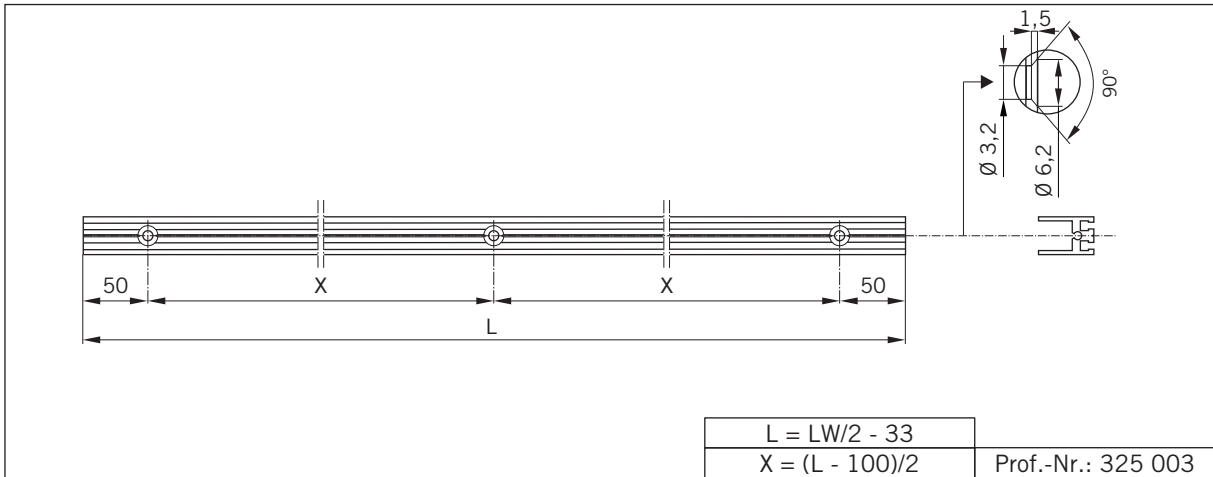

Änderungen vorbehalten  
Subject to change without notice