

9700/F9700 SERIES RIM EXIT DEVICE

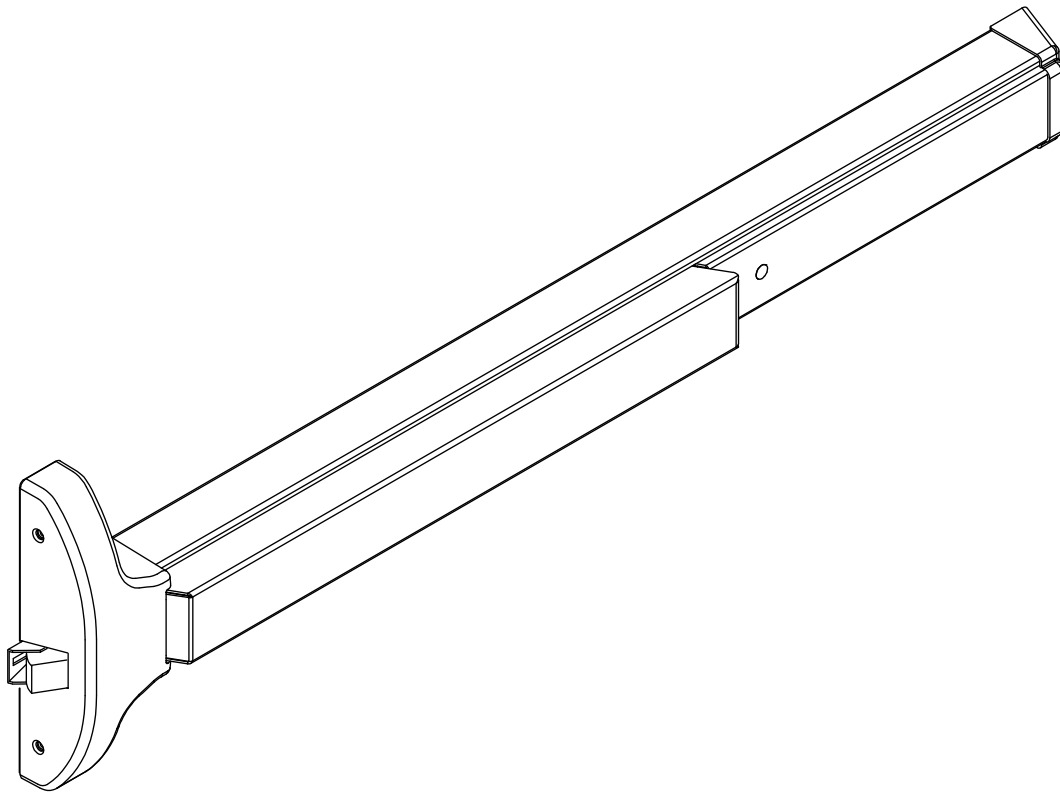

Index:

Screw chart	1
Tools required	2
Outside trim options	3
"03" Additional door prep	4
Device installation	5-8
Options available	9-11
5300 retro-fit preparation	12
Spotting template	13

Note: One set of instructions should be left with building owner after device has been installed.

SCREW CHART

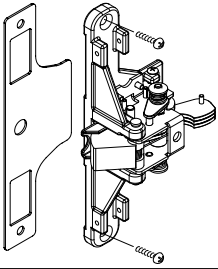

(2) 12-24 x 1" R.H.P.M.S. (Metal or Thru Bolts)

Chassis Mounting

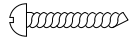

(2) #12 x 1 1/4" R.H.P.T.S. (Wood Door)

Chassis Mounting

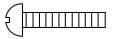

(2) 12-24 x 1" R.H.P.M.S. (Metal or Thru Bolts)

End Cap Bracket

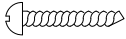

(2) #12 x 1 1/4" R.H.P.T.S. (Wood Door)

End Cap Bracket

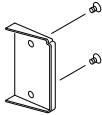
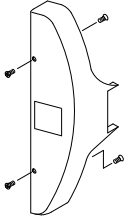

(6) 8-32 x 3/8" F.H.P.M.S.

Chassis Cover & End Cap

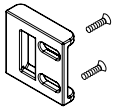

(2) 10-32 x 5/8" F.H.P.M.S. (Metal)

Strike Mounting



(2) #10 x 1" F.H.P.T.S. (Wood Door)

Strike Mounting

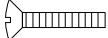
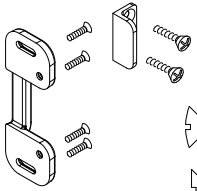

(6) 12-24 x 3/4" O.H.P.M.S. (Metal)

Strike Mounting

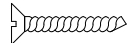

(6) #12 x 1" F.H.P.T.S. (Wood Door)

Strike Mounting

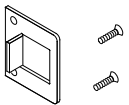

(2) 10-32 x 3/8" F.H.P.M.S. (Metal)

Strike Mounting



(2) #10 x 1" F.H.P.T.S. (Wood Door)

Strike Mounting

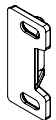

(2) 10-32 x 5/8" F.H.P.M.S. (Metal)

Strike Mounting



(2) #10 x 1" F.H.P.T.S. (Wood Door)

Strike Mounting

HANDING OF DOOR

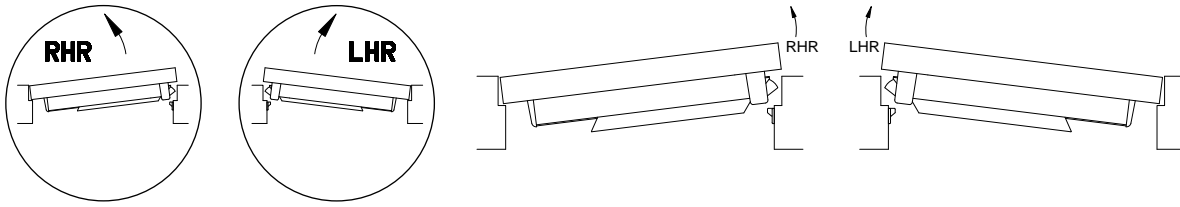

Read the entire instruction sheet prior to installation.

Before Installing Hardware:

1. Door should be fitted and hung.
2. Verify door width, handing and product with carton label for correct exit device & length. (See Step 9)
3. For hand reversal of outside lever trim see page 3.

NOTE:

If device is to be installed over glass lite panels, glass lite shim kit may be required order GK9200.

TYPICAL APPLICATIONS

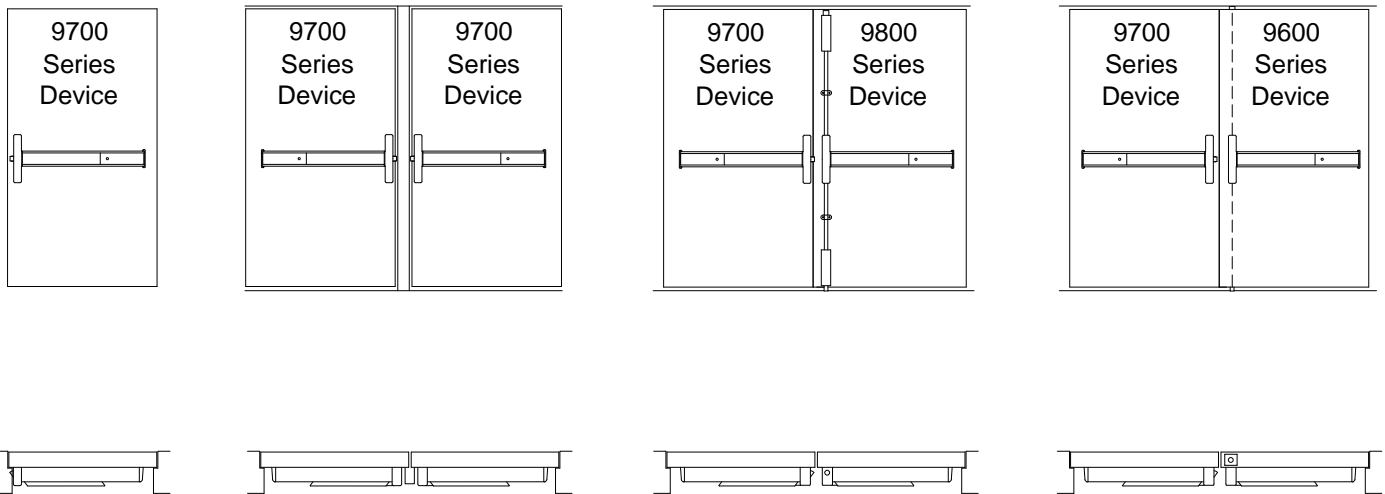

SPECIAL TOOLS FOR INSTALLATION

12-24 Tap, 10-32 Tap

Drill bits: 1/8", 3/8", #25, #16, #21

Hole saw 1 1/4" diameter for trim (if required) or jig saw.

5/32" Allen wrench for lever trim.

TYPICAL OUTSIDE TRIM INSTRUCTIONS

Note: When used with narrow stiles, consult door manufacturer for compatibility.



LHRB TRIM SHOWN RHRB OPPOSITE

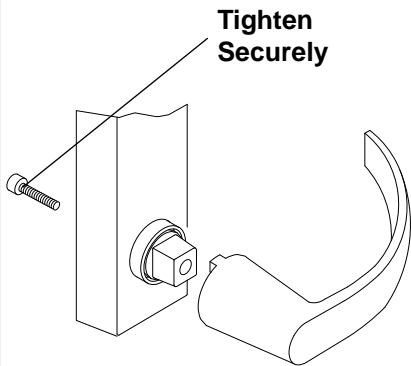
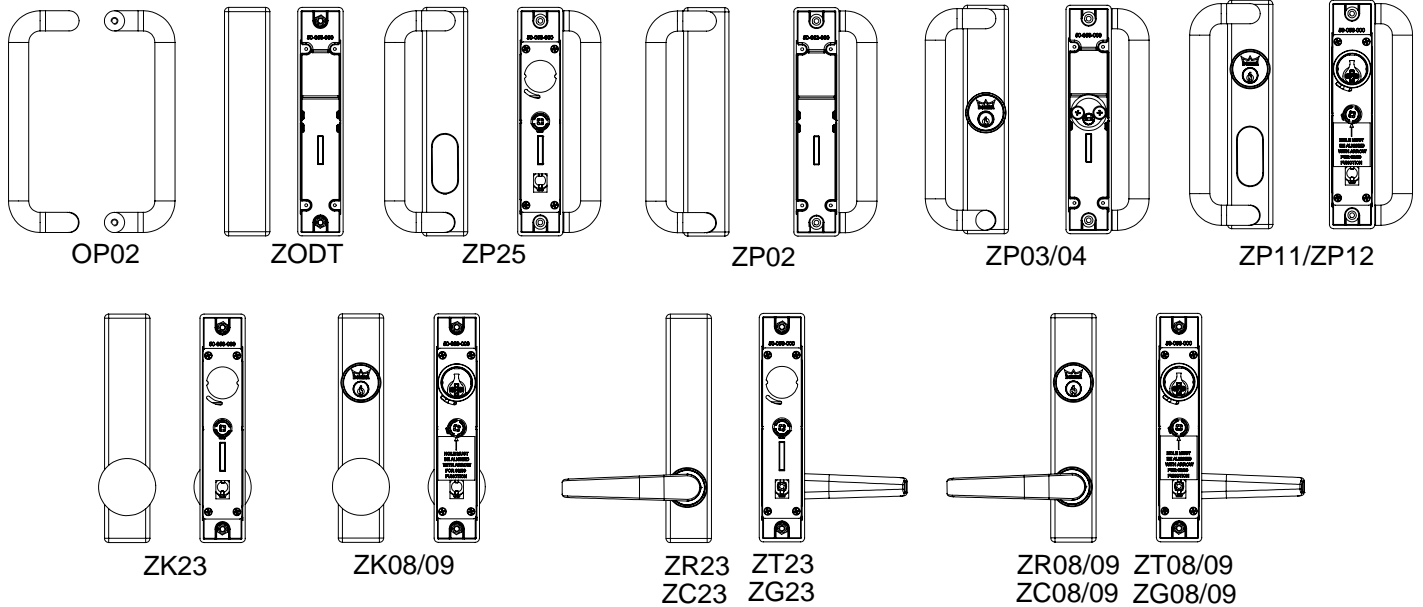

All trims are free wheeling.
(Handle will rotate when locked.)

IMPORTANT

Note: All lever handles except for "clutch" are shipped unattached. To install; **Place handle in desired position and attach with allen screw located in back of trim plate. 5/32"** Allen wrench required.
To change hand on "clutch" trim rotate and "break" lever around to desired hand.

Conventional 1 1/8" rim cylinder #80R20SC with tail piece, keyed differently to a random combination supplied with functions "03" & "04" trim unless otherwise noted.

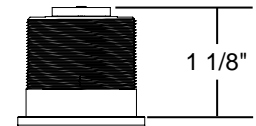
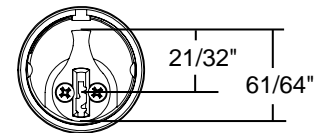

Conventional 1 1/8" mortise cylinder #90X13SC118 supplied with DORMA #13 cam, keyed differently to a random combination supplied with functions "08" & "11" trim unless otherwise noted.

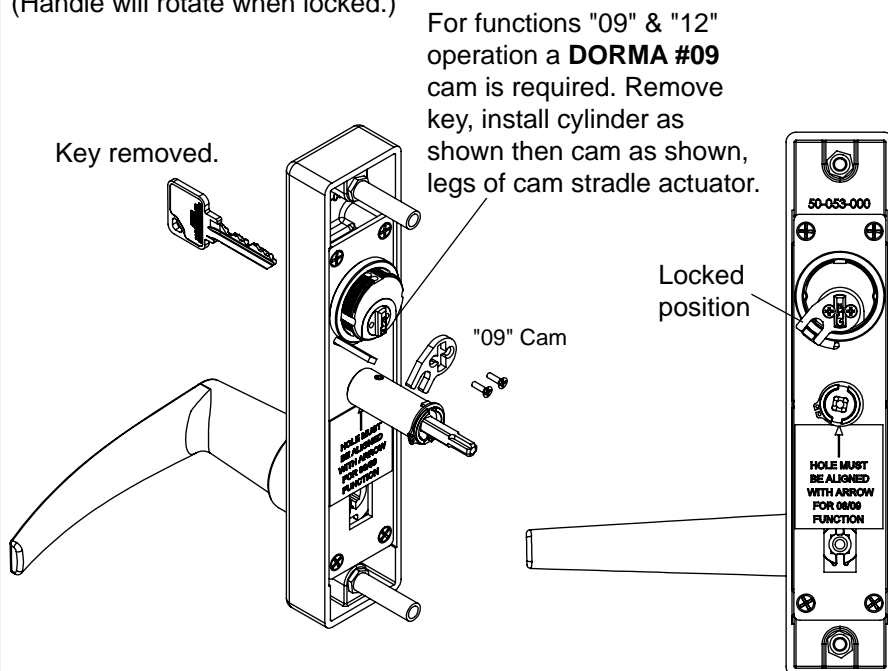

ADDITIONAL DOOR PREP REQUIREMENTS

9700/F9700

Rim Exit Device

RHR Shown

LHR Opposite

Required for "03" & "04" function on device
with cylinder only and no trim.

(NOT TO SCALE)

NOTE: "04" function not available on fire rate device. "Fire rated devices can not be dogged."

NOTE: If using 80CK cylinder adapter kit with trim; hole diameter required is 1 3/8".

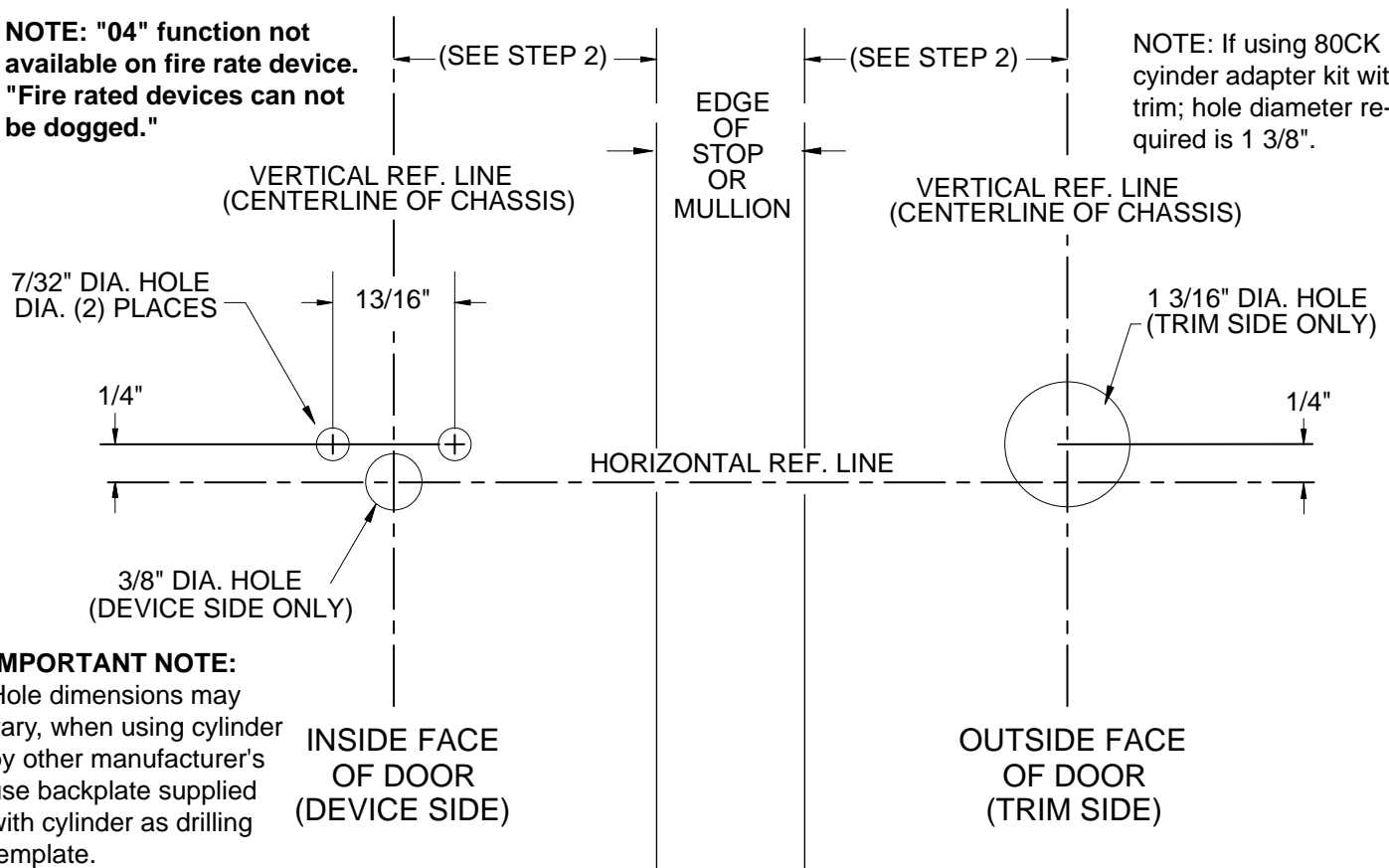

IMPORTANT NOTE:
Hole dimensions may vary, when using cylinder by other manufacturer's use backplate supplied with cylinder as drilling template.

1 Open box, layout all parts and verify prior to starting installation. See page (1) one for parts.
Note: If this is a retro-fit from current 5300 series see page 12 prior to proceeding.

2 Door preparation

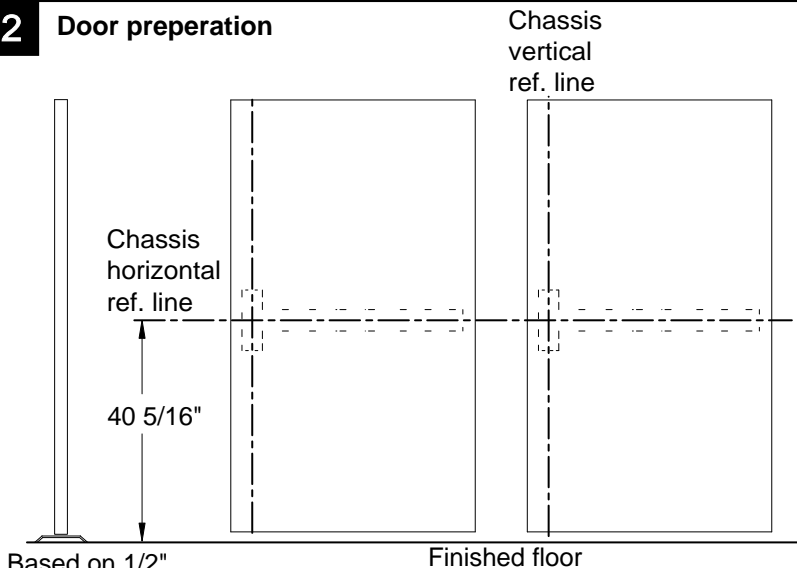

Based on 1/2" threshold and 3/16" clearance between threshold and door after door is hung.

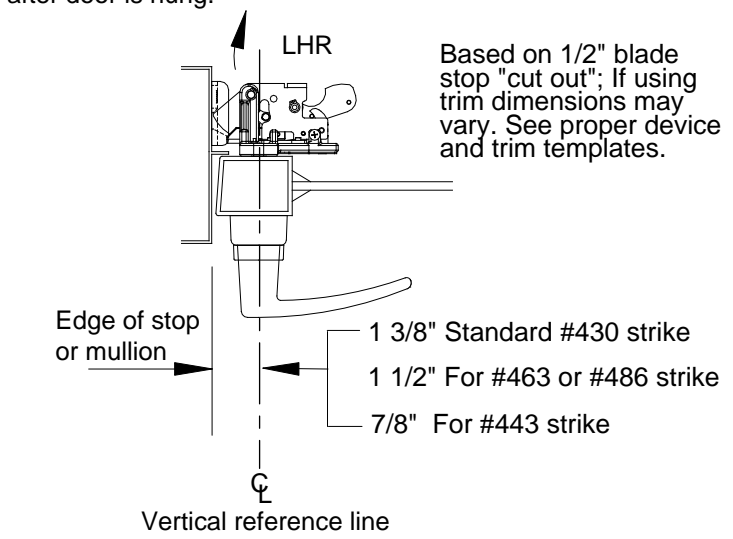
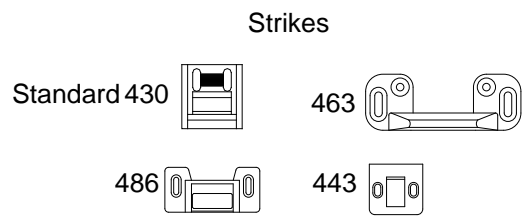

Based on 1/2" blade stop "cut out"; If using trim dimensions may vary. See proper device and trim templates.

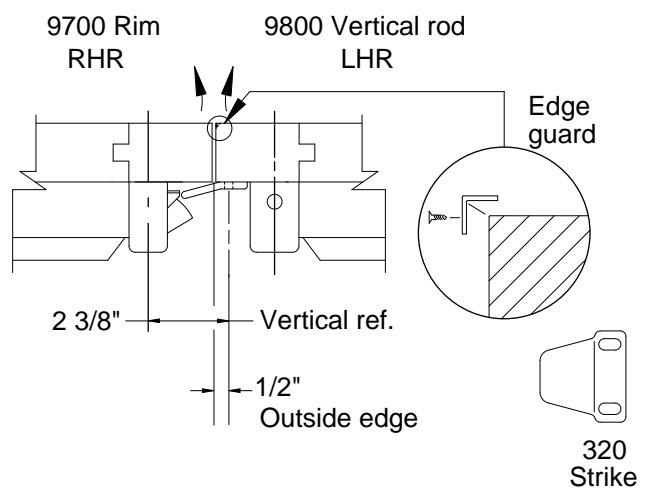

Backset or vertical reference is measured from outer edge of door as shown. Minimum stile is less glass stop.

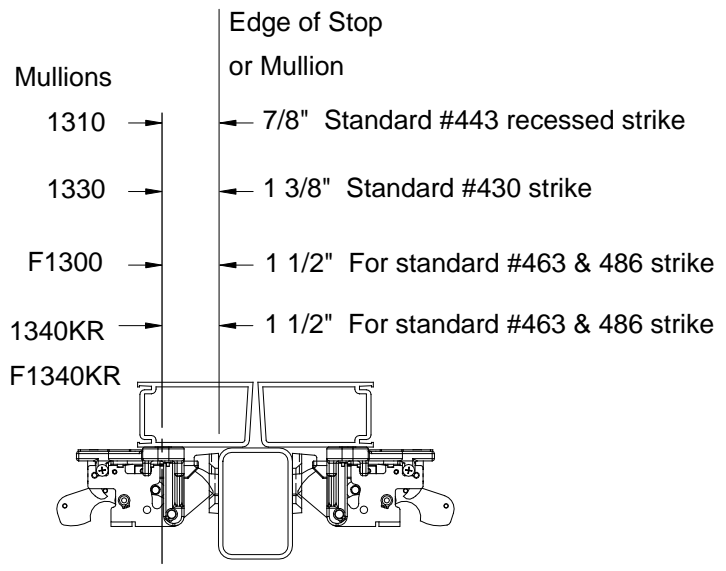
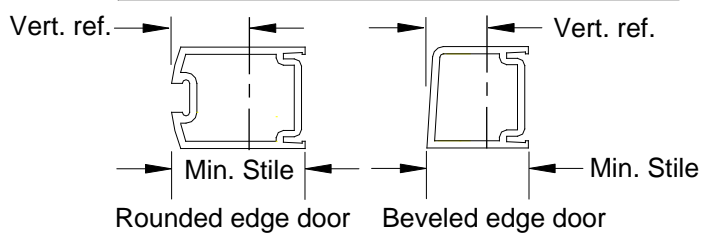

Type of installation	Minimum vertical ref. of chassis	Minimum Stile	
		Pull only	"Z" trim
Single door 1/2" blade stop	1 3/8"	2 "	2 3/16"
Pairs and double egress	1 1/4"	1 5/8"	2 1/8"

3 Prepare frame for strike

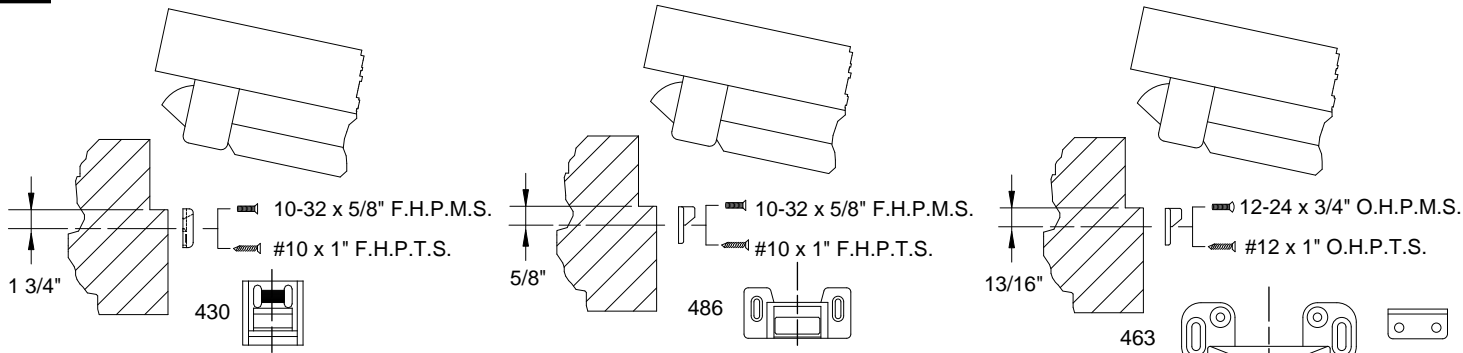

For metal frame: No. 21 drill x 10-32 tap
 For wood frame: 1/8" drill for pilot hole

For metal frame: No. 16 drill x 12-24 tap
 For wood frame: 1/8" drill for pilot hole

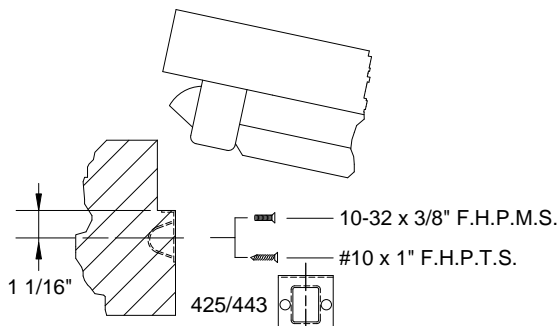

For metal frame: No. 21 drill x 10-32 tap
 For wood frame: 1/8" drill for pilot hole

Strike angle
 (Fire rated device only)
must be installed on
 rated openings.

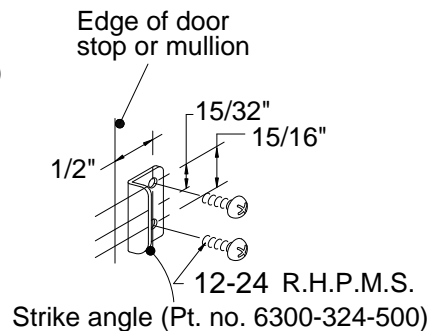

4 If not done layout device on door using drilling template T9700 located at rear of booklet. For additional templates contact DORMA at 1-800-523-8483 or www.dorma-usa.com

Refer to carton label for model and trim number prior to drilling.
 Prepare mounting holes and cut-outs per template.

VERTICAL REF. LINE
 (See Backsets on page 5.)

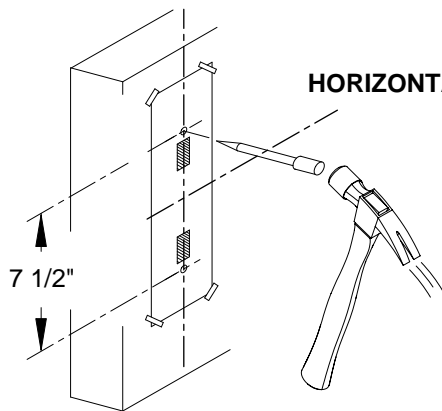

HORIZONTAL REF. LINE

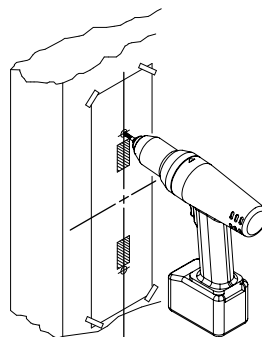

Verify all holes
 prior to drilling.

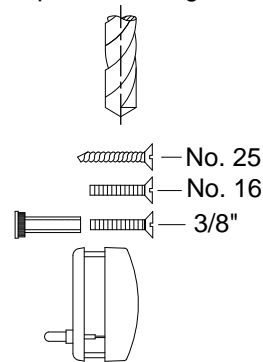

9 Prepare to install touch bar and rail on door.

NOTE: All dimensions are based on 1/2" stop height; Verify strikes, stile width, any trim and stop height prior to making any cuts. If cutting is required follow instructions below.

Size AA:

Fits 48" door opening without cutting.
Can be cut to fit a 32 1/2" minimum door opening.

Size BB:

Fits 36" door opening without cutting.
Can be cut to fit a 26 1/2" minimum door opening.

Size CC:

Fits 36" door opening with out cutting.
Using a shorter touch pad then the standard "B" size allows it to be cut to 23 1/2" door opening.

Note: Models with prefix options such as "ES", "DE" etc. may not be cut down to minimums shown to left. Consult factory or catalog for details.

Verify device length with box label; "AA", "BB" or "CC", ie. 9700BB

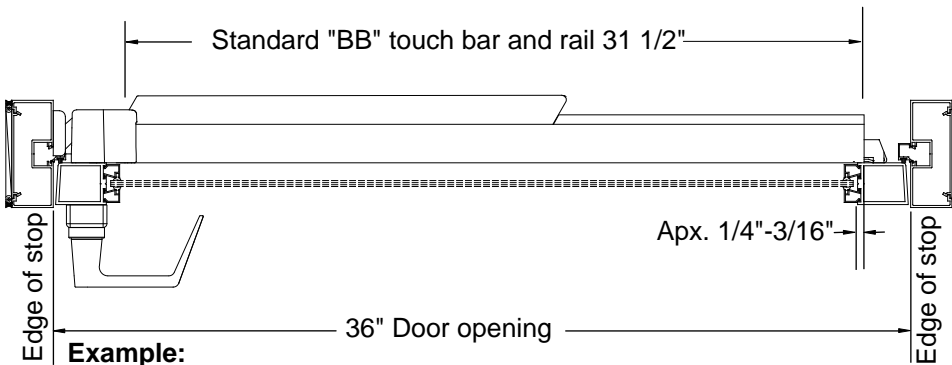

Note: If door opening width is less then standard touch bar will have to be cut down. ie: door opening width 34" subtract 2" from rear of touch bar and rail, tape and cut to length as shown.

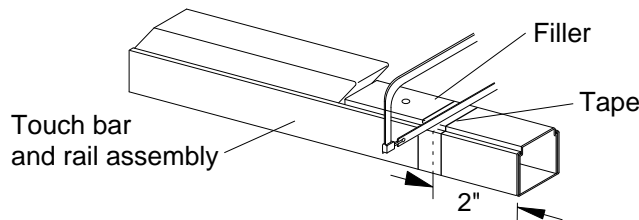

IMPORTANT

Use caution when cutting touchbar and rail to size on models with "ES", "MS", "LM" or "DWA" prefix options. These units contain internal wiring. For models with prefix options "BPA", BPAR" or "DE" remove filler containing electronics before cutting.

10 Secure chassis to door as shown.

Metal - (2) 12-24 x 1 1/2" R.H.P.M.S.
Wood - (2) #12 x 1 1/4" R.H.P.T.S.
(For other options; trim, thru bolts, etc. see below.)

For 3 1/2" stiles or less on aluminum doors, place shim under chassis prior to mounting on door.
(Finished side to outside face.)

Optional mounting

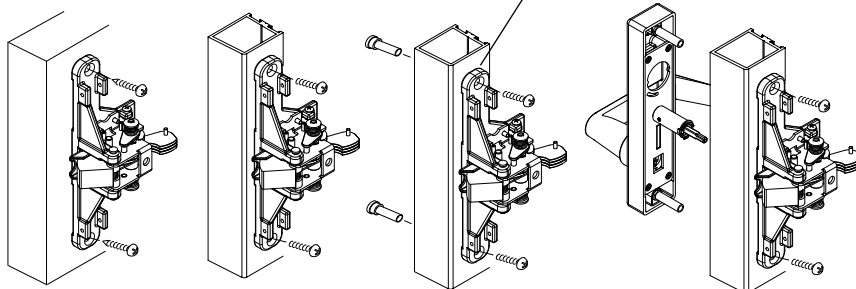

F9700 Series chassis assembly

Strike angle
(Must be installed)
(2) 12-24 F.H.P.M.S.

#463 Strike

(4) 12-24 O.H.P.M.S.

(2) 12-24 R.H.P.M.S.

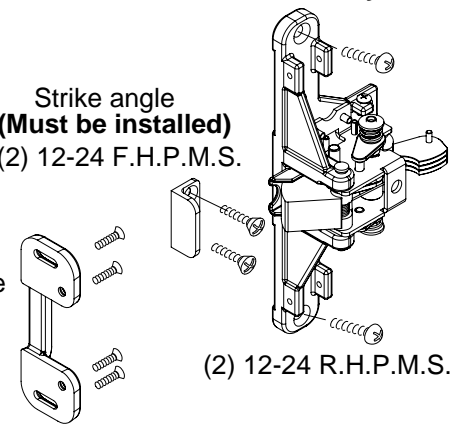

11 Install touch bar and rail assembly and end cap to door.

Remove two 8-32 screws from chassis, slide touch bar and rail assembly under rear of chassis. **Note: If device has prefix "ES" ensure that pins in lever bolt align with slots in actuator located inside nose of touch bar.** See instruction sheet IES-7 packed with device. Install (2) two 8-32 x 3/8" P.H.P.M.S. to secure touchbar to chassis.

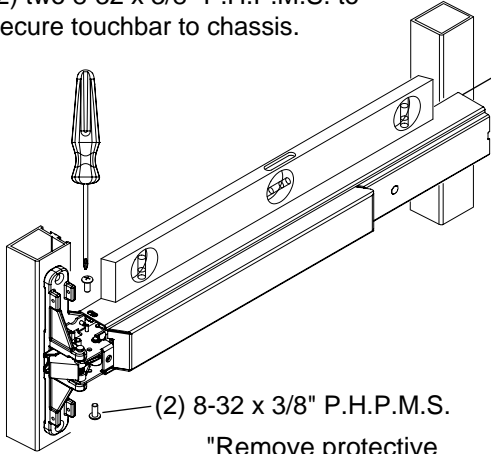

(2) 8-32 x 3/8" P.H.P.M.S.

"Remove protective covering from the touchbar and rail assembly prior to installing on door."

Hold rear mounting bracket tightly against door and rear of rail. Mark (2) two holes and drill per chart. Secure with proper fasteners.

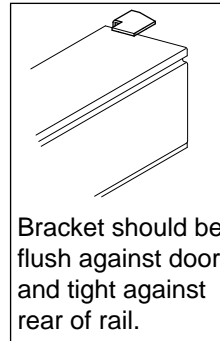
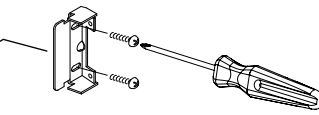



Bracket should be flush against door and tight against rear of rail.

NOTE: If carton label list prefix; "ES", "MS", "LM", "BPA", "BPAR", "DWA", "LM/MS/BP" or "CD" prefix see Options pages at rear.



 — 1/8" Drill 1" Deep (Wood)

 — No. 16 Drill - 12-24 Tap (Metal)

 — 3/8" Dia. (Thru bolts)

Metal/thru-bolts - (2) 12-24 x 1" F.H.P.M.S.
Wood - (2) #12 x 1 1/4" F.H.P.T.S.

For the following models prefixes: "ES", "MS", "LM" or "DWA" drill an additional 1/2" diameter hole as shown. See options pages at rear for additional information.

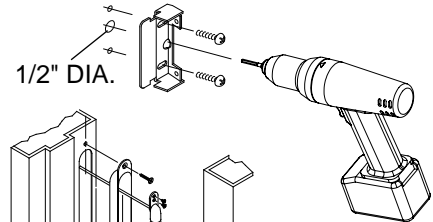

1/2" DIA.

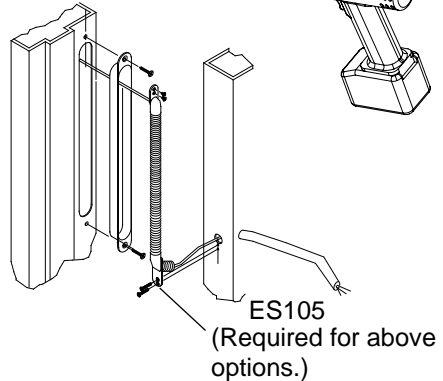

ES105
(Required for above options.)

12 Install center case cover and end cap.

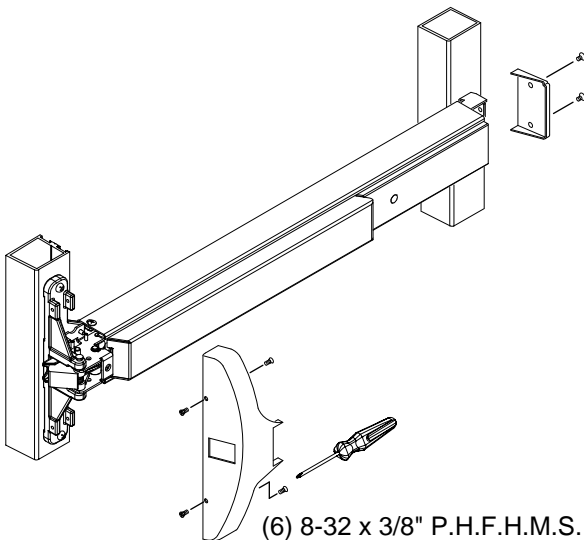

(6) 8-32 x 3/8" P.H.F.H.M.S.

Start all (4) screws prior to tightening.

13 Check dogging operation (if equipped).

Standard hex key dogging, depress touch bar, insert supplied hex key and rotate clock wise to dog and counter clock wise to undog.

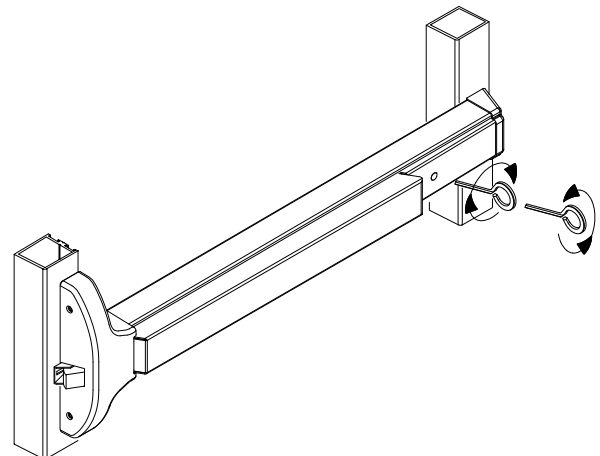

OPTIONS

"CD" (CYLINDER DOGGING) OPTION:

Cylinder dogging installation instructions & cylinder specifications.

NOTE: Touch bar must be in dogged down position, to remove the rear filler panel.

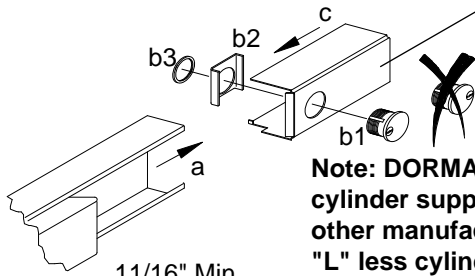

Note: DORMA mortise cylinder supplied. To use other manufacture cylinders, "L" less cylinder is available.

1 1/16" Min

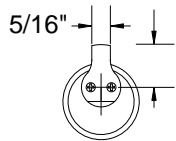

1" Min. to 1 1/8" Max.

Note: When using IC core cylinders, ensure that cam is in proper position prior to installing the new core.

Witness Marks

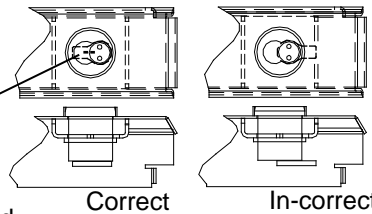

Correct

In-correct

Useable Cams	
Arrow	001
Assa	Std. (Yale)
Best	C136
Corbin	A02
Falcon	12667-3
DORMA	10
Ilco/Unican	SC1
Lori	SC1 4200-82-2002 Std.
Sargent	13-0664 or 13-0660
Schlage	001
Yale	2160

"LM" (LATCH MONITOR) OPTION:

Latch monitor: Monitors movement of bellcrank, with or without depressing of touch bar.

Can be wired normally open or normally closed.

***NOTE:** Use caution when cutting touch bar and rail to length. Additional hole required see **step 11**.

NOTE: Touch bar must be in dogged down position, to remove the rear filler panel.

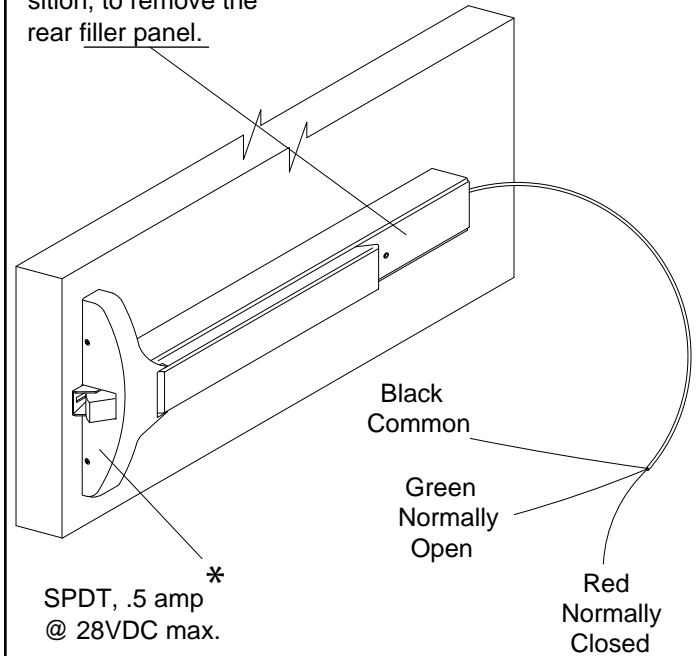

SPDT, .5 amp @ 28VDC max.

Black Common

Green Normally Open

Red Normally Closed

"BPA" & "BPAR" (ALARM) OPTION: FOR DIRECT WIRED SEE NEXT PAGE

BPA: Battery powered alarm, sounds continuous or until disarmed.

BPAR: Battery powered alarm, sounds for 4 minutes, automatically resets.

"Alarm mode set at factory."

SIZE A:

Will fit 48" door opening without cutting. Can be cut to fit a 37 1/2" minimum door opening.

SIZE B:

Will fit 36" door opening without cutting. Can be cut to fit a 31 1/2" minimum door opening.

SIZE C:

Will fit 36" door opening without cutting. Can be cut to fit a 28 1/2" minimum door opening.

***NOTE:** Use caution when cutting touch bar and rail to length.

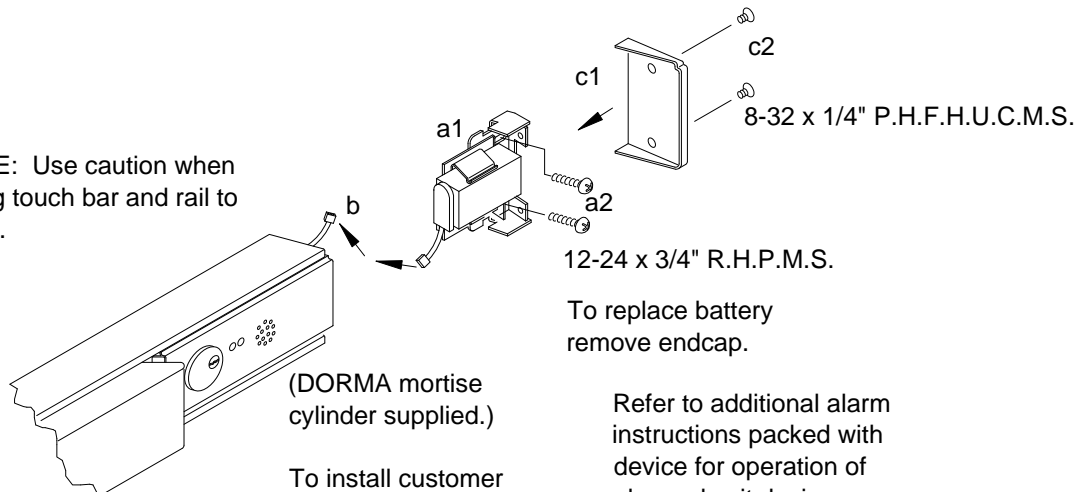

12-24 x 3/4" R.H.P.M.S.

To replace battery remove endcap.

(DORMA mortise cylinder supplied.)

To install customer supplied cylinder, see cylinder dogging option at top of page.

Refer to additional alarm instructions packed with device for operation of alarmed exit device.

OPTIONS

"ES" (ELECTRIC LATCH RETRACTION) OPTION:

Electrically retracts latchbolt(s) when energized by power supply.

REQUIRES DORMA PS501 POWER SUPPLY AND ES105 POWER TRANSFER.

PS501 Will operate (2) "ES" 9600 exit devices, but is capable of powering (2) additional devices by installing the optional "ES-2" card.

***NOTE:** Use caution when cutting touch bar and rail to length. Requires additional hole see **step 11**.

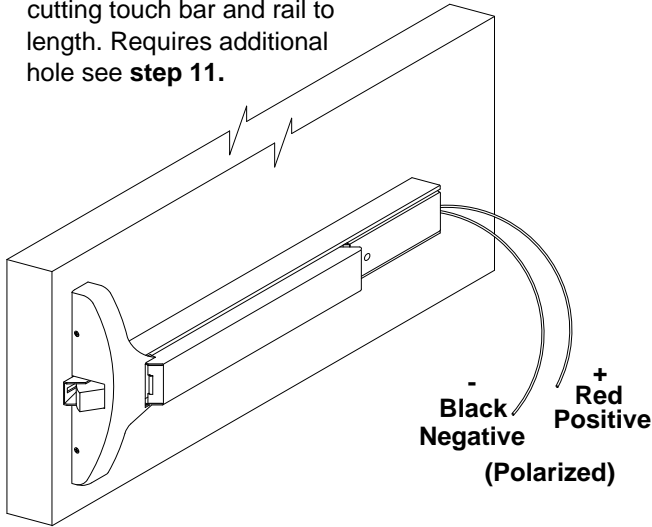

"DWA" (DIRECT WIRED ALARM) OPTION:

Connected to outside power source.
12-24 Volt AC/DC Power Supply.
i.e. DORMA ES100 etc.,
Contact DORMA for other power supplies available.

Refer to additional sheet IAL9000 packed with device for operation of alarmed exit device.

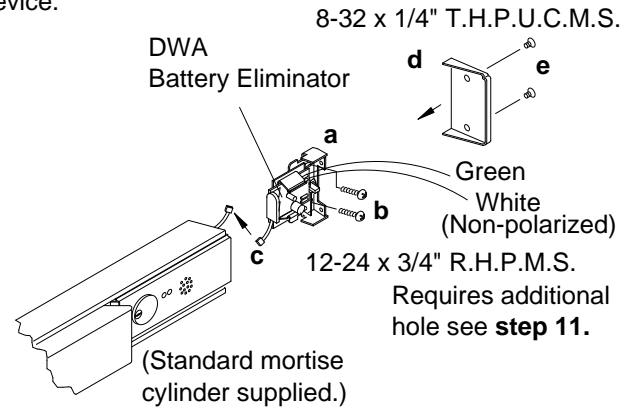

"MS" (MICRO SWITCH) OPTION:

"MS" option allows monitoring of touch bar during normal operation, or can be used as a signal switch for horn, light etc. Comes standard with (2) two micro switches. Both can be wired either Normally Open or Normally Closed. Can be added to device after installation.

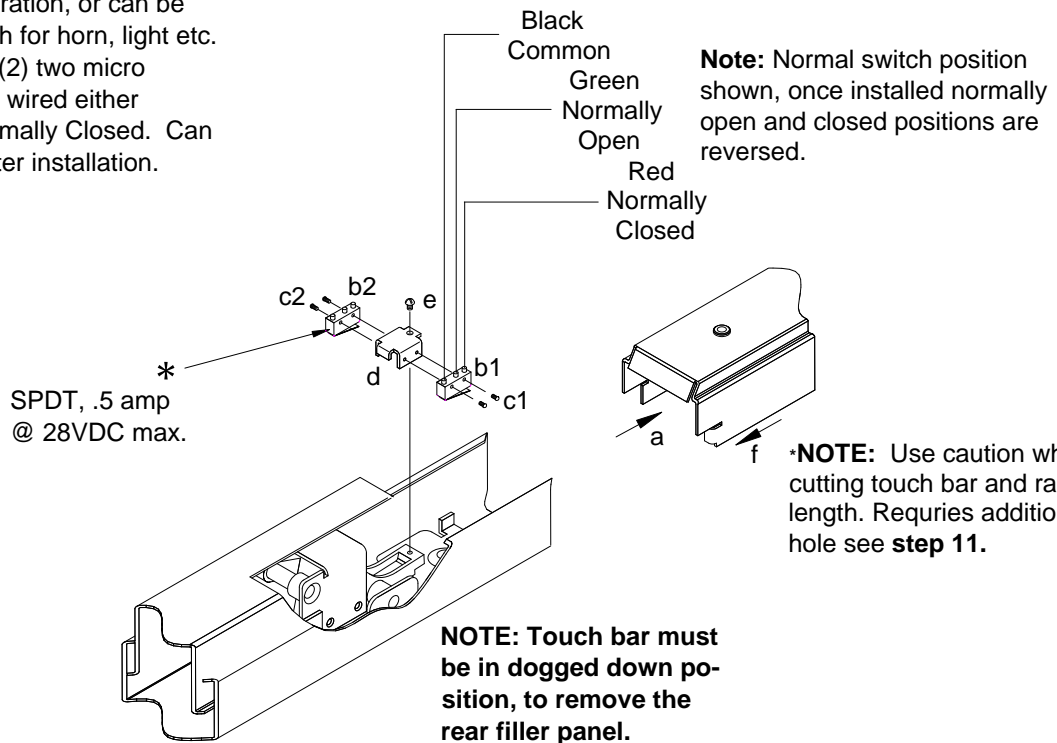

OPTIONS

"DE" (DELAYED EGRESS) OPTION:

Note: Refer to DE9000 Series Installation Instructions for additional instructions for installation and operation of the "Delayed Egress" exit device.

- 85 Decibel Alarm - Standard
- LED Status Indicator - Standard
- Nuisance Alarm - Standard
- Key Switch Control - Standard
- Remote Authorized Egress - Standard
- Remote Re-Arm - Standard
- Remote Bypass - Standard
- Door Position Input - Standard, DIP Switch Setting
- Auto Reset or Manual Reset, DIP Switch Setting
- Auto - Standard (Manual - in CA)
- Additional Form "C" Relays For Optional Horn etc.
(Rated 1 amp @ 30 vdc)

**REQUIRES DORMA
ES-100 24 VDC POWER SUPPLY.
One supply per device unless the
optional ES101 Time Delay is used
to sequence the arming of the two
devices.**

Easily accessible slide in and out electronics.
Meets UL & ANSI/BHMA requirements.

SIZE AA:
Will fit 48" door opening without cutting.
Can be cut to fit a 39 1/2" minimum door opening.
SIZE BB:
Will fit 36" door opening without cutting.
Can be cut to fit a 32" minimum door opening.

**NOTE: Some CA Codes may require
different verbiage; check local code re-
quirements prior to installing decal.**

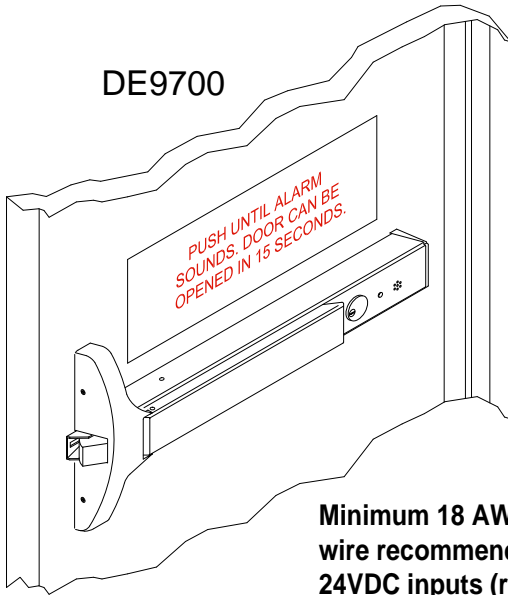

**Minimum 18 AWG
wire recommended for
24VDC inputs (red &
black) leads.**

**DORMA ES105
(Power Transfer
"Required")**

(12) Wire Connection
Bundle 22" in length.

Maximum Wire Length From Power Supply To Device & Back To Supply In Feet x Wire Gage/Size				
WIRE	18AWG	16AWG	14AWG	12AWG
FEET	25	50	75	100

* For 24VDC inputs only (red & black wires).

**Note: Wire run is from supply to device
and back to the supply.**

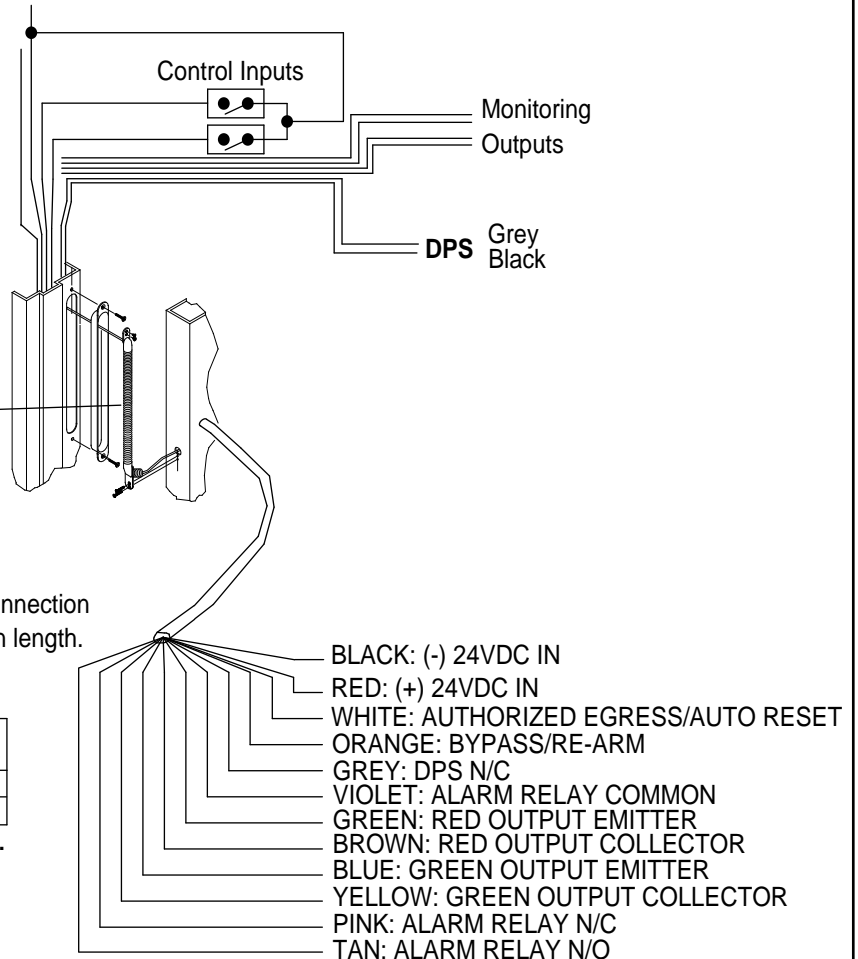

RETROFIT FROM EXISTING 5300 TO NEW 9700 MODEL

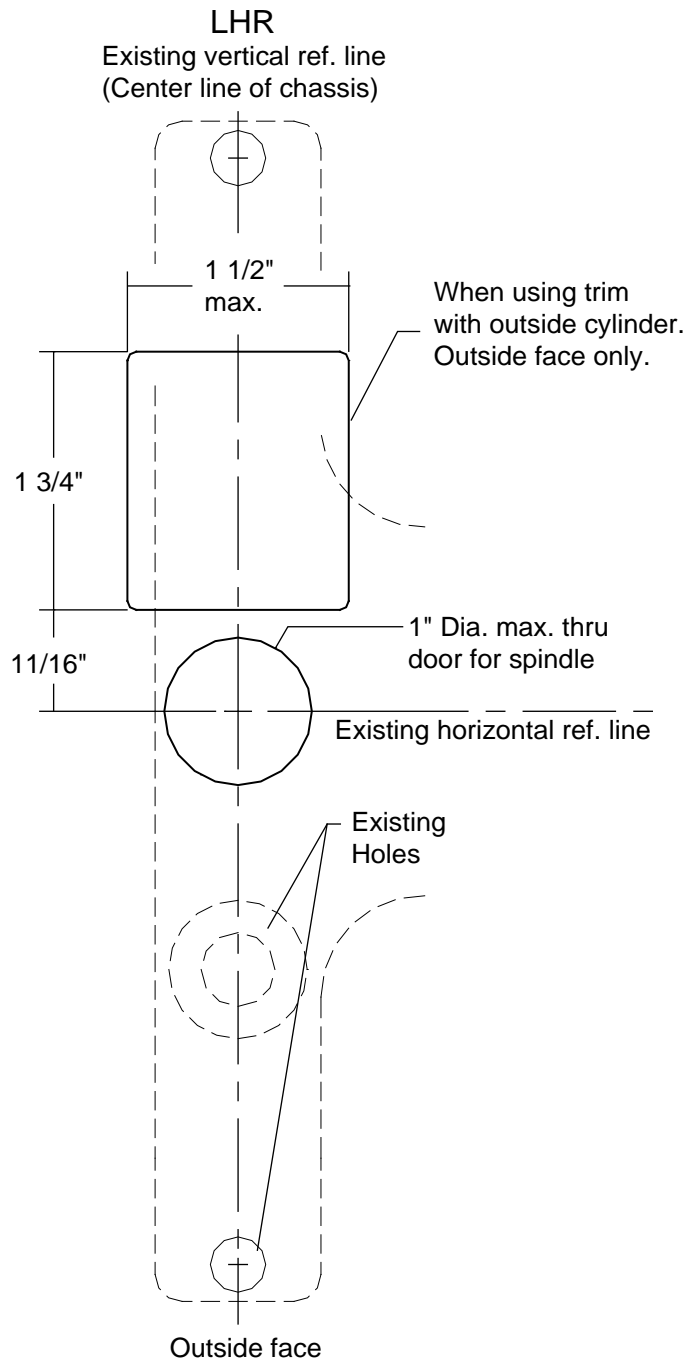

DO NOT SCALE

Additional installation instructions:

New "Z" trim required if using trim.

Existing strike may or may not have to be adjusted or relocated and replaced.

Install chassis assembly to door, install end cap bracket to door, hold touch bar and rail assembly in position aligning screw holes in rail with mounting screw location of chassis, mark a line on rear of rail where front edge of end cap bracket is then cut touch bar and rail assembly to length.

Install touch bar and rail to door then install all covers.

LHRB

VERTICAL REF. LINE
(CENTERLINE OF CHASSIS)

RHRB

VERTICAL REF. LINE
(CENTERLINE OF CHASSIS)



**EXIT DEVICE
9700/F9700 SERIES**

OUTSIDE
FACE ONLY

OUTSIDE
FACE ONLY

NOTE: FOR CYLINDER ONLY
FUNCTION SEE PAGE 4

HORIZONTAL REFERENCE LINE

**Drawing Not To Scale
Use for Reference Only**

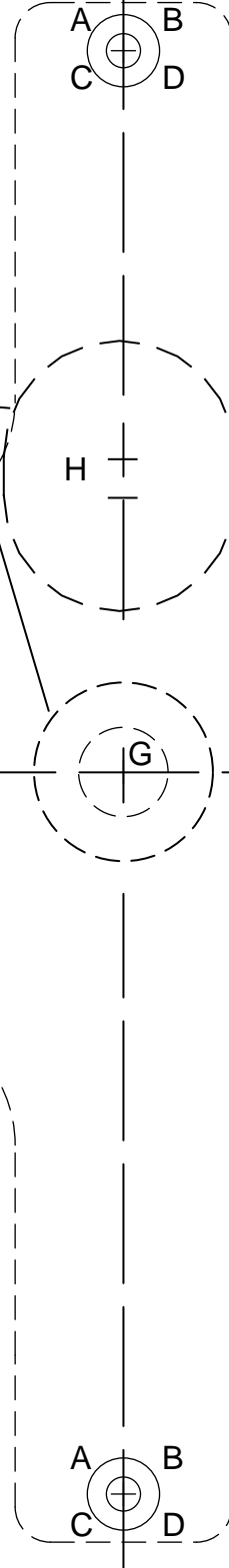
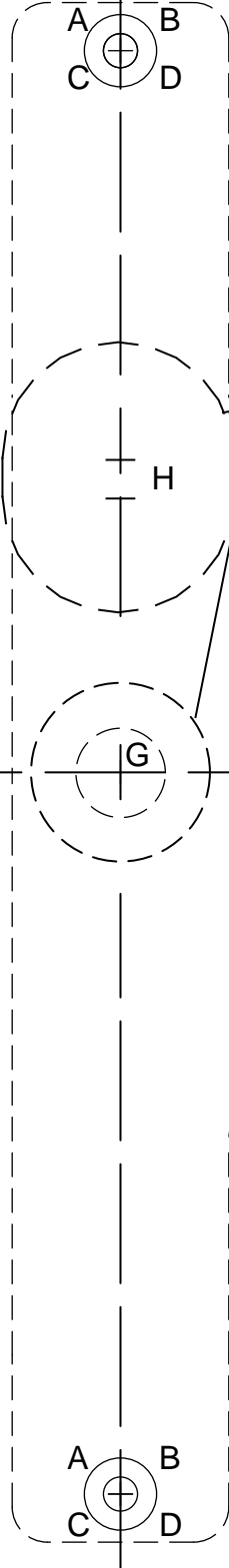
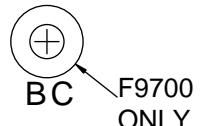
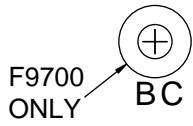
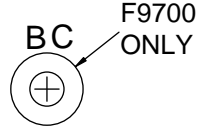
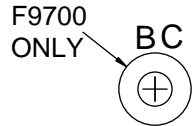

- A FOR WOOD DOOR No. 25 DRILL 1" DEEP
- B FOR METAL DOOR No. 16 DRILL 12-24 TAP
- C FOR SEX BOLT 3/8" DIA. HOLE THRU DOOR
- D FOR USE WITH TRIM 3/8" DIA. HOLE THRU DOOR
- G FOR KNOB/LEVER/THUMBTURN 1" DIA. OUTSIDE FACE
1/2" DIA. INSIDE FACE
- H FOR KNOB/LEVER/THUMBTURN 1" DIA. OUTSIDE FACE
1 1/2" DIA. x 1 3/4" HIGH FOR CYLINDER CLEARANCE