

## CENTER PIVOTED DOOR

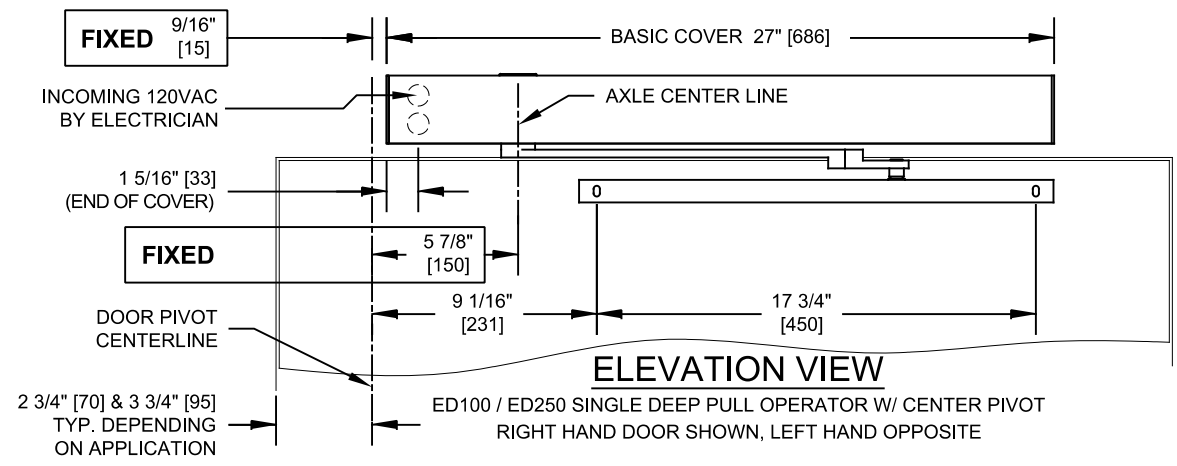

## HINGED DOOR

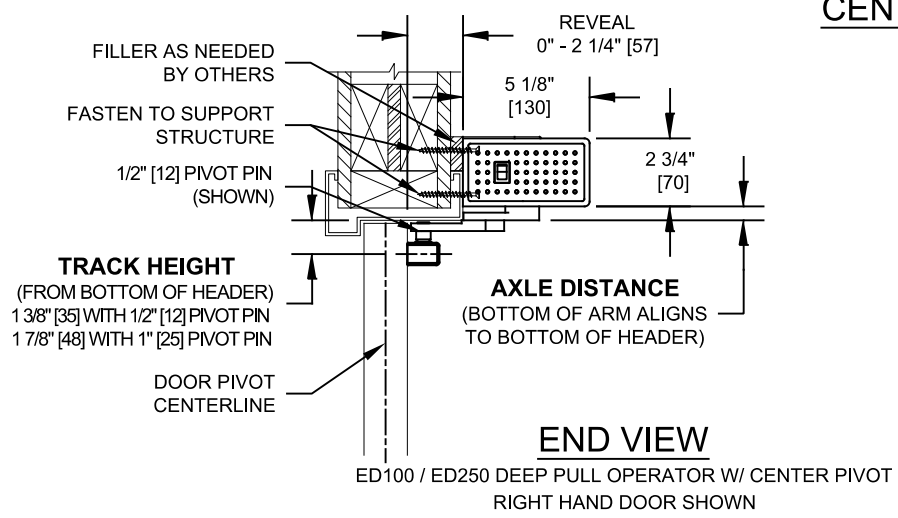
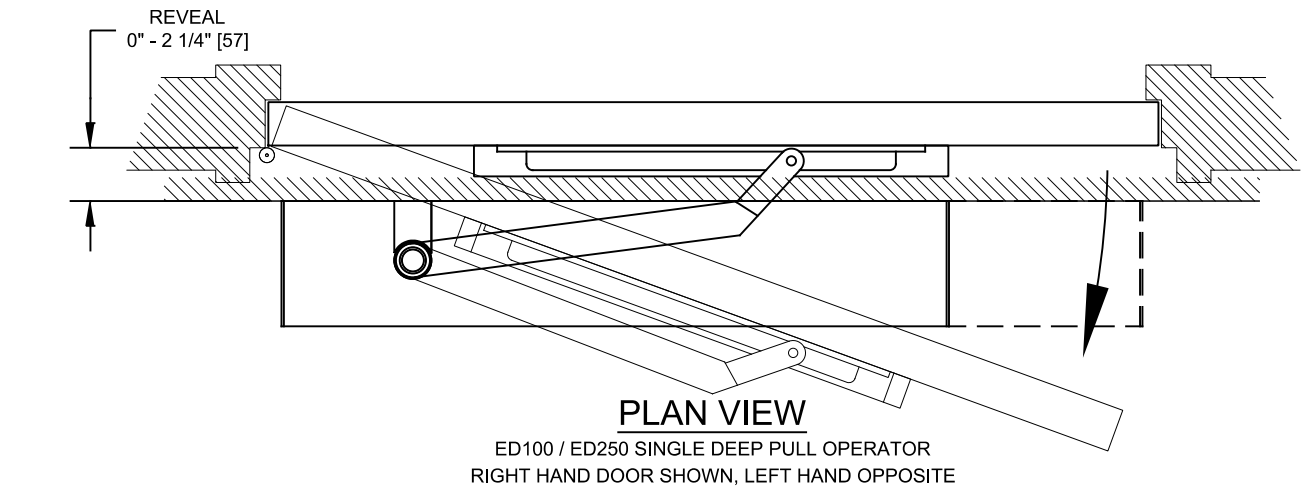
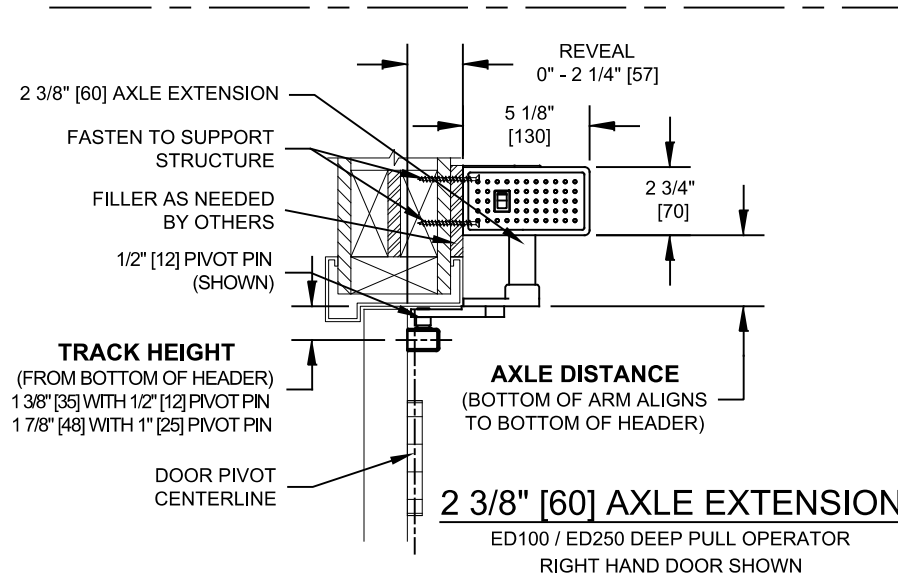
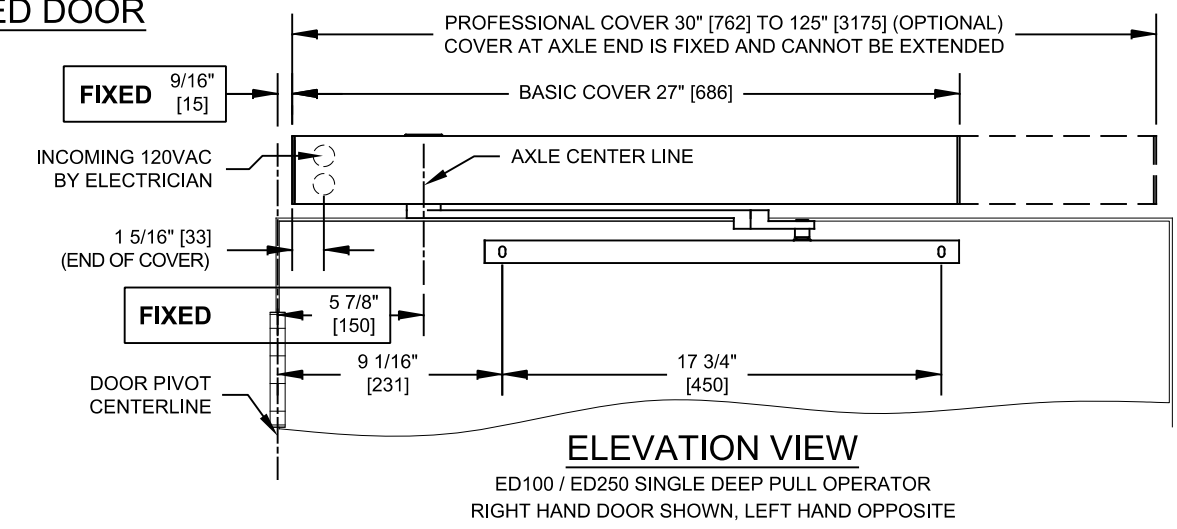
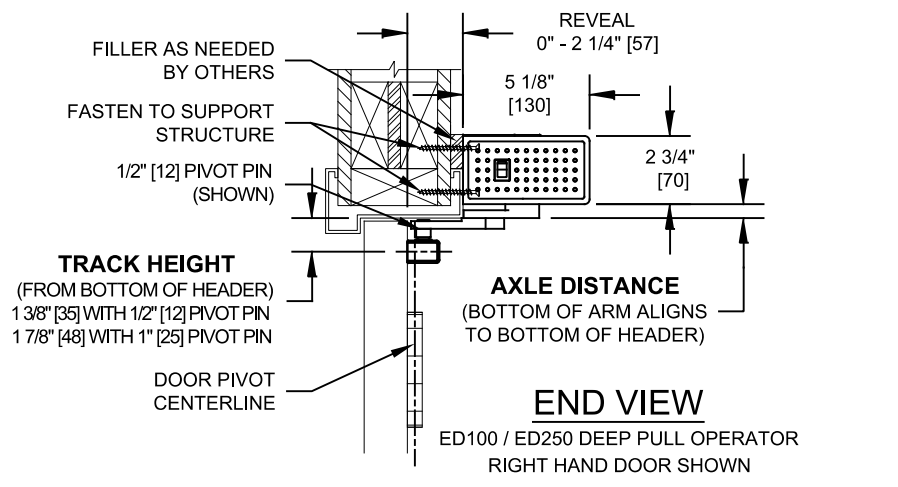

PULL AXLE EXTENSION	PULL AXLE DISTANCE	
FLUSH	9/16" [14]	STANDARD (SHOWN)
13/16" [20]	1 5/16" [34]	
1 3/16" [30]	1 3/4" [44]	
2 3/8" [60]	2 15/16" [74]	
3 9/16" [90]	4 1/8" [104]	FOR ED250 ONLY

- The ED100 & ED 250 Single Deep Pull package consists of:
  - Operator:
    - ED100 LE / FE door leaf:
      - Maximum 43" [1092] wide, 220 lbs [100].
    - ED250 LE door leaf:
      - Maximum 38" [965] wide at 265 lbs [120].
      - Maximum 46" [1168] wide at 165 lbs [75].
    - ED250 FE door leaf:
      - Maximum 55" [1400] wide at 550 lbs [250].
      - Maximum 63" [1600] wide at 420 lbs [190].
    - Operator is NOT handed, can be Left or Right.
  - Standard Cover length at 27" [686] extruded aluminum with plastic endcaps.
  - Arm Kit:
    - Deep pull arm reveal = 0" to 2 1/4" [57] Max.
    - Standard flush axle extension kit.
  - Connection Kit:
    - #14 x 2-1/2" Phillips Flat Head Wood Screws.
    - #14 x 1-1/4" Phillips Flat Head Self Drilling Screws.
    - #8 x 1-3/4" SPAX pan head wood screws to mount track.
    - M5 x 0.8 x 30mm pan head machine screws to mount track.
  - Required ANSI labels.
- Finishes:
  - Extruded Cover:
    - Clear (BHMA 204) or Dark Bronze (BHMA 313) anodized finish (Standard).
    - Custom painted.
    - Custom anodized.
    - Cladding.
  - Endcaps:
    - Silver or black painted.
  - Arms:
    - Silver or black painted.
- Typical Package Options:
  - Professional cover (single) 30" [762] to 125" [3175].
  - dormakaba Upgrade cards. (See brochure for details).
    - FE upgrade card.
    - Fire Protection upgrade card.
    - Professional upgrade card.
    - Barrier-Free Toilet upgrade card.
  - Vario Cover Kit (a pair cover made with 2 singles) (see options page).
  - Axle extensions (See chart for available lengths).
  - Alternate pull arm with reveal = 0" to 1/8" [3] Max.
- Drawing Notes:
  - Drawing dimensions are in English & Metric units. Metric units are displayed as: 1" [25] millimeters.
  - Operator dimensions:
    - Width x Height x Depth: 27" [686] x 2 3/4" [70] x 5 1/8" [130].
    - Operator weight: 26.5 lb [12 kg].
  - Maximum opening angle of 110°.
  - See installation manual for further details.
- Power Requirements:
  - 120V +/- 10%, 50/60 Hz, 6.6A peak (per operator). Service to header by electrician.
- Standards of Compliance:
  - UL 325 & CSA 22.2 (listed with ETL).
  - Designed to comply with these standards depending on installation and application:
    - International Building Code (Section 1008).
    - ANSI/ BHMA 156.10 (Requires additional overhead activation and safety sensors) (May also require guide rails depending on configuration).
    - ANSI/ BHMA 156.19 (Requires additional knowing activation devices not shown in drawing).
    - NFPA 101 Life Safety Code (Section 7.2.1.9).
  - Refer to Local, State, National or AHJ. Building Code for minimum door height and minimum/maximum width allowable for egress requirements.
  - Tested to UL 10B 90 min. fire rated door assembly.
- Contact dormakaba Architectural Services for more information:
  - Phone: 1-844-SPEC-NOW (1-844-773-2669)