

NOTES:

1. DRAWING IS NOT TO SCALE.
2. DIMENSIONS ARE IN INCHES/[MM].

WOOD DOORS FOR:
J310, J353 WITH 4" CENTERS
FACE PLATE 1-1/8" FLAT OR BEVELED

DORMA USA, Inc.
Reamstown, PA 17567

Toll-Free: (800) 523-8483
Facsimile: (800) 274-9724

Always consult DORMA's web site for latest
template at www.dorma.com.

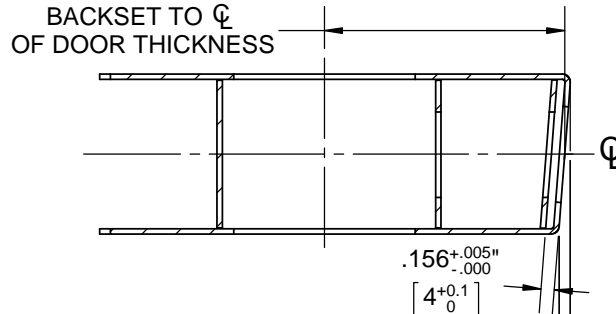

BEVELED EDGE DETAIL

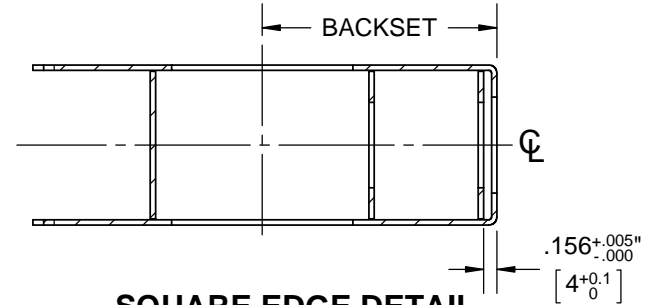

SQUARE EDGE DETAIL

NOTE: LATCH CASE AND LOCK CHASSIS SUPPORTS MUST BE DESIGNED TO PROVIDE ADEQUATE STRENGTH TO SUPPORT THE LOCK WITHOUT CRUSHING THE DOOR.

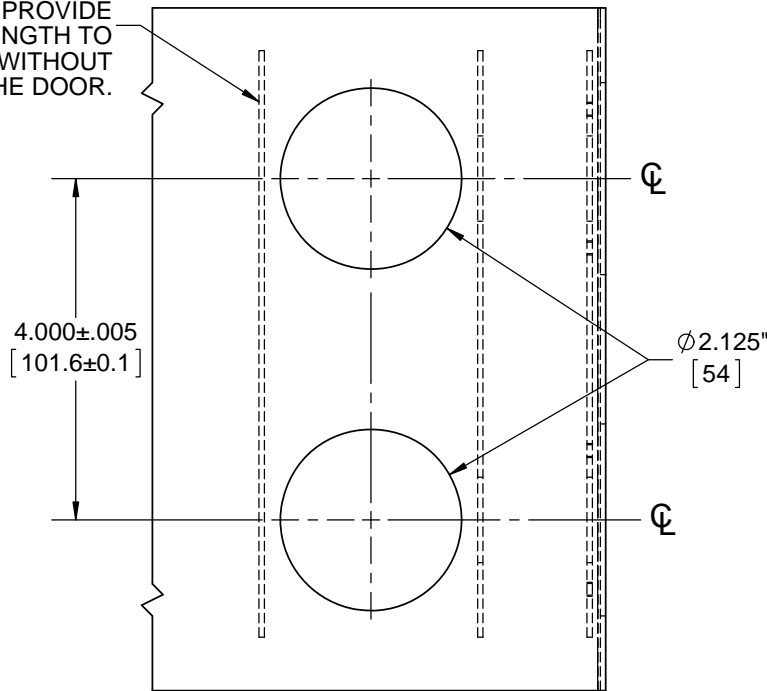

DOOR FACE DETAIL

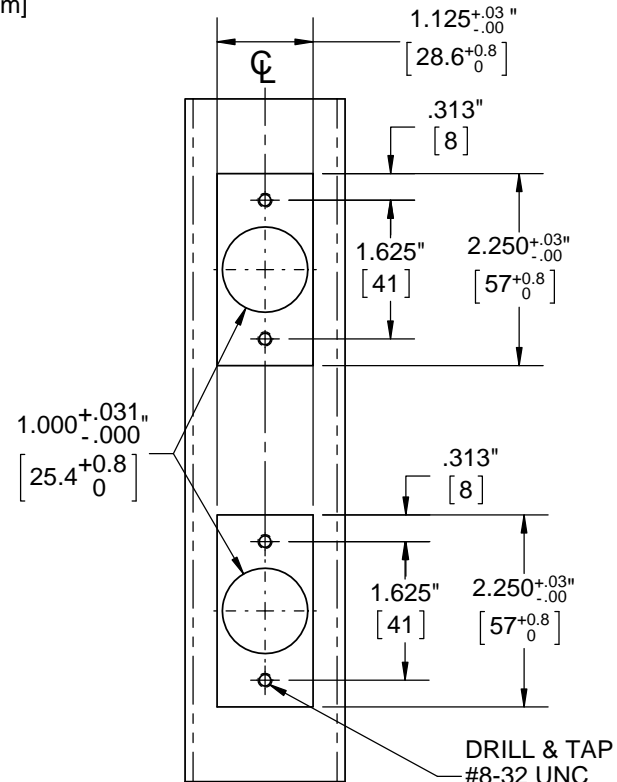

DOOR EDGE DETAIL

DRILL & TAP
#8-32 UNC
4 PLCS

NOTES:

1. DRAWING IS NOT TO SCALE.
2. DIMENSIONS ARE IN INCHES/[MM].

METAL DOORS FOR:
J310, J353 WITH 4" CENTERS
FACE PLATE 1-1/8" FLAT OR BEVELED

DORMA USA, Inc.
Reamstown, PA 17567

Toll-Free: (800) 523-8483
Facsimile: (800) 274-9724

Always consult DORMA's web site for latest template at www.dorma.com.