

NOTES:

1. DO NOT SCALE DRAWING.
2. DIMENSIONS ARE IN INCHES/(MM).
3. RIGHT HAND DOOR SHOWN.
4. CAUTION: SEX NUTS ARE REQUIRED FOR ATTACHMENT OF COMPONENTS TO UNREINFORCED DOORS AND TO WOOD OR PLASTIC FACED COMPOSITE TYPE FIRE DOORS, UNLESS AN ALTERNATIVE METHOD IS IDENTIFIED IN THE INDIVIDUAL DOOR MANUFACTURER'S LISTINGS.
5. ADJUST CLOSER SPRING TENSION FOR PROPER CLOSING AND LATCHING OF DOOR.
6. ADEQUATE REINFORCEMENT BY OTHERS REQUIRED TO INSTALL TRACK IN POCKET.
7. POCKET DEPTH IS MEASURED FROM PULL SIDE FACE OF DOOR AT MAXIMUM OPENING.
8. MAXIMUM OPENING IS 91° TO 119° DEPENDING ON DOOR HANGING MEANS.

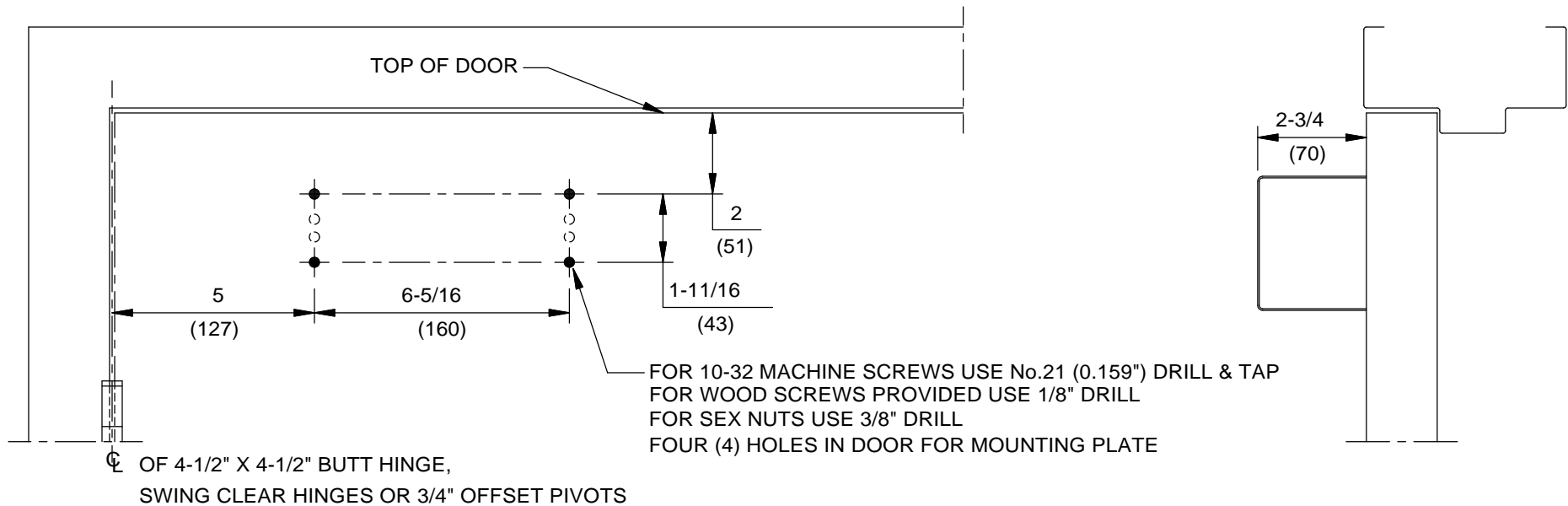

DOOR CLOSER MODELS: TS93-5 PKT 90/119
 90° POCKET DOOR INSTALLATION (PULL SIDE MOUNT)
 TRACK SURFACE APPLIED TO POCKET WALL



DORMA Architectural Hardware
 Reamstown, PA 17567

