

ICU300 / ICU300T

Manual sliding doors with trackless guide system

Installation Manual

DL3107-030 – 05-2022

| EN |

dormakaba 

Tools Required:

Screwdrivers

- Small Straight (Flat Blade) - for Terminal Block wiring
- #2 Phillips (Crosspoint) - for various #8, #10, and #14 screws

Wrenches / Sockets

- 15/16" wrench - for carrier and anti-rise roller adjustment

Allen Wrenches

- 1/8" - for "SO" arm stop & "SX" bottom pivot
- 5/32" - for "SO" top pivot
- 5mm (3/16") - for "SO" arm pivot screw
- 5/16" - for carrier and anti-rise roller adjustment

Electric Drill with the following drill bits -

- 5/32" (or #22) - for installing #10 sheet metal screws into adjacent storefront
- 13/64" (or #7) - for installing #14 sheet metal screws into adjacent storefront
- 1/4" - for clearance holes in jambs
- 82 degree Countersink

Impact Drill with the following masonry bits -

- 1/4" - for #10 screw anchors
- 5/16" - for #14 screw anchors

Level - suggested 4' minimum

Step Ladder - 4' or 6'

Tape Measure

Caulking and Application Gun

Electrical Wire Strippers /Cutters - for monitor wiring

Grease [to hold "SX" bottom guide block on shaft]

Suggested Fasteners Required - (Not supplied)

Jamb Attachment Screws -

- #14 X 2-1/2" PHSMS (Pocket Jambs)
- #14 X 3" FHSMS (Tube Jambs)
- Optional Anchors for masonry

Basement Bearing Plate Attachment Screws

- #10 X 1-1/2" FHSMS
- Optional Anchors for masonry

Header Attachment Screws

- #14 X 1-1/2" HHSMS
- #14 Flat Washer

Construction Shims - for squaring door frame in opening

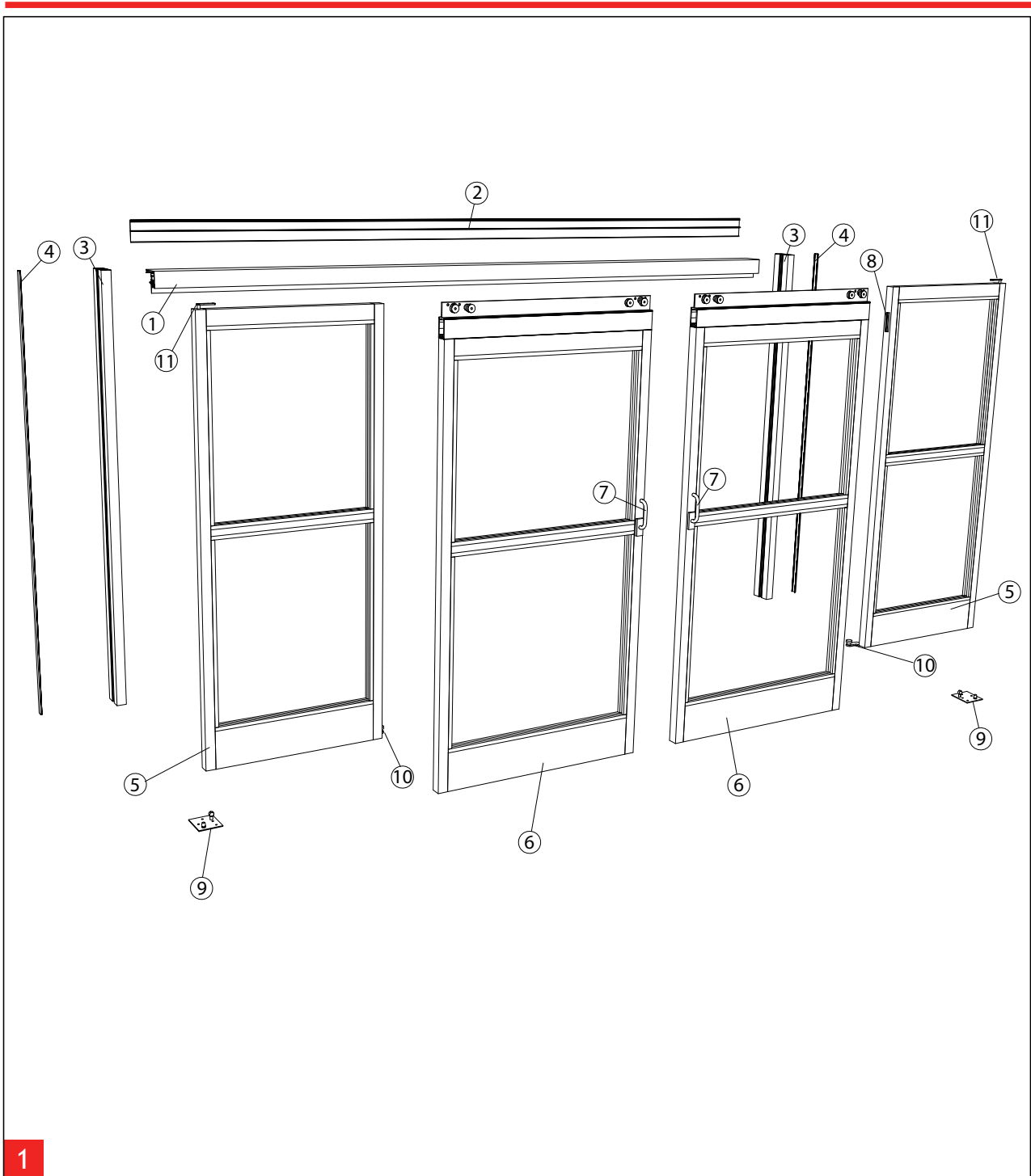

Components (2 Leaf) - Overview

- | | | |
|-------------------------|-----------------------|----------------------|
| ① Header | ⑤ Sidelight | ⑨ Base Bearing Plate |
| ② Header Closeout Cover | ⑥ Sliding Panel | ⑩ Floor Guide |
| ③ Jamb Tube | ⑦ Positive Latch Pull | ⑪ Bearing Pivot |
| ④ Cover Extrusion | ⑧ Flush Bolts | |

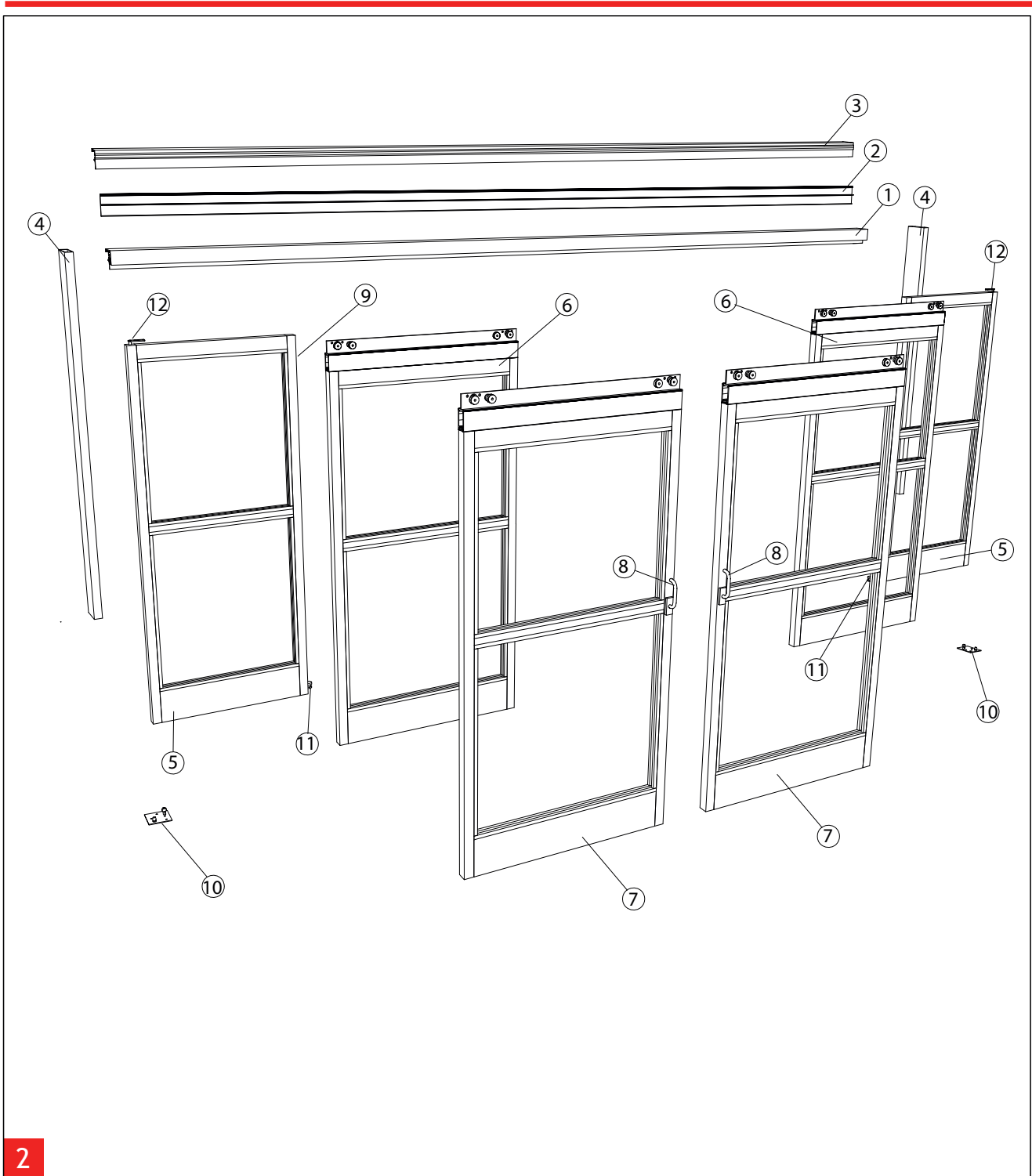

2

Components (4 Leaf) - Overview

- | | | |
|-------------------------|-----------------------|----------------------|
| ① Header | ⑤ Sidelight | ⑨ Flush Bolts |
| ② Header Closeout Cover | ⑥ “SX2” Sliding Panel | ⑩ Base Bearing Plate |
| ③ Outer Roller Track | ⑦ “SX1” Sliding Panel | ⑪ Floor Guide |
| ④ Jamb Tube | ⑧ Positive Latch Pull | ⑫ Bearing Pivot |

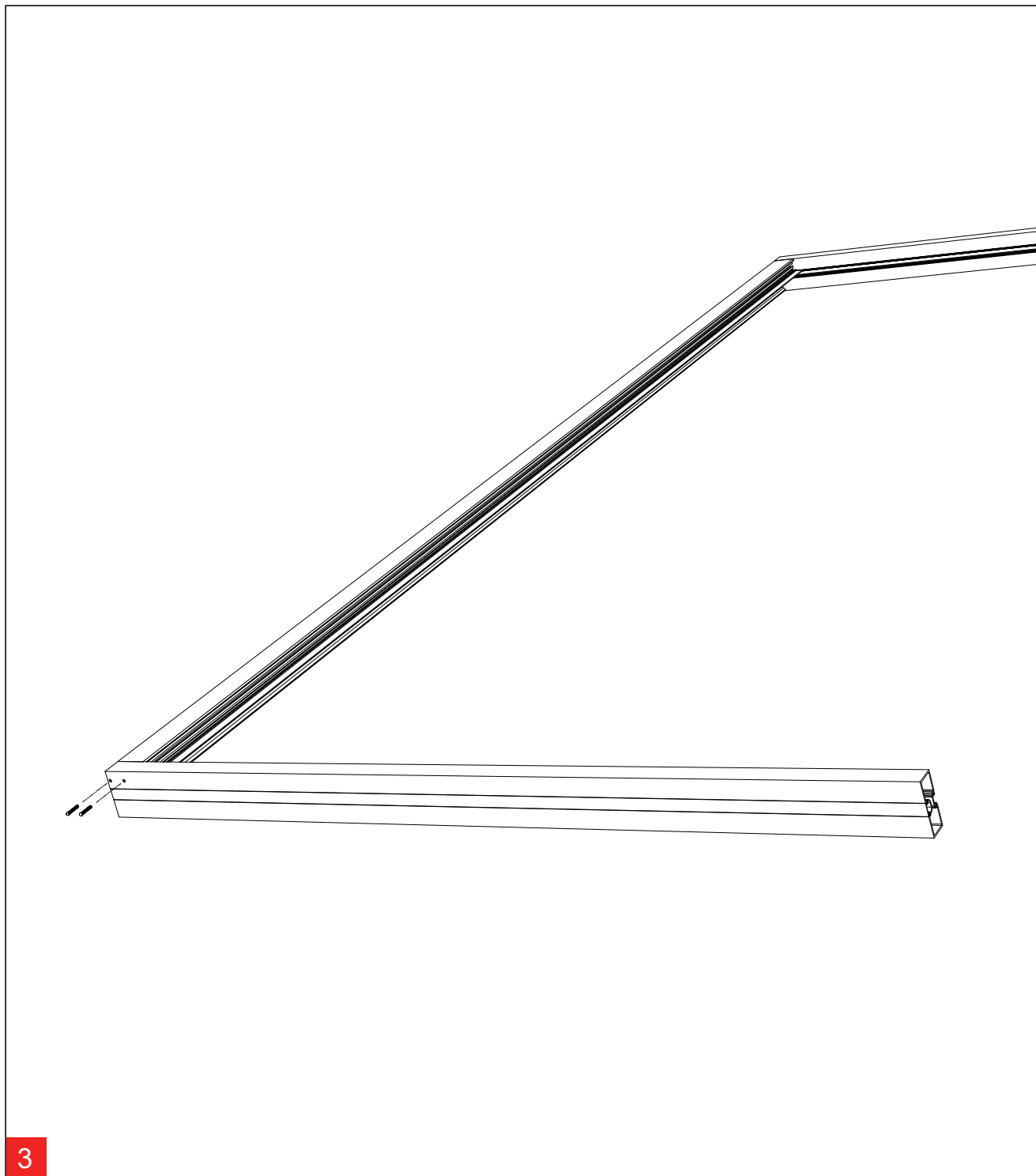

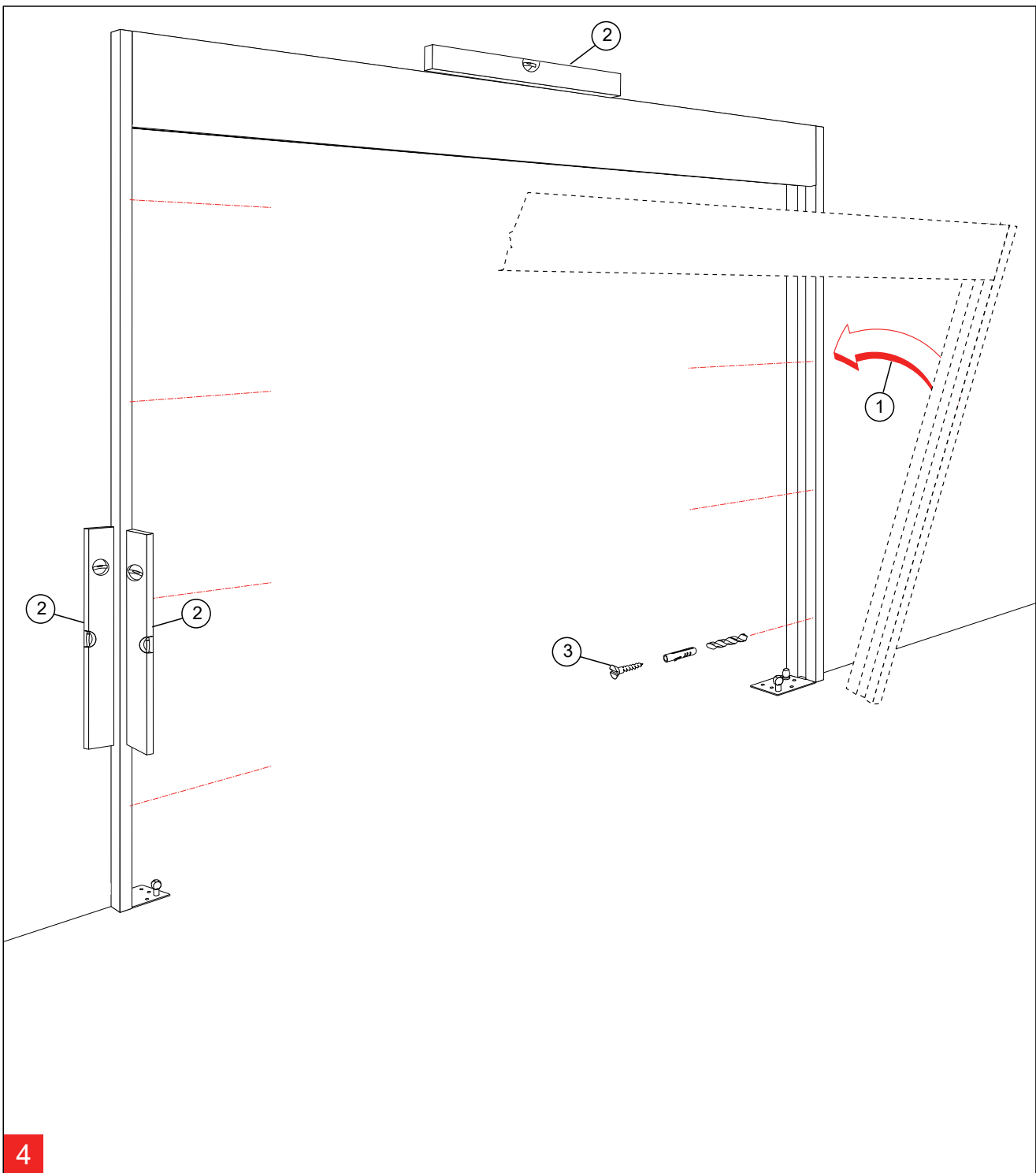

Header to Jamb Assembly

Fasten the header unit to the jambs using (4) #10 x 1" phillips pan heads (2 per side). #2 Phillips screw driver required.



Assembly

- ① Place the header & jamb assembly into the rough opening.  The mounting of the unit to the rough opening must meet applicable building codes and standards.
- ② Level all sides and shim as required.
- ③ Fasten assembly into rough opening, after verifying unit is level and plumb in all directions.
- ④ Place Base Bearing Plate in position.

 Find highest floor elevation and shim accordingly.

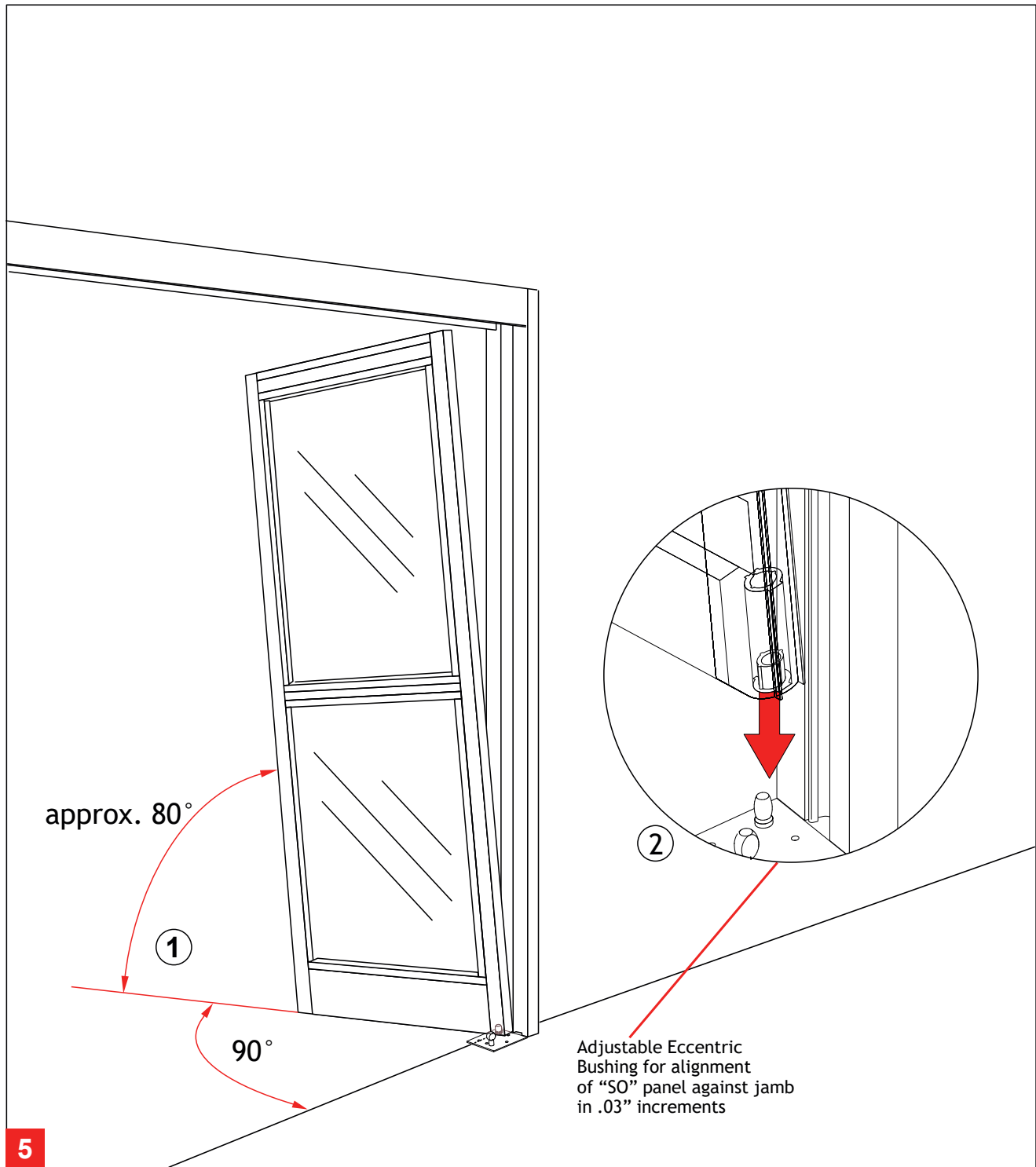

Sidelight mounting

①-② Align "SO" panel 90° to the Base Bearing Plate and 80° to the Vertical Jamb. Place "SO" panel onto bottom pivot mounted on the jamb.

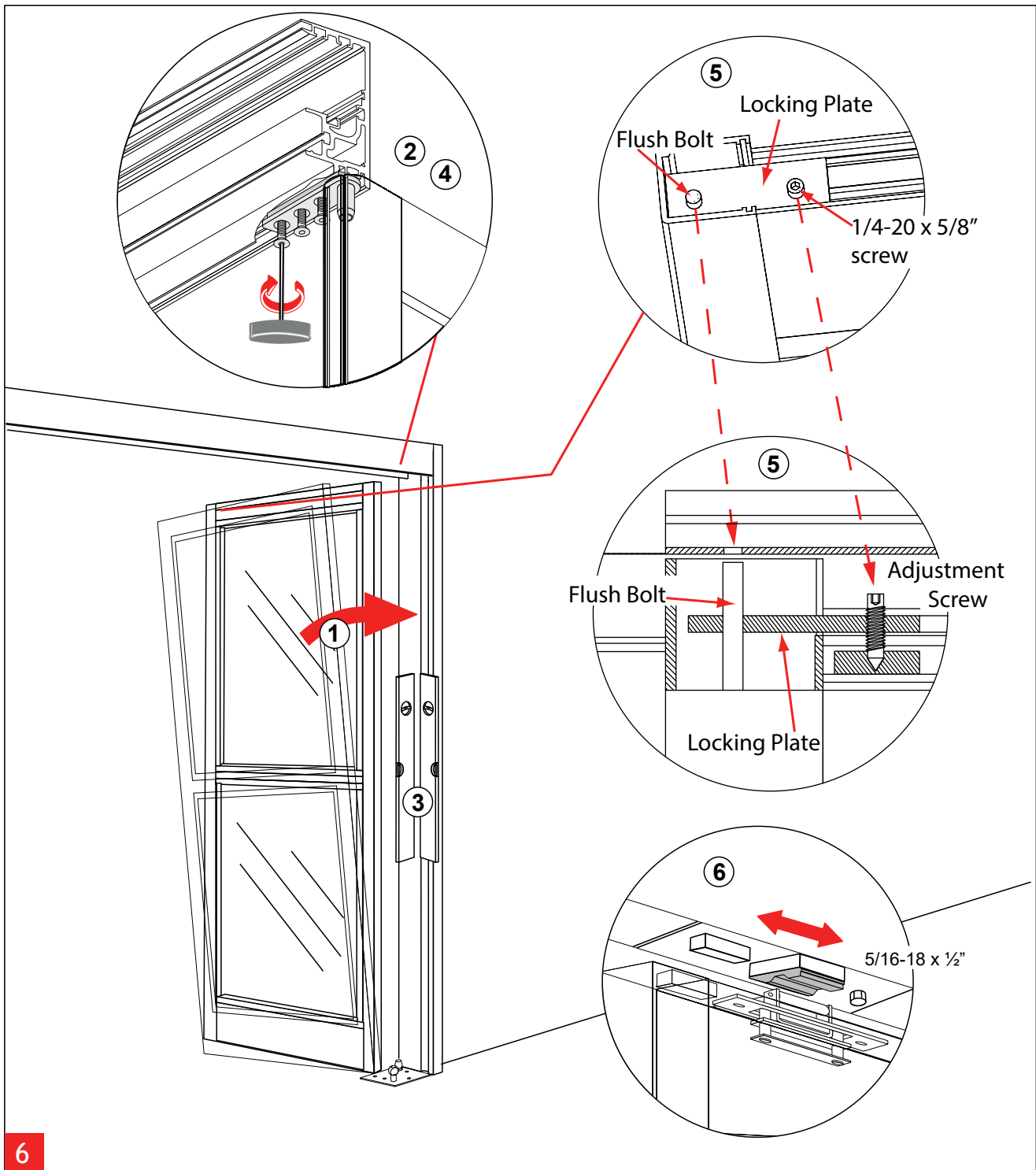

6

Securing the Sidelight

- ①-② Push "SO" Panel vertically to align with jamb. Rotate upper "SO" arm and lightly fasten to screw plate located in header.
- ③ Align and plumb "SO" Panel.
- ④ Tighten (3) 1/4-20 x 5/8 fasteners in "SO" top pivot, securing "SO" Panel to header using 5/32" Allen wrench.
- ⑤ Loosen 1/4-20 x 5/8 socket head screw. Adjust locking plate with flush bolt to align with anchoring hole in header. After tightening screw, close sidelite and test flush bolt for proper operation. (1/8" Allen required)
- ⑥ Loosen fastener. Close "SO" panel and align "SO" magnet/latch sub-assembly. Tighten fastener using 1/2" socket/wrench. For roller catch tension adjustment, see Page 14.

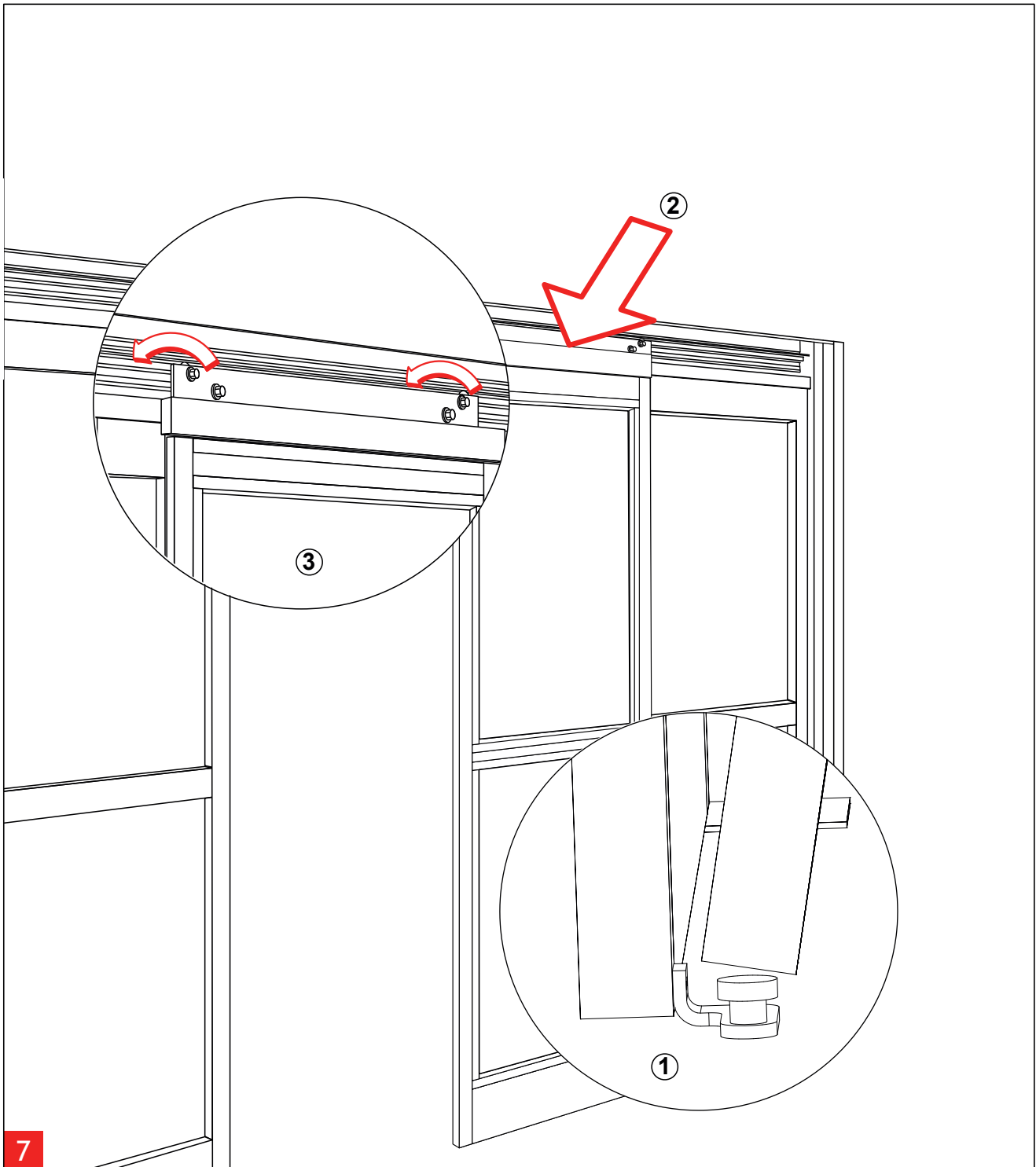

Hanging the "SX" or "SX2" panel

- ① Lift "SX" or "SX2" panel over Bottom guide assembly located on bottom of "SO" panel.
- ② Place "SX" or "SX2" panel rollers onto outer roller track by lifting panel in place.
- ③ Adjust "SX" panel per page 11.

 When installing a telescopic unit, you must adjust door height completely before proceeding to next step

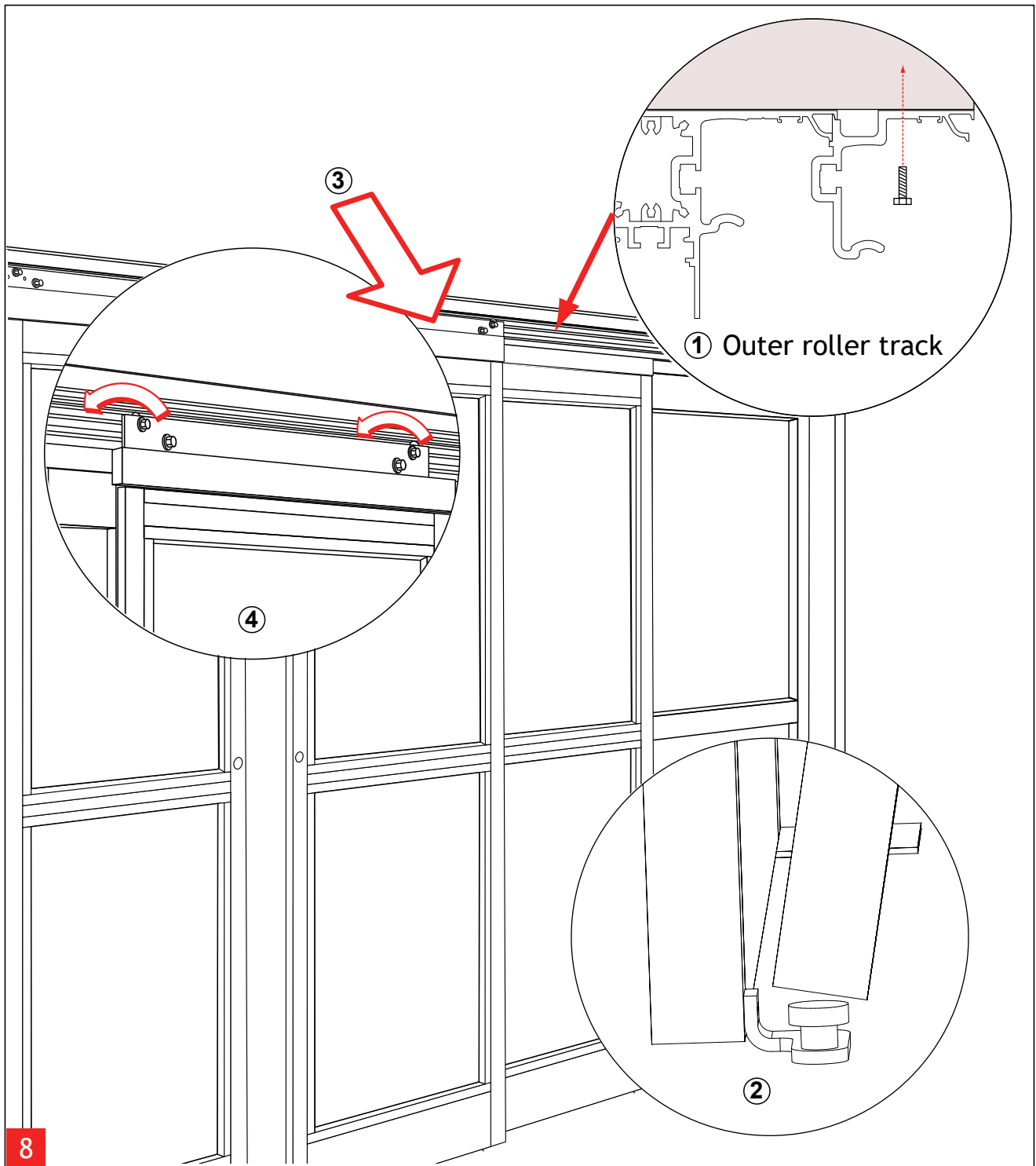

Hanging the “SX1” panel for telescopic 3 leaf and 6 leaf units

- ① Install outer roller track by fastening into masonry opening.
- ② Lift “SX1” panel over bottom guide assembly located on bottom of “SX2” panel.
- ③ Place “SX1” panel rollers onto outer roller track by lifting “SX1” panel in place.
- ④ Adjust “SX1” panel per Page 11.

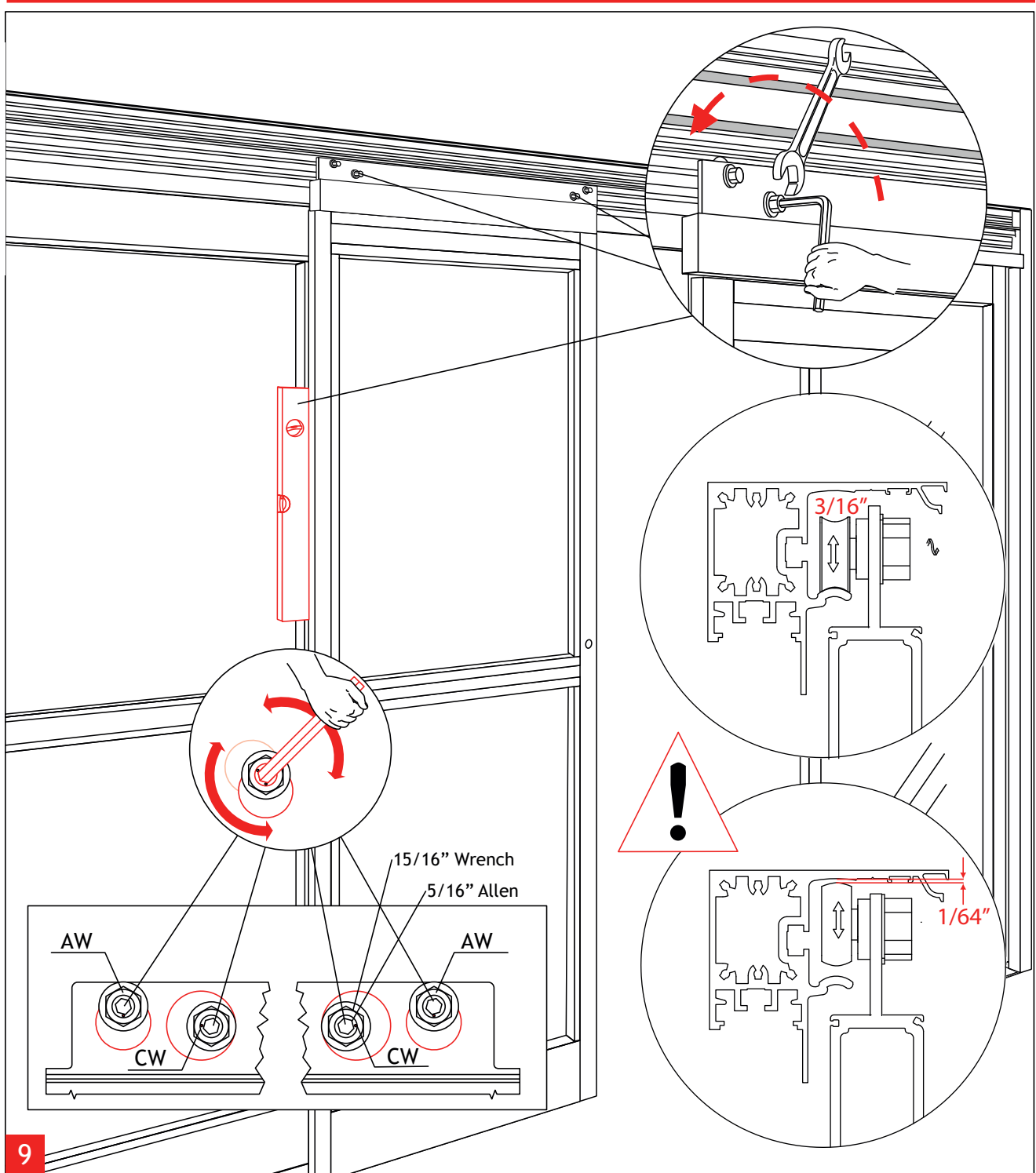

9 Vertical Alignment for “SX1” and “SX2” panels

Using the eccentric carrier wheel (CW), and the anti-riser wheel (AW), level the sliding panel. Tighten hex nuts to secure the adjustment.

! Adjustment of the anti-riser roller:
The anti-riser roller should not contact the top track anywhere along the slide path of the door.

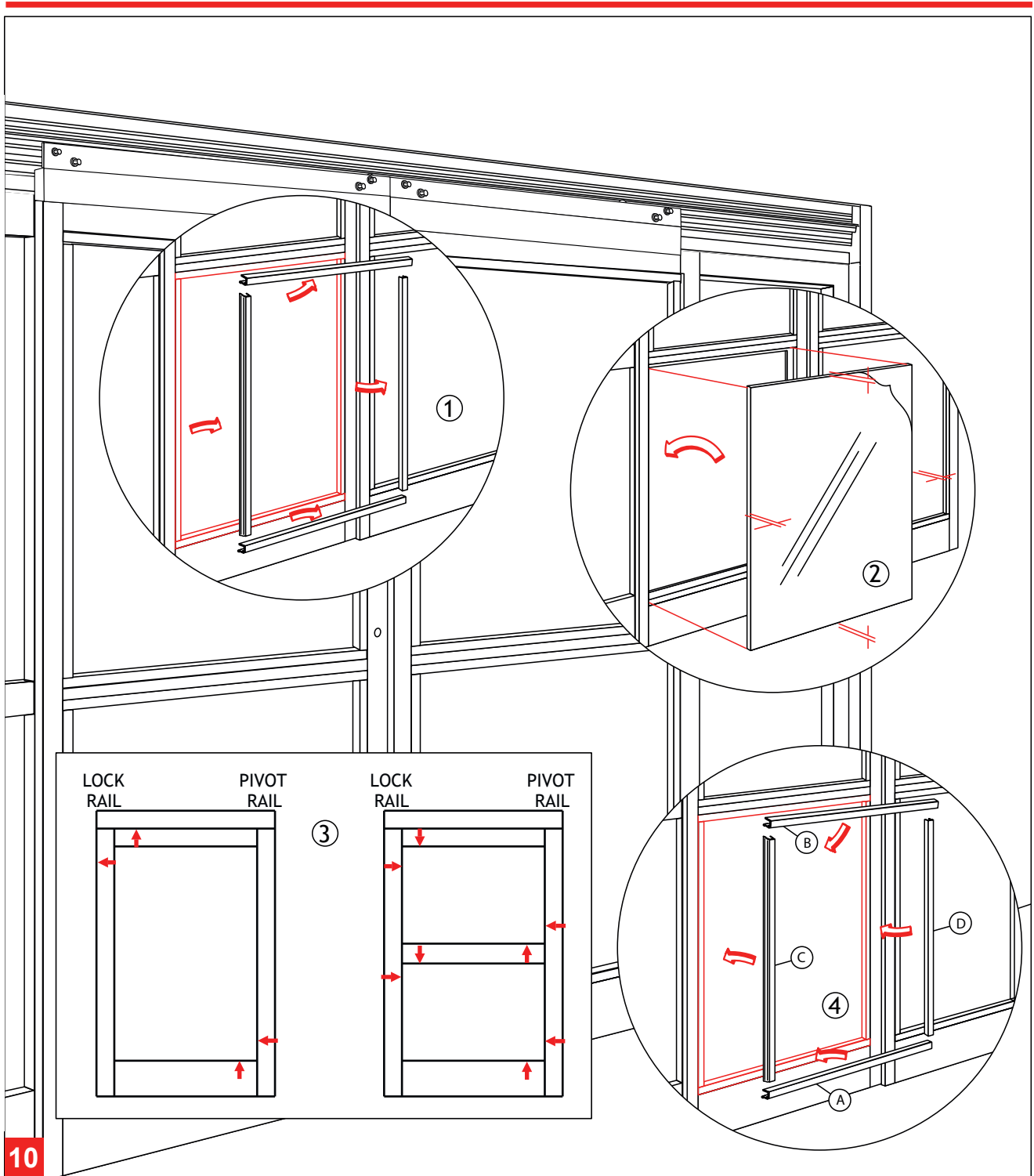

Glazing

- ① Remove the glass stops from exterior side (4 per opening).
- ② Center the glass in opening.
- ③ Properly block and/or cushion glass edges.
- ④ Press the glass stops into place starting with the horizontal stops, then follow with the vertical stops.

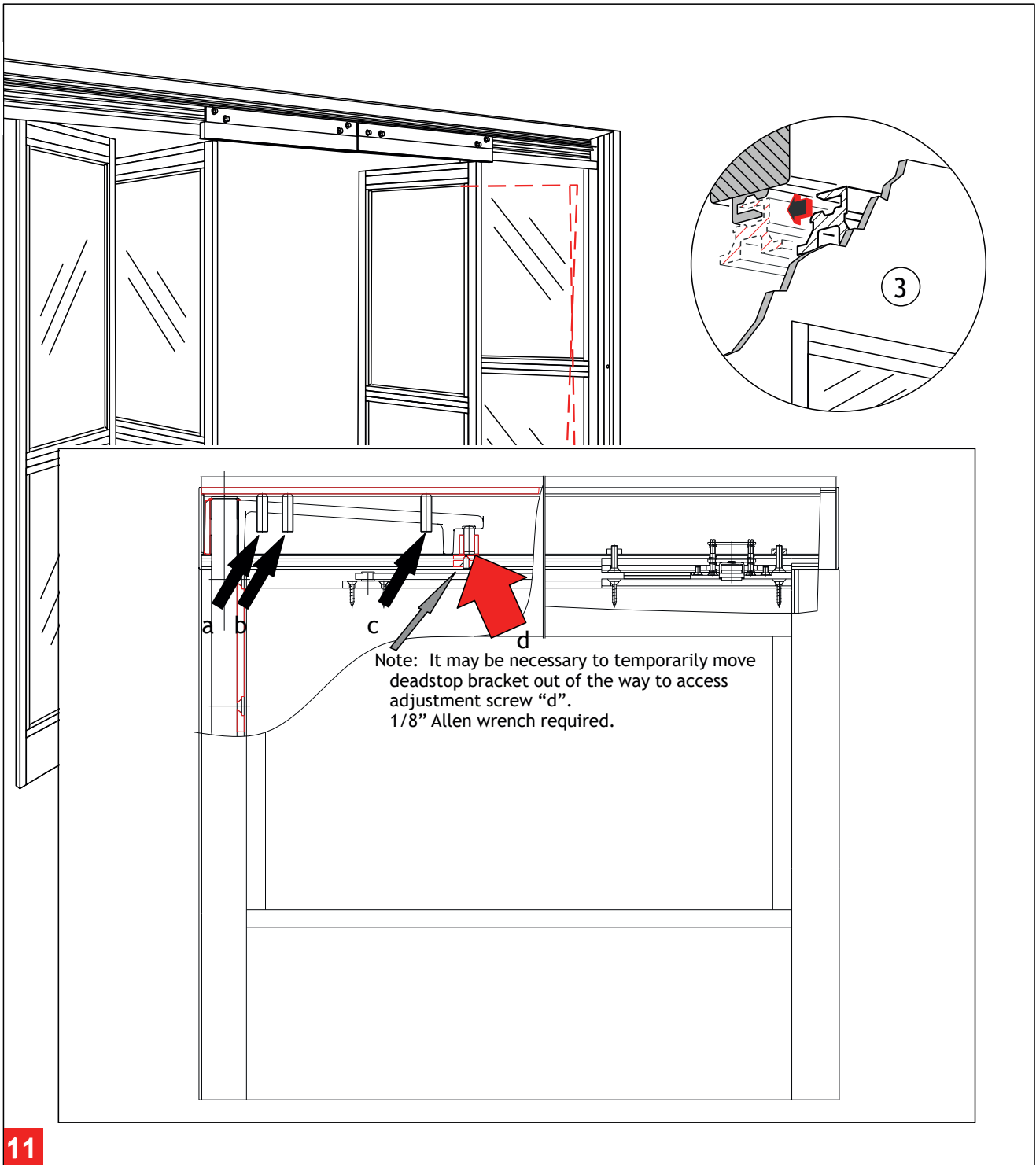

11

Adjustment of the Breakout-Unit

1. Loosen the set screws (a, b & c) to prevent interference while adjusting door. (7/32" Allen wrench required.)
 2. Use the adjustment screw (d) to lift (CW), or lower (CCW), the leading edge of door.
 3. Continue adjustment until the re-latch profiles are properly aligned.
 4. Tighten all set screws (a, b & c) until tight and secure.
- Recheck the latched position alignment and readjust as necessary.

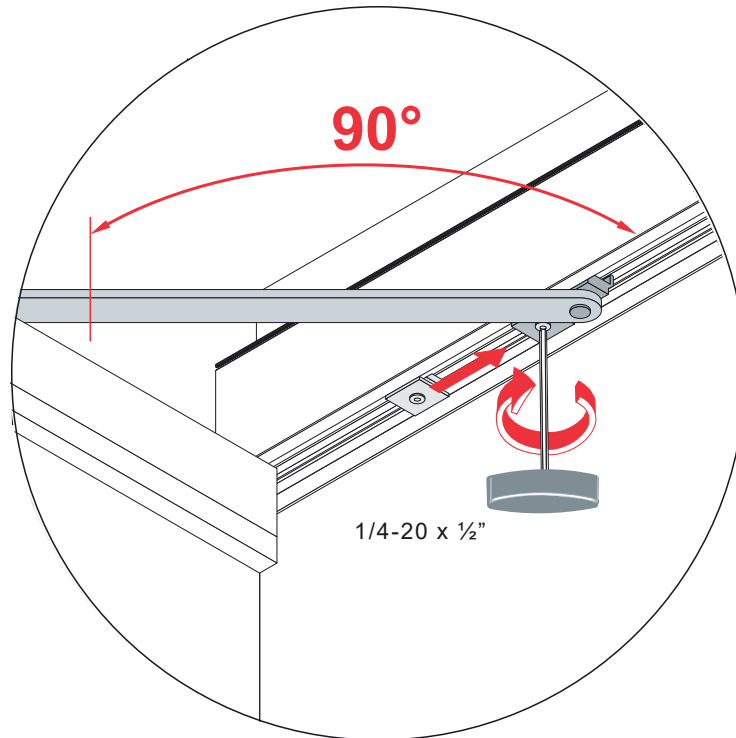

12

“SO” Panel Breakout Adjustment

1. Open “SX” & “SO” panels to 90°.
2. Move arm stop blocks to engage arm. (1/8” Allen wrench required.)
3. Secure stop blocks.

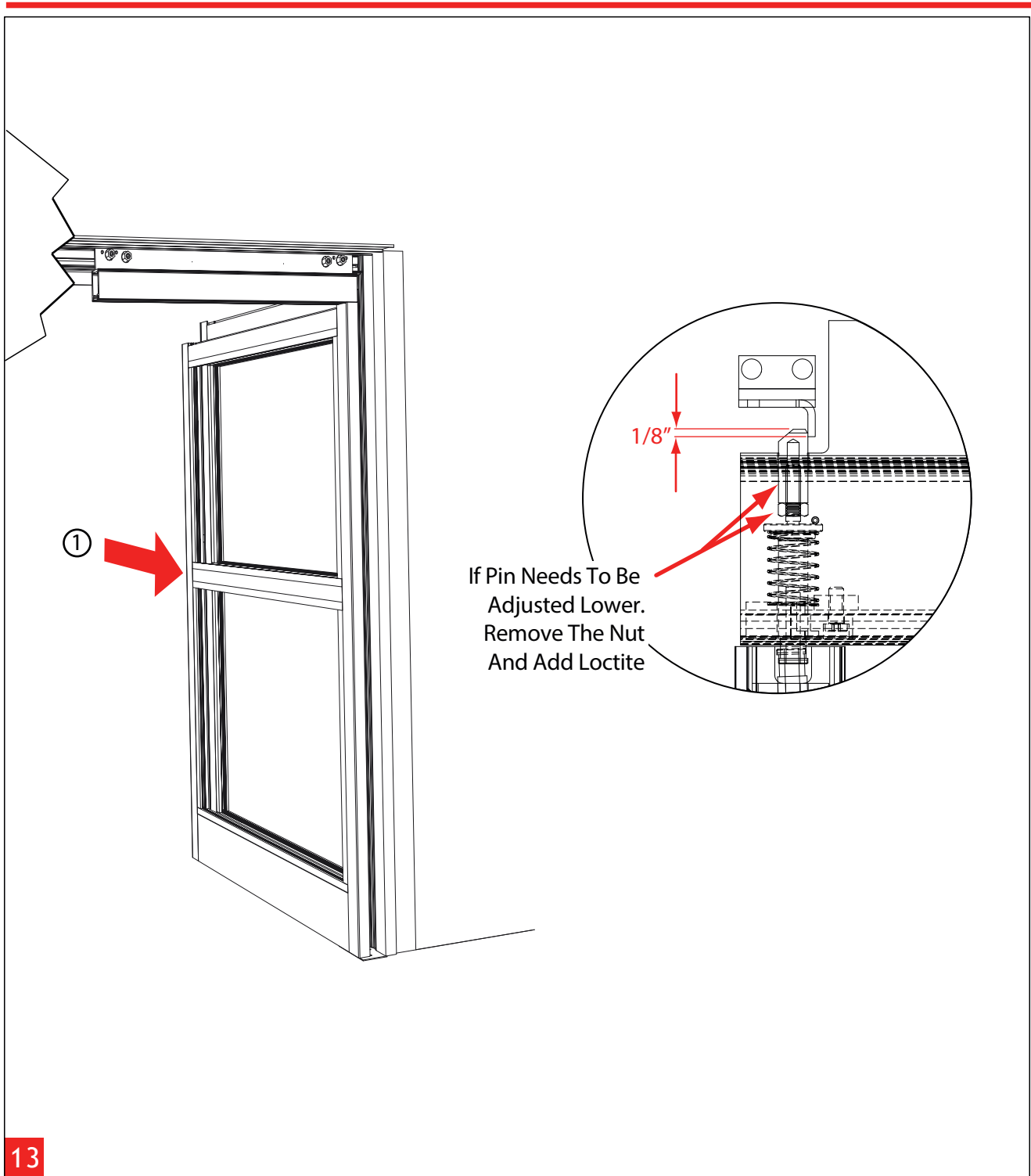

13

Positive Latch Pull and Latch Pin Adjustment

1. Remove astragal on side of door.
2. Adjust pin to provide 1/8" (3.2mm) of Latch Pin Engagement.
3. Test door for proper Latch operation and Breakout function.

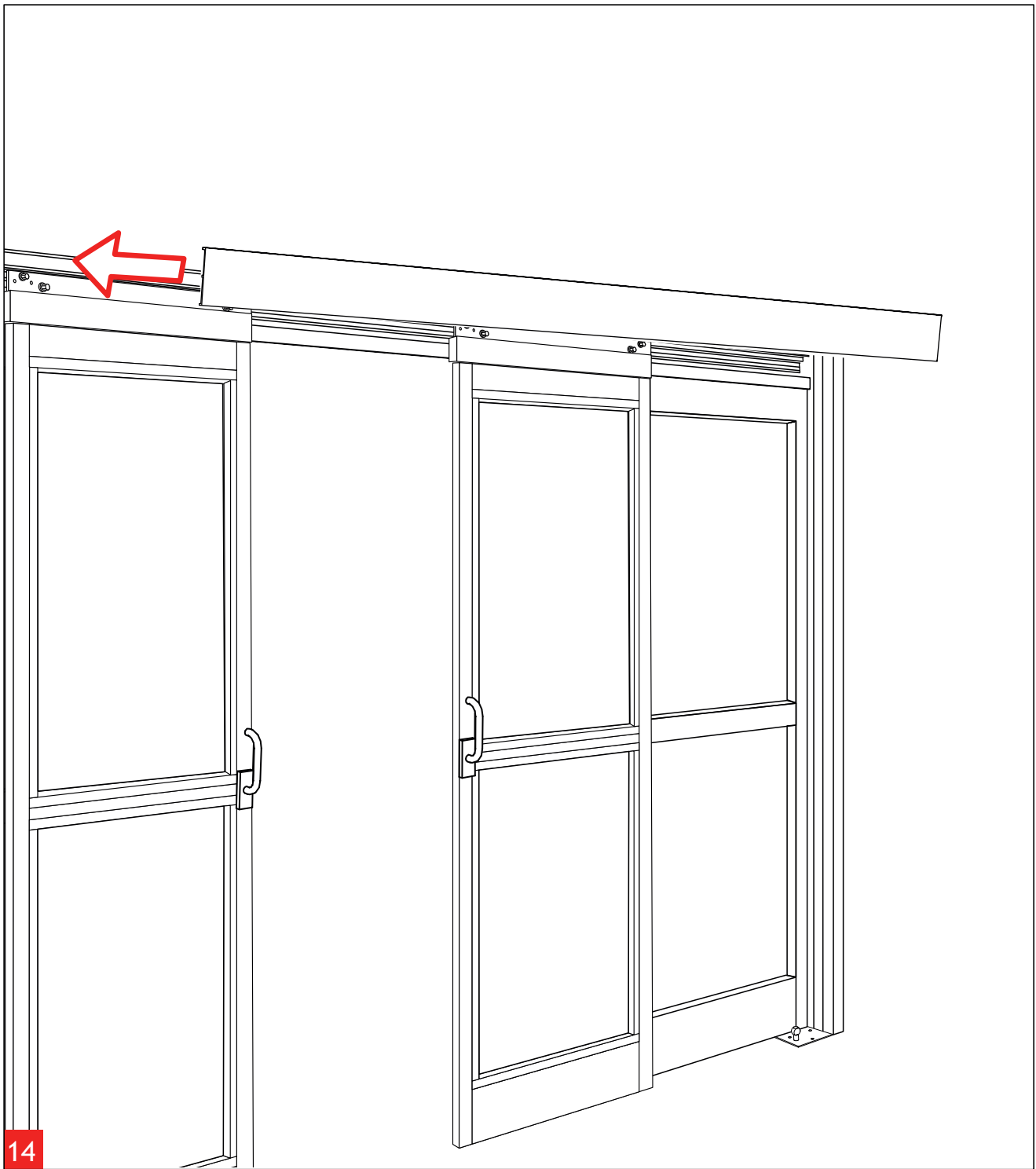

14 Install Closeout Cover

Attach Closeout Cover using 1/4" - 20 screws, one on either end.

 Ensure proper operation of door before installing Closeout Cover. If door is latched shut without proper Positive Latch adjustment, door will not open and Closeout Cover will be difficult to remove.

This page left intentionally blank.

