

Saffire LX™

Electronic hotel lock



Saffire LX

The Saffire LX electronic hotel lock features sophisticated RFID technology in a contemporary, understated design.

Its high performance represents a secure, flexible solution bringing online capabilities and convenience to satisfy the technology needs of hotel properties, while optimizing the guest experience.

Mobile Access

Saffire LX is offered as a Bluetooth® Low Energy enabled lock that is combined with Ambiance MX, to make mobile access a reality - simply and securely. Convenient, reliable and secure for both the hotel property and guests, Ambiance MX supports dormakaba mobile access solutions utilizing Bluetooth Low Energy (BLE), the preferred communication technology for dormakaba hotel locks. Guests can then conveniently use their mobile device to access their room and common areas in the hotel when doors are equipped with Saffire LX.



Ambiance Access Control Management Software

The Saffire LX is supported by Ambiance, dormakaba's most modern access control software. Ambiance is the most flexible and scalable access control solution, developed to power your dormakaba electronic hotel locks and control access throughout your property. Ambiance meets the customer experience expectations by focusing on qualities that enhance the hotel daily operations: value, connectivity, mobility, security, scalability and overall user experience.



Ambiance RX

Ambiance RX remote lock management provides the ultimate guest experience in security and management while maximizing hotel staff efficiency. When paired with Saffire LX or any dormakaba online RFID hotel lock, Ambiance allows staff to monitor door activity through a series of notifications regarding events that occur to the lock.

Ambiance MX

Ambiance MX supports dormakaba Mobile Access Solutions utilizing our Bluetooth Low Energy (BLE) lock selection.

Ambiance PX

Ambiance PX integrates with dormakaba's Keyscan Aurora to provide the ultimate in perimeter access control management. The solution is ideal for hotels of any size – mixed residential and hospitality requiring centralized control with the flexibility of segmented use to accommodate guests, tenants, staff, visitors and workers.

Saffire LX is the innovative solution that combines smart security with aesthetics to harmonize with progressive hotel technology and amenities.

Applications

Saffire LX is designed for your guestrooms, common areas and back-of-house access control. It is suitable for small to very large-scale properties, making it an ideal solution for your new construction and renovation projects or when you are replacing doors. The installation process is eased thanks to a simplified door preparation.

Low Maintenance

Easy to use and requiring minimal maintenance, Saffire LX operates with a completely sealed contactless reader.

In addition, the three AA batteries last up to two years or up to 80,000 openings. When the batteries are running low, the lock indicator alerts staff that they need to be changed soon.

The Saffire LX programming and audit records are not erased during battery replacement.

Security Features

Saffire LX provides security, efficiency and convenience to create a positive guest experience:

- Access tracking: the lock writes information on staff RFID keycard for enhanced staff monitoring
- Saffire LX is offered with mechanical or electronic override for emergency access
- Saffire LX is optionally equipped with a tracking mortise allowing hotel staff to receive door ajar reporting

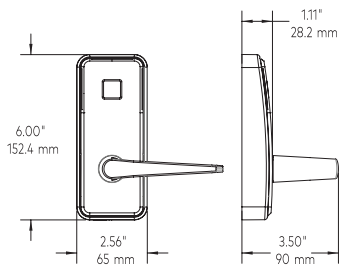

Electronic Key Override

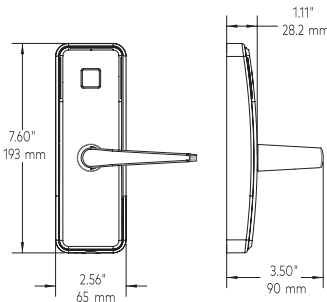

Mechanical Key Override

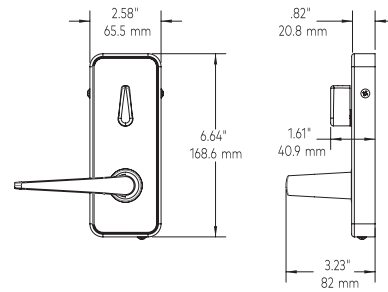

Inside



Mechanical features

Description	Heavy duty electronic lockset (mortise or cylindrical) with clutch mechanism and built-in contactless RFID reader
Handing	Left or right factory handed mortise, field reversible handing (lever and mortise)
Lever	Von, Troy, DIN* and Essen levers (field reversible) *DIN only available in Europe
Finishes	Satin chrome, satin brass, satin nickel, bright chrome, oil-rubbed bronze, and black. Exterior options available for satin chrome, satin brass, satin nickel and bright chrome only. Oceanfront exterior finish available in satin chrome only. Polycarbonate finish: black
Door thickness	From 1 3/8" to 2 1/2" (35 - 66mm)
Standard backset	ASM: 2 3/4" (70mm), Cylindrical unit: 2 3/8" - 2 3/4" (60 - 70mm), Europe: 55 - 80mm
Locking options	ANSI lock case with 1 1/4" (31.75mm) or 1" (25.4mm) lock front mortise Cylindrical latch European DIN mortise lock case Optional automatic deadbolt - not for European lock case
Batteries	3 AA for 2 years or up to 80,000 openings. Low battery indicator alerts staff that batteries need to be changed soon
Concealed key override	KIK core (keyed-alike, master key, recodable).
Remote lock management	Ambiance RX allows hotel staff to monitor door activity through a series of notifications.

Mobile access

Bluetooth® Low Energy	Bluetooth® Low Energy (BLE) integrated. Ready to operate using dormakaba mobile access solutions
-----------------------	--

Lock operation

Date/time stamp	Real time: date and hours/minutes
Programming & audit trail downloading	Hand held programmer and lock utilize Near Field Communications (NFC)
Preregistered keycards	Up to 10 days in advance
Keycard expiry	From 1 to 7 years, depending on system configuration
Passage mode	Set by authorized keycard
Lockout mode	Set by authorized keycard
Credentials	Supports MIFARE Ultralight® C , MIFARE Plus®* EV2 and MIFARE® DESFire® EV3 credentials *MIFARE Plus EV2: When used in enhanced security mode available in Ambiance v2.10+ Available in keycards, key fobs, and wristbands
Feedback	LED light indicators
Diagnostics	Light indicators and handheld display
Audit memory	up to 4000 events
Privacy override	Default emergency keycard only (user selectable)

Certification & testing

Accessibility standard	Complies with 2010 ADA Standards for Accessible Design – Art. 309.4 (Operable Parts). For models with long lever only. Lock shall be properly aligned with the mortise or latch and must be installed strictly according to the dormakaba installation instructions and the ADA Standards and Regulations applicable for each facility, to be able to fulfill compliance with ADA requirements.
Fire rating	Meets UL 10C and ULC S-104, on fire door rated up to and including 3 hours with dormakaba ANSI mortise lock case and cylindrical lock.
North America standards	Florida Building Code: Certification for windstorm and HVHZ & non HVHZ (High Velocity Hurricane Zones) for locks equipped with ASM mortise only. Pending tests for: - BHMA/ANSI: Grade One performance tests for "ANSI/BHMA A156.13 "American National Standard for Mortise Locks and Latches," and "ANSI/BHMA A156.25 "American National Standard for Electrified Locking Devices." (Only locks tested and approved by non-biased third-party test lab are allowed in the "BHMA Certified Products Directory" found at www.buildershardware.com)
Europe standards	- EN1634-1 Fire resistance test for door and shutter assemblies and openable windows: Listed for 30 minutes with ANSI mortise lock case and European mortise lock case - EN12209 Mechanically operated locks, latches and locking plates: ANSI mortise lock case and DIN mortise lock case - EN 179 with European mortise lock case and approved levers. - German Abz certification # Z-6.100-2592 with 9 mm spindle
Electronics	Compliant with CE 61000-4-3 and CE 61000-4-4 for electromagnetic compatibility and FCC part 15 requirements.
Environmental operating conditions	-31°F to +158°F (-35°C to +70°C) 0% to 90% non-condensing humidity at 86°F (30°C) IP54 certified

Warranty

Standard warranty	Two years
Extended warranty	dormakaba service plans available

Any questions? We would be happy to advise you.

Contact us at: 1.800.999.6213