

# INSTALLATION



## EML371/EML372

### Electromagnetic Locks

#### Pre-Installation Instructions

1. This product must be installed according to all applicable building and life safety codes.
2. Due to the variety of mounting configurations available with this product, a survey and assessment of the physical area in which the product will be installed must be performed.
3. The door frame must be inspected and deemed structurally sound prior to installation of the electromagnetic lock. The structural integrity of the mounting surfaces must be strong enough to meet or exceed the holding force of the product.
4. The product must be protected from potential damage due to intruders or tampering.
5. The product must be installed in a location that will not hinder or create a potential safety hazard to authorized personnel accessing the protected area.
6. Because electromagnetic locks are used in a variety of applications and different door frame configurations, an experienced installer with knowledge of this product must make a determination of the optimal mounting method for this specific application.
7. The components, hardware, installation instructions and mounting template included with this product are intended for use on outswinging doors.

PLEASE DELIVER ALL INSTALLATION INSTRUCTIONS TO THE END-USER UPON COMPLETION OF THE INSTALLATION.

8. Do not install this product on the exterior of buildings.
9. Do not use as a doorstep. This will void warranty.
10. Separate accessories not included with this product must be used in the following applications:
  - Inswinging doors
  - Narrow head jamb situations or center-hung doors
  - Wherever there is insufficient space on the door frame header to mount the lock
  - Glass or Herculite doors that do not have a door frame
  - Hollow metal or wood frames where the door stop is not thick enough to allow the product to be installed
  - Wherever an obstruction in the door prevents installation of the armature plate at a proper height
  - Doors that do not permit the armature plate to be mounted low enough to meet the magnet surface

Refer to the Product Accessories Guide section of the Installation Instructions for further information. Accessories may impact holding force.

11. Installation of this product should be done by an experienced installer with knowledge of this product.

**NOTE:** It is highly recommended that thread locking compound be applied to all screws during installation to reduce chance of screws loosening over extended time.

#### Instructions

1. Mount the electromagnetic lock to the door frame as outlined on the installation template included with the product.

**NOTE:** During installation of the armature plate to the door it is essential that the armature plate remains movable. The armature plate must be allowed to pivot on the center-mounting bolt to allow proper alignment with the magnet surface. If the plate is not aligned with the magnet surface, the lock may lose holding force or not lock at all.

The head of the armature mounting bolt ships with a rubber washer affixed to it. This washer should project slightly beyond the surface of the armature plate. This is to allow the washer to expand when power is removed and break the air vacuum between the plate and the magnet surface. If this washer is removed or trimmed the lock will appear to have some holding force even when power is removed.

For added safety, thread locking compound has been provided for the armature plate bolt and the four captive electromagnetic lock mounting screws.

**WARNING: Improper installation, maintenance, inspection or usage of the product or any related accessories or parts may cause the electromagnetic lock, armature plate and associated hardware to disengage and fall, causing serious bodily injury and property damage. DORMA will not be liable to the installer, purchaser, end user or anyone else for damage or injury to person or property due to improper installation, care, storage, handling, maintenance, inspection, abuse, misuse or act of God or nature involving this product or any related accessories or parts.**

2. Route the power supply wire through door frame and into magnet housing. Connecting wire should be of sufficient gauge for the lock being installed and the distance being run. See table for current draw specifications and wire gauge chart.

# EML371/EML372 Electromagnetic Lock Installation Instructions (Continued)

**Figure 1. Wiring : For Unmonitored or DP Sensor Models**

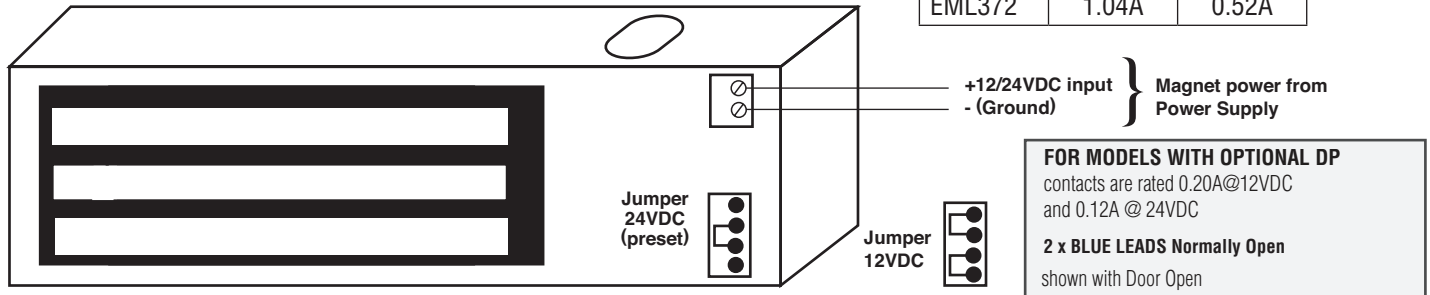

## BOND ALERT (BA) with LED

This feature can detect the quality of the locking bond between the surface of the magnet and the armature plate. The sensitivity of this feature is such that a foreign object with a thickness of .007" (.18mm) is sufficient to allow the sensor to detect a problem.

Due to the sensitivity of this feature and the necessity to maintain a reliable locking bond, these surfaces must be kept free of contaminating materials. Both the lock surface and the armature plate must be cleaned periodically with a non-abrasive cleanser. Alignment of armature plate and magnet is required to ensure proper function of sensor.

Green LED indicates door locked with secure bond.  
 Red LED indicates door unlocked or poor bond.

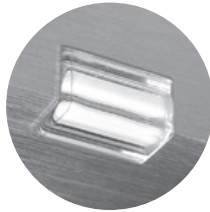

## DOOR POSITION SWITCH (DP)

The DP option monitors the position of the door upon which the lock is installed. A SPST reed switch eliminates the need for extra sensors to be installed on the door for notification of security or access control systems. The DP option comes with a magnet pre-installed into the lock armature plate for signaling the reed switch in the housing when the door is closed. Care should be taken during the final testing of the lock to ensure that the DP option is operating in the desired manner.

**Figure 2. Wiring : For BA or BA DP Combination Models**

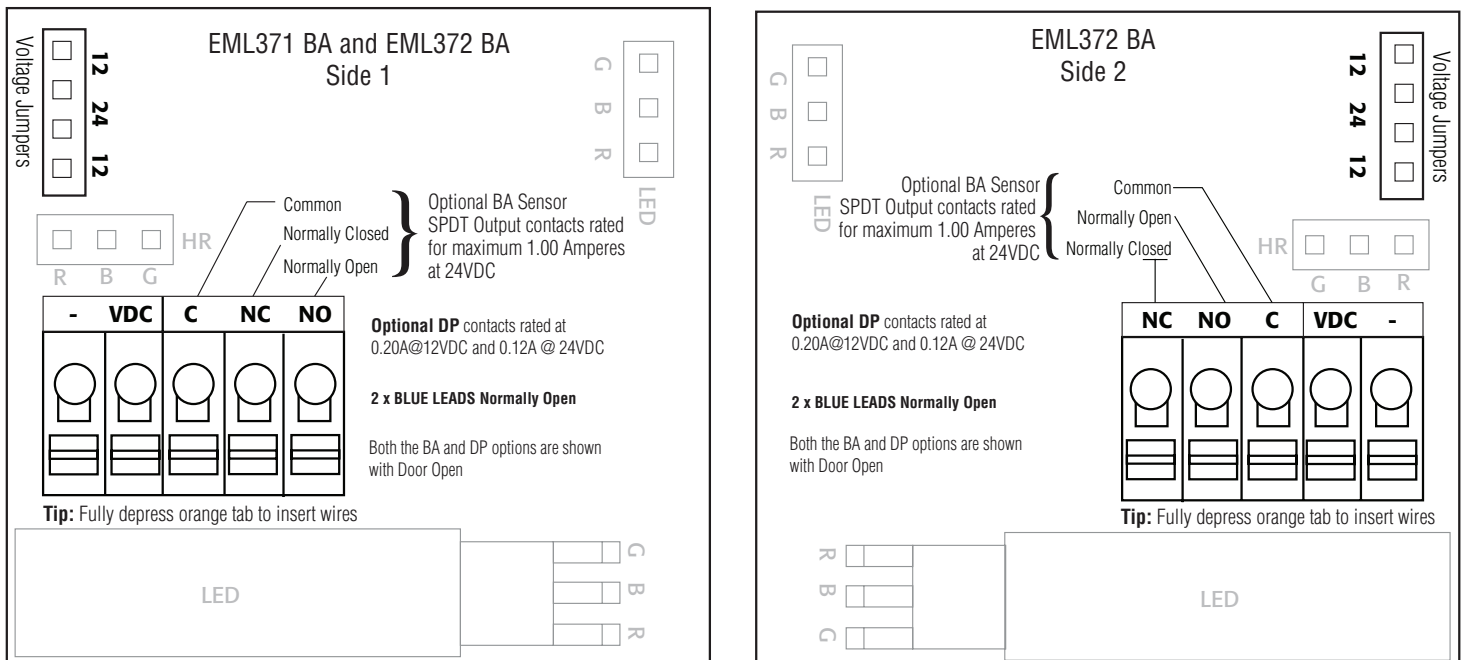

# EML371/EML372 Electromagnetic Lock Installation Instructions (Continued)

## Power Connections

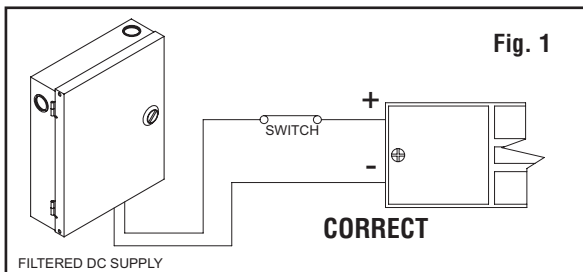

**NOTE:** All DORMA electromagnetic locks must be powered with filtered and regulated DC power supplies such as the DORMA PS Series UL Listed power supply. DORMA offers a full line of power supplies and switching devices that are suitable for use with the EML371 and EML372 Surface Electromagnetic Locks.

**To Ensure Instant Release** All switching devices must be wired in between the DC power source and the positive terminal of the lock as shown.

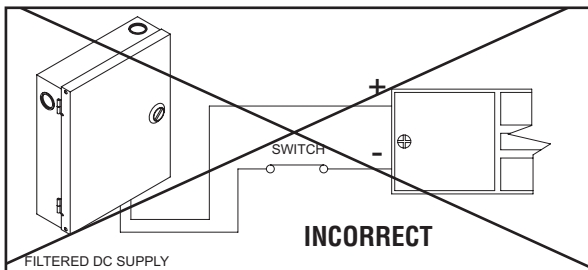

Switching the negative power supply line will not allow the lock to release immediately. DORMA electromagnetic locks contain MOV's for surge suppression and do not require any additional suppression to be added during installation. The installation of diodes across the lock input terminals will cause a delay in release.

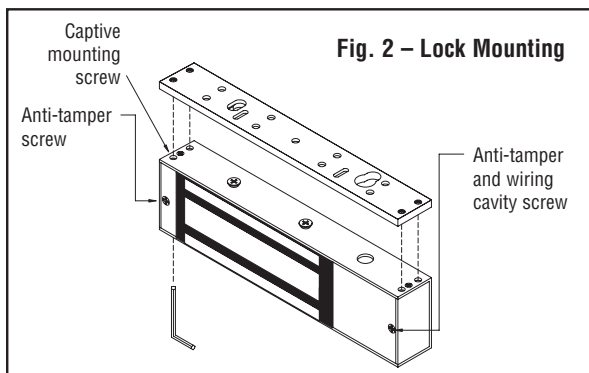

**Anti-Tamper Feature** - Two screws prevent insertion of an Allen wrench into the captive mounting screw opening on the bottom of the lock. Fig. 2 shows their location. One screw also secures the wiring cavity cover. The mounting plate cannot be separated from the lock without removing these two screws. There is an additional anti-tamper screw under the wiring cavity cover. See Fig. 3.

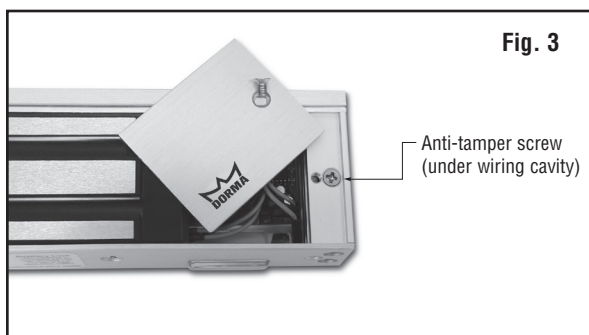

## Specifications

**Mechanical:** including 3/16" [4.8mm] mounting bracket:

EML371 Lock Dimensions:

1"D x 1-7/8"W x 9-3/8"L (25.4 x 47.6 x 238.1mm)

EML372 Lock Dimensions:

1"D x 1-7/8"W x 18-3/4"L (25.4 x 47.6 x 476.3mm)

Armature Plate Dimensions:

7/16"D x 1-1/2"W x 7-1/4"L (11.1 x 38.1 x 184.2mm)

### Electrical:

Voltage: 12VDC or 24VDC

Current: Max 0.52A at 12VDC (each lock on EML372 model)

Max 0.26A at 24VDC (each lock on EML372 model)

**SCS Output Relay:** SPDT relay. Contacts rated at 1.0A@24VDC

**DSS Reed Switch:** Magnetically actuated SPST switch. Contacts rated for 0.20A @12VDC and 0.12A @ 24VDC

### Environmental:

Not for use in outdoor environments.

Circuit board operating temperature: 14° to 140°F (-10° to 60°C)

**NOTE:** Specifications subject to change without notice.

# EML371/EML372 Electromagnetic Lock Installation Instructions (Continued)

## Product Accessories Guide

Accessories may impact holding force.  
(Separate installation instructions provided with accessories.)

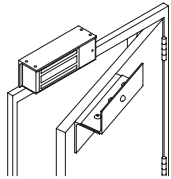
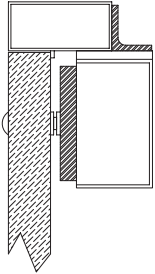
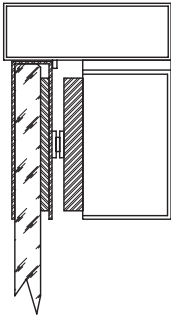
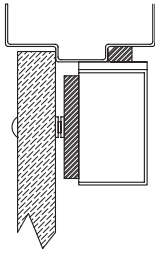
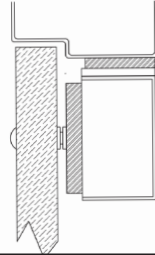
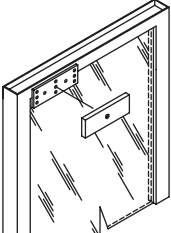
Part	Usage	Example
<p>Top Jamb Bracket (TJ)</p>	<p>Top Jamb bracket and angle bracket kit is required for use when mounting the lock on a door that swings inwards. Magnet mounts to the underside of an angle bracket mounted on the frame. Armature plate mounts to “Z” bracket assembly mounted to door face.</p>	
<p>Angle Bracket (AB)</p>	<p>Used in a narrow head jamb situation or for center-hung doors. Any place where there is insufficient frame depth to mount the lock.</p> <p>Available in several different sizes and finishes. Available for both</p>	
<p>Glass Door Bracket (GDB)</p>	<p>Allows an armature plate to be mounted to a glass or Herculite door that does not have a frame. The Glass Door Bracket is a “U”-shaped piece of 1/16” thick material that slips over the top of the glass panel and tightens to the glass with setscrews. The Armature plate mounts directly to the surface of the bracket by means of a threaded hole in the bracket assembly plate.</p> <p>Available for both 1/2” and 3/4” thick glass doors.</p>	
<p>Filler Bars (FB)</p>	<p>Used to provide extra mounting space in a hollow metal or wood frame where the door stop of the frame is not thick enough to allow a lock to be installed.</p> <p>Available in several different heights and widths.</p>	
<p>Spacer Bars (SB)</p>	<p>For use when an obstruction in the door prevents the installation of the armature plate at a proper height. If the armature plate needs to be lowered then a spacer bar can be used to lower the lock from the frame.</p> <p>Available in several different heights.</p>	
<p>Armature Plate (APH)</p>	<p>For use with doors that do not permit the armature plate to be mounted low enough to meet the magnet surface. Eg: Some aluminum framed commercial glass doors. The armature holder can be mounted to whatever frame is available and the armature plate in turn mounted to the holder.</p> <p>Available in pocket style.</p>	

# EML371/EML372 Electromagnetic Lock Installation Instructions (Continued)

## Troubleshooting Guide

Problem	Solution
Cannot remove the lock mounting bracket from top of magnet for installation.	Remove anti-tamper screw and cavity cover screw. A second anti-tamper screw will be visible after the cavity cover is removed. Insert supplied Allen wrench into mounting bolt holes in the bottom of the lock housing and turn. (See Fig. 2 and 3)
LED goes out when door is locked	Check input polarity.
Lock is installed but has no holding force at all.	Check power supply. DC power should be slightly over the voltage specifications outlined on the packaging. eg: for 12VDC operation supply should be set at 12VDC-13VDC. Check connections at power supply, connected releasing devices, lock terminals and lock circuit board to magnet core.
Lock has enough holding force to lightly hold a screwdriver or set of pliers but door will not lock.	Check to see that armature plate is correctly aligned with the electromagnetic lock. If there is improper alignment, make a 1/4" turn of the armature plate mounting bolt and check for alignment. Make sure to follow the armature plate mounting instructions on the template and Page 1 of this install.
Lock is operating and locking but the armature plate is "humming" against the surface of the lock.	This generally indicates that the lock is either operating on AC voltage or there is some AC voltage present in the DC supply. A properly filtered and regulated DC power supply is required to achieve optimal operation from the lock.
Lock is not releasing immediately upon removal of power	Ensure that switching devices are interrupting the DC power and not the AC power supply voltage. Ensure rubber washer on armature plate mounting bolt has not been removed or damaged  Check that switching device interrupts the positive wire and not the negative wire (See Fig. 1) Remove any Diodes or other suppression devices that may be installed

## Inspection and Maintenance

This product and all related accessories or parts must be inspected and maintained on a **quarterly basis**. Contacting surfaces of the electromagnetic lock and armature plate must be kept free of contaminating materials. Surfaces must be cleaned periodically with a non-abrasive cleaner.

All mounting fasteners must be inspected on a **quarterly basis**. When properly installed, the ends of the armature plate allow a slight movement but the plate will feel secure when grasped at the bolt. There should be no movement to the mounting bracket or housing of the electromagnetic lock.

For added safety, thread locking compound has been provided for the armature plate bolt and the four captive electromagnetic lock mounting screws.

**WARNING: Improper installation, maintenance, inspection or usage of the product or any related accessories or parts may cause the electromagnetic lock, armature plate and associated hardware to disengage and fall, causing serious bodily injury and property damage.**

PLEASE DELIVER ALL INSTALLATION INSTRUCTIONS TO THE END-USER UPON COMPLETION OF THE INSTALLATION.

For product support, parts and ordering information contact:

**For product support, parts and ordering information contact:**

**DORMA**  
**Dorma Drive, Drawer AC**  
**Reamstown, PA 17567 USA**

**Phone: (717) 336-3881**  
**Fax: (717) 336-2106**  
**Toll Free: (800) 523-8483**  
**Email: archdw@dorma-usa.com**

# EML371/EML372 Electromagnetic Lock Installation Instructions (Continued)

## WIRE GAUGE SELECTIONS

Total One Way Length of Wire Run (ft.)	Load Current @24V							
	1/4A	1/2A	3/4A	1A	1-1/4A	1-1/2A	2A	3A
100	20	18	16	16	14	14	12	10
150	20	16	14	14	12	12	10	--
200	18	16	14	12	12	10	10	--
250	18	14	12	12	10	10	--	--
300	16	14	12	10	10	--	--	--
400	16	12	10	10	--	--	--	--
500	14	12	10	--	--	--	--	--
750	12	--	--	--	--	--	--	--
1000	12	--	--	--	--	--	--	--

Total One Way Length of Wire Run (ft.)	Load Current @12V					
	1/4A	1/2A	3/4A	1A	1-1/4A	1-1/2A
100	18	16	14	12	12	10
150	16	14	12	10	10	--
200	16	12	10	10	--	--
250	14	12	10	--	--	--
300	14	10	--	--	--	--
400	12	10	--	--	--	--
500	12	--	--	--	--	--
750	10	--	--	--	--	--

These recommended wire gauge selection tables are based on the 2008 National Electrical Code (2008 NEC), assume 60°C (140°F) rated wire, include a 25% safety factor, and define the amperage ratings at the listed distances that result in 5% voltage drop due to wire resistance. Five percent is normally acceptable in low voltage systems.