

**SECTION 2**  
TYPE: P-SX, SX-P

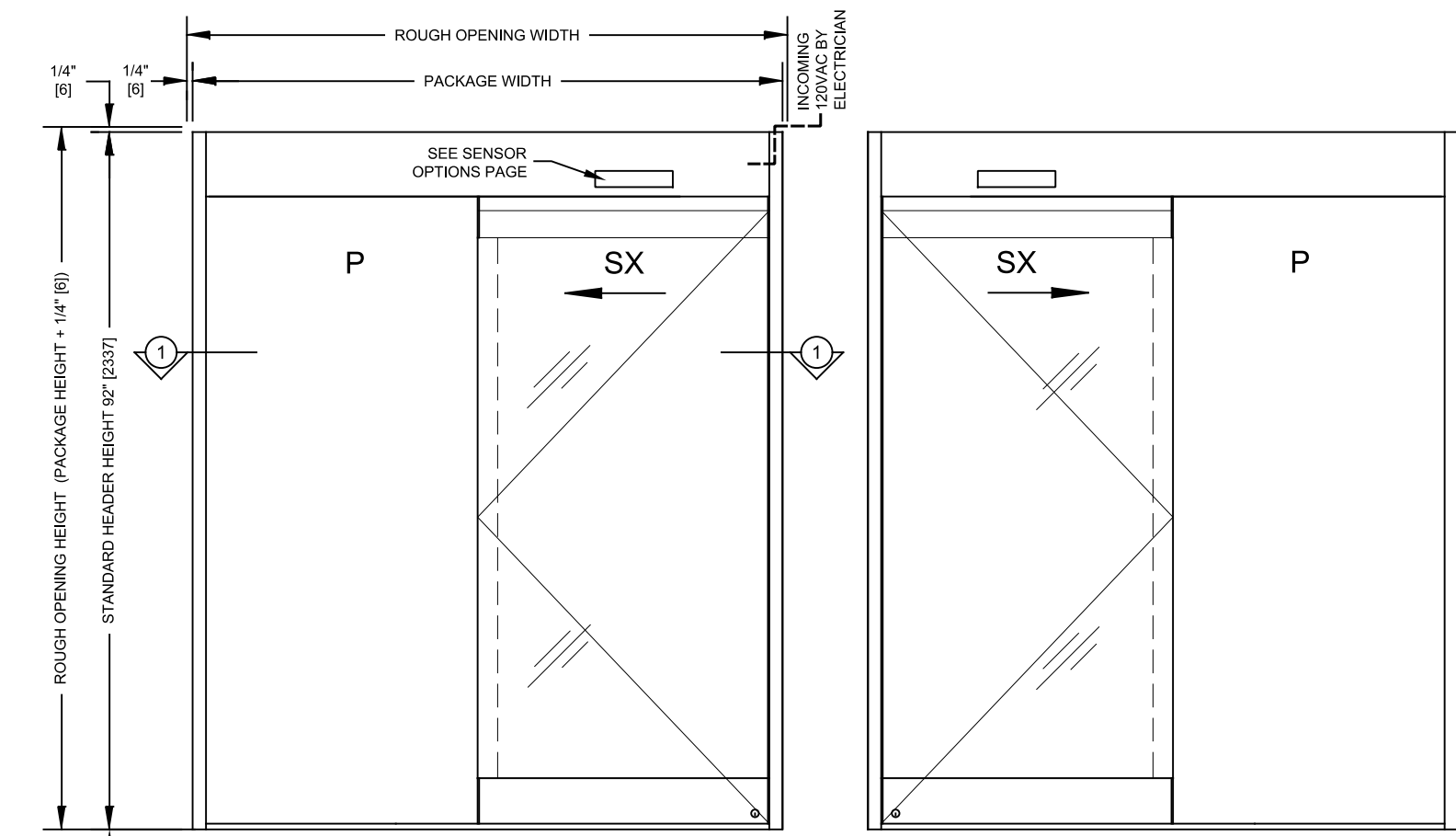

**EXTERIOR ELEVATION**  
TYPE: P-SX, SX-P

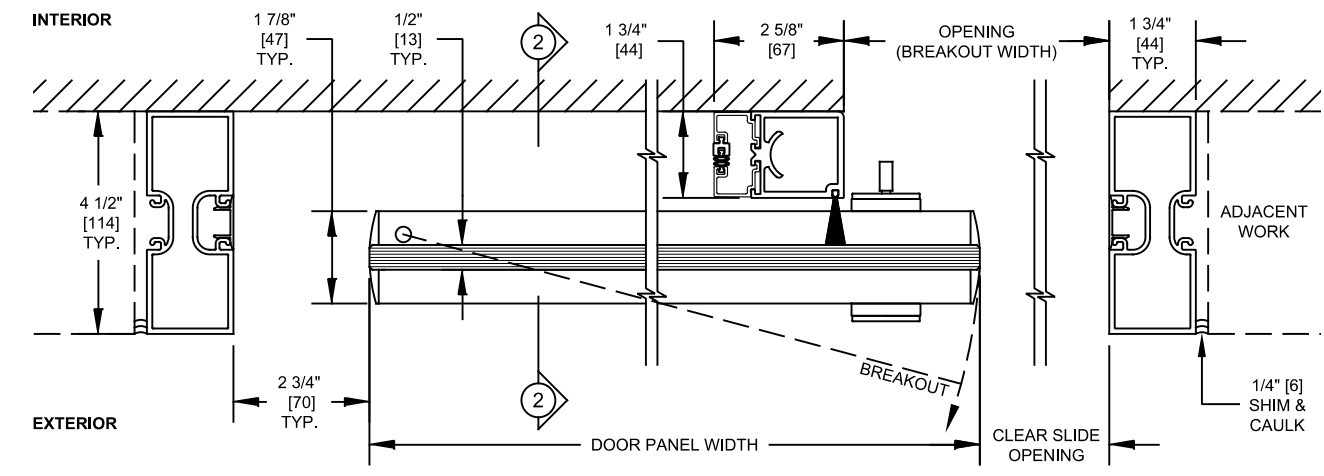

**SECTION 1**  
TYPE: P-SX SHOWN, SX-P OPPOSITE  
DOOR SHOWN IN OPEN POSITION WITHOUT THRESHOLD

Package Width	Rough Opening Width	Clear Slide Opening	Door Panel Width	Breakout Width
(6'-6") 78" [1981]	78 1/2" [1994]	33 1/4" [845]	38 1/2" [977]	36" [914]
(7'-0") 84" [2134]	84 1/2" [2146]	36 1/4" [921]	41 1/2" [1054]	39" [991]
(8'-0") 96" [2438]	96 1/2" [2451]	42 1/4" [1073]	47 1/2" [1207]	45" [1143]
Width Formulas	(Package Width) + 1/2" [13]	(Package Width / 2) - 5 3/4" [146]	(Package Width / 2) - 1/2" [13]	(Package Width / 2) - 3" [76]

- This Standard Surface Applied All Glass Single door package consists of:
  - Operator:
    - Two combination motion/presence sensors (one on each side) (See sensor options page).
    - ESA II motor drive unit with self-learning and self-monitoring microprocessor controller.
    - Jamb mounted 5 function rocker switch panel (see mode switch options page).
  - Panels:
    - 6" [152] Bottom rails.
    - 1 3/4" [44] x 4 1/2" [114] Double Pocket jambs.
    - Vertical and horizontal brush type weather stripping (AAMA-701-11Class A).
    - ADA compliant surface applied track and threshold 1/2" [13] x 4 1/2" [114].
    - Single point bottom rail mounted mortise lock (full threshold required).
    - Breakaway sliding door panels (SX) and vertical pocket tubes (P).
    - 1/2" [13] tempered float glass (not supplied with door).
  - Finishes:
    - Clear anodized (BHMA 204).
    - Dark Bronze anodized (BHMA 313).
- Typical Package Options:
  - Finishes: special anodized, PVDF (wet) paint, powder coat, and cladding available. header, panels and jambs only.
  - Locking and Security Options:
    - Bi-stable Autolock sliding carrier lock concealed in header (only prevents sliding).
  - Jambs: 1 3/4" [44] x 4 1/2" [114] and 2" [51] x 6" [152] smooth available.
- Drawing Notes:
  - Drawing dimensions are in English & Metric units. Metric units are displayed as: 1" [25] millimeters.
  - Package Dimensions (May be limited by panel weight):
    - Each door package is manufactured to your custom size requirements.
    - Package Width: Min. 6'-6" [1981] to Max. 8' [2438].
    - Header Height: Min. 7'-4 1/2" Max. 8' [2438].
    - SX Panel Weight: Max. 225 lbs [102 kg].
  - Maximum special application limits / custom packages: (Sizes may be restricted due to complexity and application). (Please contact dormakaba Architectural Services for dimensions outside of typical sizes above).
    - Package Width: Min. 6'-6" [1981] to Max. 21' [6401].
    - Header Height: Max. 11' [3353].
    - SX Panel Width: Max. Width 48" [1219].
    - SX Panel Size Limit = (SX Panel Width x Weight) < 900 ft-lbs [1220 N-m] Max.
- Power Requirements:
  - 120V +/- 10%, 50/60 Hz, 6.6A peak, 250 W. Up to 4 operators on a single 20A breaker. Service to header by electrician.
- Standards of Compliance:
  - UL 325 & CSA 22.2 (listed with ETL).
  - Designed to comply with these standards depending on installation and application:
    - International Building Code (Section 1008).
    - ANSI/ BHMA 156.10.
    - ANSI/ BHMA 156.38.
    - NFPA 101 Life Safety Code (Section 7.2.1.9).
  - Refer to Local, State, National or AHJ. Building Code for minimum door height and minimum/maximum width allowable for egress requirements.
  - Minimum ADA is 32" clear slide opening.
- Contact dormakaba Architectural Services for more information:
  - Phone: 1-844-SPEC-NOW (1-844-773-2669)