

dormakaba registration unit 90 03

Small and compact



Advantages at a glance

- **Compact design**
Extremely slim dimensions for mounting on door profiles or fittings
- **High security**
High level of security due to encrypted communication with the interior control unit
- **Excellent reading properties**
Surface-mounting, also directly on metal surfaces
- **Future-proof**
Prepared for use with dormakaba Mobile Access

The registration unit is slim and compact and suitable for direct mounting on door frames and any fittings, even on metal surfaces.

Functionality

When combined with the control unit, the registration unit 90 03 provides a fully integrated access control solution and enables easy user identification. The registration unit informs the user acoustically and visually on the access decision.

Secure solution

The registration unit is installed at remote locations away from the reader electronics. The associated control unit can be installed in a tamper-proof room irrespective of the installation site. Communication between the registration unit and the associated control unit is encrypted and, therefore, offers maximum security.

Application field

The registration unit is suitable for both indoor and outdoor applications.

Mounting

- Surface mounting with mounting plate
- Direct mounting on metal also possible
- The connections are established with pluggable screw terminals

Signaling

- Buzzer for acoustic signaling of the access decision
- Illumination unit (red/green) for indication of the operating state and the access decision

Compatibility

The registration unit 90 03 can be used with various dormakaba control devices:

- dormakaba access manager 92 00
- dormakaba access manager 92 30
- dormakaba remote reader 91 15
- dormakaba remote reader 91 25

Note: The product's range of available functions depends on the system context in which it is used.

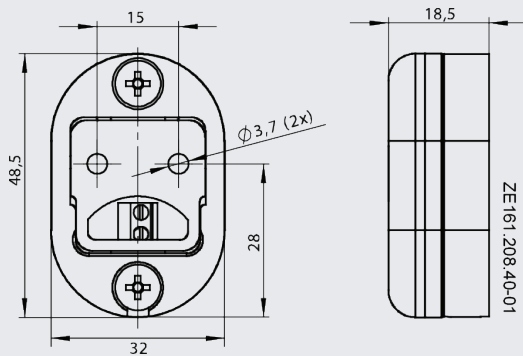

Drawing of the dormakaba registration unit 90 03 (Specification in mm).

Technical specification

Interface

- Communication via a 50Ω coaxial cable, RG 174/U (recommended)

Environmental conditions

- Operating temperature: -25° ... +70°C
- Humidity: 0 % ... 95 %, non-condensing
- Protection class: IP55 (with seal)

Design / material

- Housing and mounting plate:
- PBT VALOX 375 X 7001
- Color: Black

Dimensions

(Length x Width x Height)

- 48.5 x 32 x 18.5 mm

Certificates / standards

- EN 301 489-1, EN 301 489-3,
- EN 300 330-1, EN 300 330-2
- R&TTE 1999/5/EG
- 1999/5/EG

Further details and order information can be found in the relevant dormakaba catalogues or system descriptions.

Subject to change without notice.
© 2023 dormakaba. Version 08/2023

Any questions? We will be happy to assist you.

dormakaba International Holding AG | Hofwisenstrasse 24 | CH-8153 Rümlang | info.de@dormakaba.com | dormakaba.com