

## 1 General



These mounting instructions are the basis for the approval by ECBS, VdS, A2P (CNPP)- DNV, UL. Installation of the lock to be performed exclusively in accordance with these instructions.

Guidelines of the national certification bodies are to be considered and complied with in addition.

- Use high quality alkaline/manganese monobloc batteries only. Low quality batteries may cause oxidation which results in a functional failure of the lock..
- Avoid residual crystalline moisture in the cabinet (e.g. from varnishing) to make sure that electrical contact areas are not attacked.
- Make sure that the ingress of dirt or detergents (e.g. remaining fillers or cold cleaners) is prevented.
- Do not grease/oil the lock or key.
- It is recommended, that unauthorized persons have no access to security sensitive parts of the lock, also the door of the safe, where the lock is installed, is open.

## 2 Mounting instructions for lock and control unit

- **RH version (standard version):**

Lock mounting position	
Bolt LH, keyhole horizontal	
Bolt downwards, keyhole vertical	
Bolt upwards, keyhole vertical	

- **LH version**

Lock mounting position	
Bolt RH, keyhole horizontal	

- Any variation of the lock or key may result in functional trouble and must better not be done. All claims under guarantee and warranty will expire in this case.
- Lock fastening: Use of M6 steel socket head cap screws or BSW ¼" steel bolts. The length of engagement must correspond to the applicable standards considering the thickness of the lock of 30 mm and the screwing height of the lock case of 24 mm.
- Fastening screws: minimum property class 4.8 and maximum property class 8.8.
- Screws to be secured either by lock washer, flat spring, tooth lock washer, fan type lock washer considering the diameter (d1) or to be cemented.
- Screw tightening moment : minimum 5 Nm and maximum 6 Nm.
- The bolt must be floating in installed condition.
- Perfect function of the lock and of any additional connected or triggered systems (e.g. boltworks) must be warranted and checked by specialists during installation of the lock.
- The lock must be mounted in closed condition (bolt extended).

- The opening (cable gland) in the door of the secure storage unit may not be greater than 100 sq mm (see mounting diagrams on Page 5 and following).
- The lock is designed for installation in secure storage units made of steel. Installation in storage units consisting of other material e.g. plastic is not allowed.
- Do not apply any kind of force (e.g. hammer blows) for screw fitting and adjustment of the lock.
- Lock to be installed covered and so as to prevent opening by boring.
- The two way key must be insertable without jamming.
- Use of the Kaba-Mauer key guide (see Fig. 1) is recommended. Considering DIN 2768-mH, the keyhole in the door of the secure storage unit should be dimensioned accordingly (see Fig. 1).

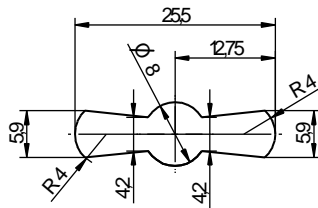
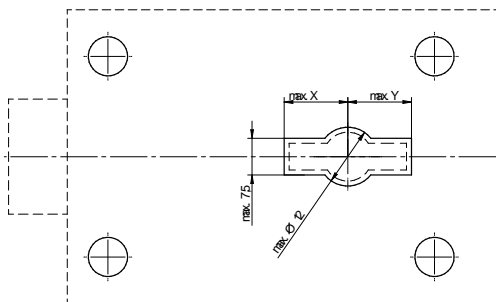

Fig. 1: Key guide 86101

- In cases where the Kaba-Mauer key guide or key carrier guide are not used, the maximum cross sectional area of the keyhole in the door of the secure storage unit and/or the lock armour plating may not exceed the dimensions given in Fig. 2 considering DIN 2768-mH. All dimensions deviating from these specifications are to be coordinated separately with the certification bodies (test houses).



Code-Combi B	X (mm)	Y (mm)
71161	17	12.5

Fig. 2 : Max. cross sectional area of keyhole

- For installation and adjustment of the lock on the door, make sure that the key can be inserted into the lock without applying force and without jamming. This can be achieved by mounting the lock according to the following pattern of mounting holes (Fig. 3). For further lock dimensions please refer to the Kaba Mauer Catalogue Sheet.

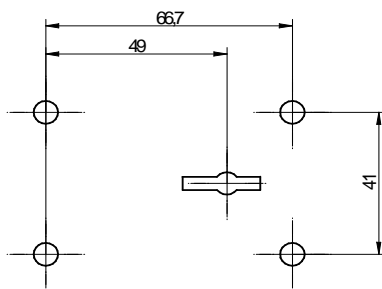

Fig. 3: Fastening hole pattern

**Technical data:**

- Lift height of bolt 12 mm
- Bolt extension in locked-out condition: approx. 14 mm
- Bolt width: 25,4 mm; Bolt height: 15 mm
- The maximum allowable force acting on the key bolt in opposite direction to the direction of locking, the maximum locking force and the lateral load acting on the bolt, correspond to 1 KN and should not exceed this value. Provision should be made design wise for bolt stoppers on both ends or for a bolt support.
- The bolt was according to EN1300 with a permanent load of 2,5 N over 10.000 cycles tested. These load should not be exceeded permanently.
- The actuating torque on the key / the spindle must not exceed 2.5 Nm.
- Fastening of the boltwork: via two M4 threads on the front end of the bolt head.

**3 Assembly**

Fig. 5: mounting steps

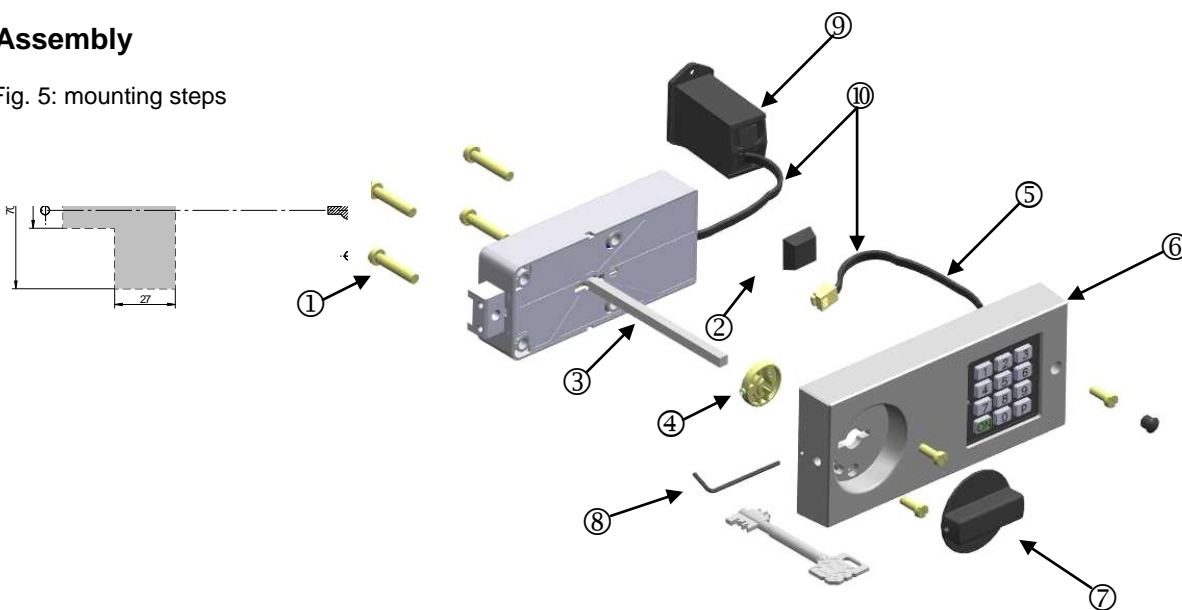

① Adjust and fix lock using the **fastening screws**.

② Stick on **self stick rubber buffers** on the safe door (see fig. 5). The dimensions and the position you will find in assembly drawings in chapter 6. All traces of grease on adhesion surface to be removed carefully before!



Notice: The rubber buffer must be used correctly, otherwise you loose the VdS conformity!

Fig. 5: stick on rubber buffers

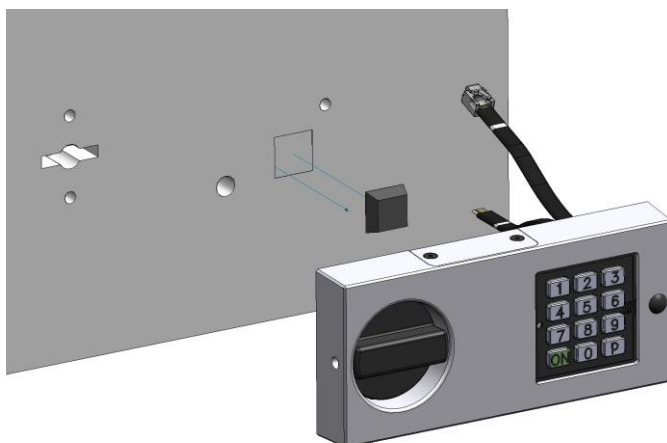

- ③ Insert **actuating spindle** as far as it will go with the bored end ahead (locking function warranted only this way).
- **Cutting to size of the actuating spindle (before assembly):** the required length results from the "clearance between mounting plane of lock to mounting plane of control unit" + "40 mm (tolerance – 0.5 mm). Cutting to size on the end **without** bore only!

Fig. 6:

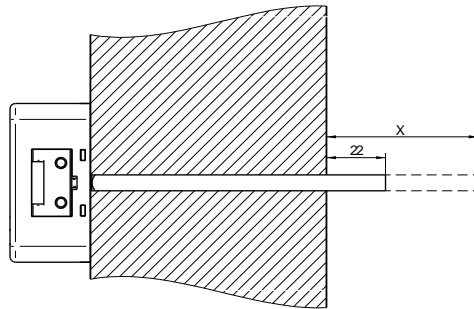

- ④ **Spindle retention element** to be slip-fitted on actuating spindle as shown by Fig. 6.
- Align headless screw and lower bore on control unit for inserting Allan key.
  - This requirement must be considered correspondingly for all the other mounting positions also.

Fig. 7:

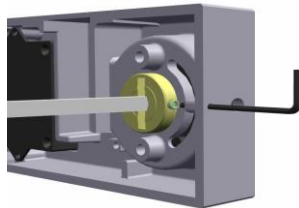

- ⑤ **Connecting cable of the control unit** to be routed through the door to the lock.
- Make sure that connecting cable is not damaged during installation. Cable sheathing or flexible leads must not be impaired, otherwise hazard of a short circuit. Protect the cable by protective hoses or plastic pipes in the area of transition and moving parts. Make sure also that the cable is not buckled or installed in pinched condition.
- ⑥ Align **aluminium control unit** and fix by 3 or 4 screws according to version of control unit involved.
- Cable penetrations must be deburred. See assembly drawing for cable penetrations and borehole dimensions .
  - Make sure that spindle retention can be rotated smoothly between control unit and surface of door. Re-work door surface as necessary.
- ⑦ Snap-on **actuating knob**.
- The guide pin on the knob (A) must engage in the sickle-shaped recess (B) of the control unit.
  - Position for bar dolly : **Bar horizontal, lock horizontal**  
**Bar vertical, lock vertical**

Fig. 8:

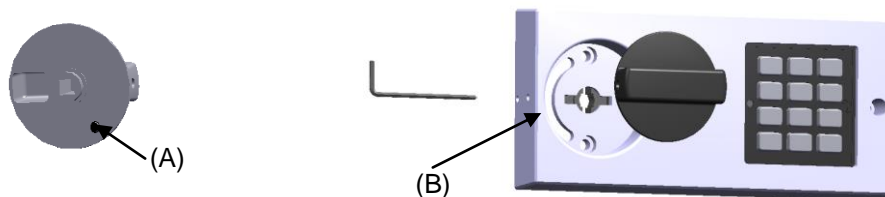

⑧ Fasten **spindle and knob** by means of an **Allan key 2.0 mm**.

- Adjustment of the assembly is correct once the bar dolly after slight clockwise turning jumps back by resilience to its horizontal home position.

Fig. 9:

Tighten headless screws

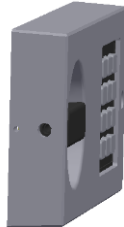

⑨ Join and fasten **battery compartment**. See assembly drawing (version with external battery compartment) for dimensions of penetrations).

⑩ For **cabling** plug connecting plugs according to instructions of the following table:

Marking on lock case	Connection for
Marked "input unit"	6 pole connecting cable to the electronic input system
Marked "power"	4 pole operating voltage (battery case)

- Confusion of the connecting cables does not produce any damage of the electronic system of the lock. The lock will not be operable in this case and must be connected correctly in accordance with the circuit diagram.
- Always press the latching clip of the plug against the plug housing for disconnecting plugs and sockets. Do not pull out plug reaching for the plug housing or the cable.

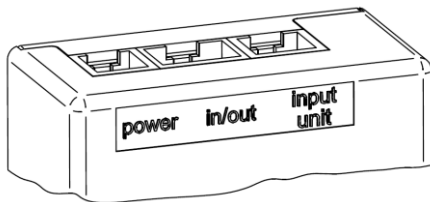

**4 Crimping of the 4-pole battery connector (version with battery compartment integrated in the door armature Optioncode IBF)**

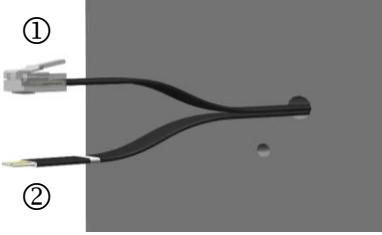
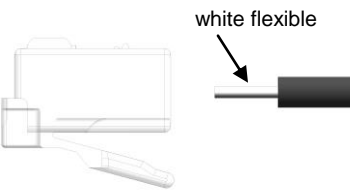
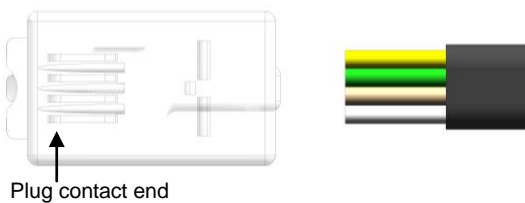
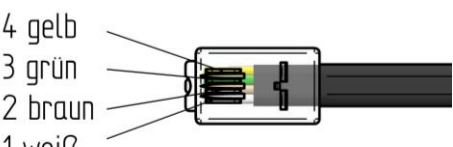
	<p>Route cable through provided feed-through opening:</p> <ul style="list-style-type: none"> <li>① Plug for keypad is factory crimped</li> <li>② Plug for battery (marked "Bat") must be insulated and crimped after feeding through the door</li> </ul>
	<p>Lateral view: Plug-in position</p>
	<p>Top view: Plug-in position</p>
	<p>Insert flexibles into grooves as far as they will go and crimp according to crimping tool instructions (as indicated by the manufacturer):</p> <ul style="list-style-type: none"> <li>4 yellow</li> <li>3 green</li> <li>2 brown</li> <li>1 white</li> </ul>

If a 6-pole connector is used, the pins 5 and 6 beside the yellow line (4) will stay empty. As pin 1 remains the white line.

**5 Crimping of the 6-pole battery connector (version with battery compartment integrated in the door armature)**

	<p>Route cable through provided feed-through opening:</p> <ul style="list-style-type: none"> <li>① Plug for keypad is factory crimped</li> <li>② Plug for battery (marked "Bat") must be insulated and crimped after feeding through the door</li> </ul>
	<p>Lateral view: Plug-in position</p>
	<p>Top view: Plug-in position</p>
	<p>Insert flexibles into grooves as far as they will go and crimp according to crimping tool instructions (as indicated by the manufacturer)</p>

If a 4-pole connector is used the line 5 (brown) and 6 (white) beside the green line (4) will stay outside the connector and are not used. As pin 1 remains the pink line!

## 6 Final check

- *Bei in den Beschlag integriertem Batteriefach (option code IBF) wird durch das Einlegen der Batterie der Batteriewechselkontakt aktiviert.* Every time the lock is opened a constant acoustic signal will be heard accompanied by alternate red/green flashing LED. It is imperative to have these signals cancelled.

### Cancellation of signals

1)	Press <b>ON</b>	
2)	Press <b>P</b>	
3)	Enter valid primary code	⊗
3)	Press <b>P</b>	⊗
5)	Press <b>9</b>	⊗

- Function of the lock to be checked according to operating instructions. Also check mechanical opening by the two-way key.
- Make sure when opening the lock that the bar dolly can be moved smoothly.



7 Mounting drawings

7.1 82132/33 Code-Combi B with aluminium control unit (option codes BAS, TOU, BSW)

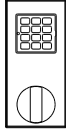
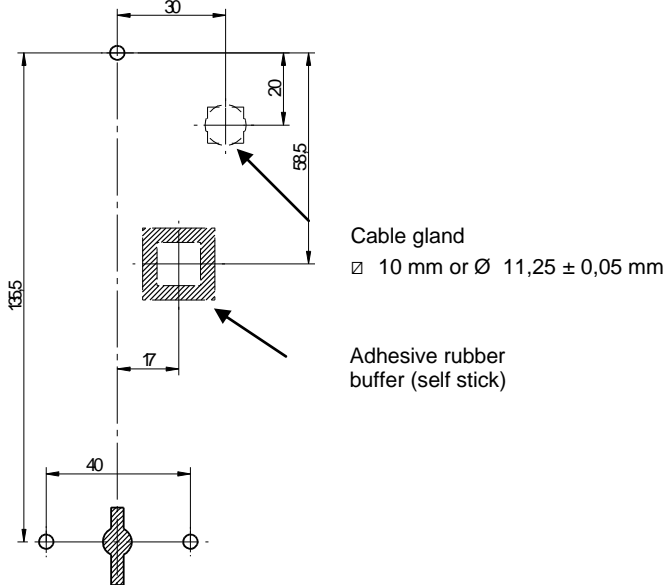
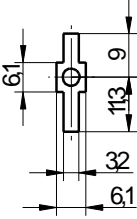
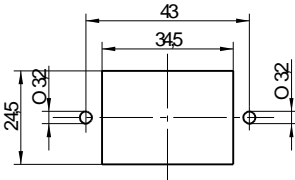
<p>Lock mounting position</p>	
<p>Control unit mounting position</p>	
<p>Door penetrations</p>	 <p>Cable gland  <math>\square</math> 10 mm or <math>\varnothing</math> 11,25 <math>\pm</math> 0,05 mm</p> <p>Adhesive rubber buffer (self stick)</p>
<p>Keyhole (in lock)</p>	
<p>Battery compartment separate</p>	 <p>Depth of battery compartment approx. 60 mm</p>

**7.2 82132/33 Code-Combi B with aluminium control unit (option codes BAS, TRL, BSW)**

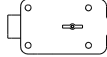
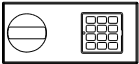
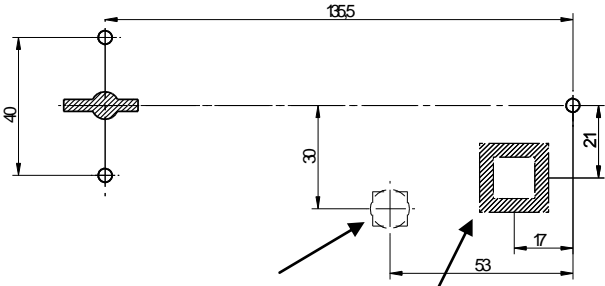
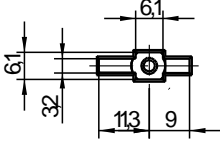
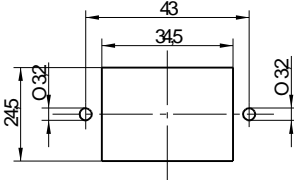
<p><b>Lock mounting position</b></p>	
<p><b>Control unit mounting position</b></p>	
<p><b>Door penetrations</b></p>	 <p>Cable glands          □ 10 mm or          Ø 11,25 ± 0,05 mm</p> <p>Adhesive buffer          (self stick)</p>
<p><b>Keyhole (in lock)</b></p>	
<p><b>Battery compartment separate</b></p>	 <p>Depth of battery compartment approx. 60 mm</p>

**7.3 82132/33 Code-Combi B with aluminium control unit (option codes BAS, TUO, BSW)**

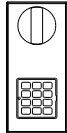
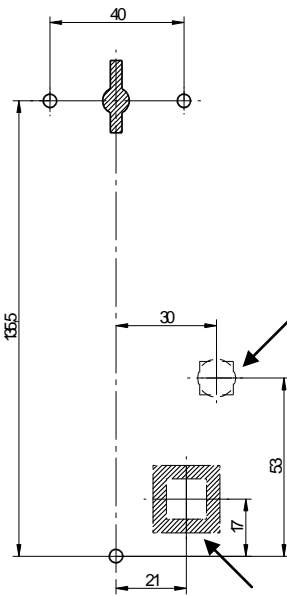
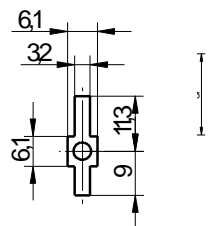
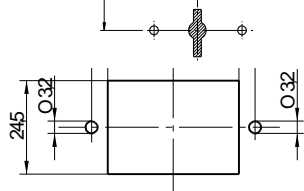
<p><b>Lock mounting position</b></p>	
<p><b>Control unit mounting position</b></p>	
<p><b>Door penetrations</b></p>	 <p>Cable gland  <math>\square</math> 10 mm or  <math>\varnothing</math> 11,25 <math>\pm</math> 0,05 mm</p> <p>Adhesive buffer          (self stick)</p>
<p><b>Keyhole (in lock)</b></p>	
<p><b>Battery compartment separate</b></p>	 <p>Depth of battery compartment approx. 60 mm</p>

**7.4 82132/33 Code-Combi B with aluminium control unit (option codes BAS, TLR, BSW)**

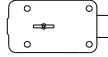
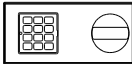
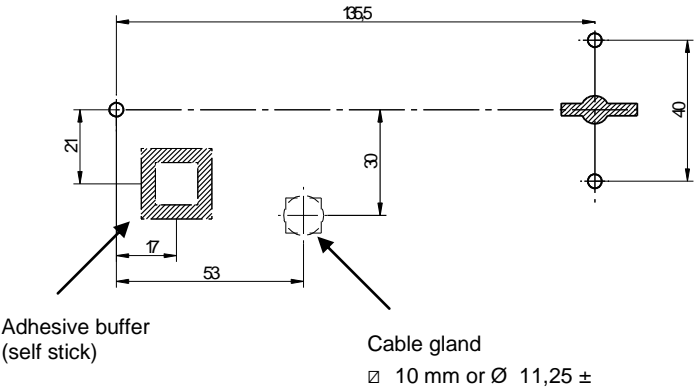
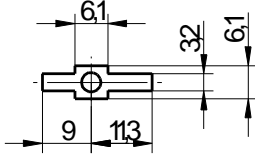
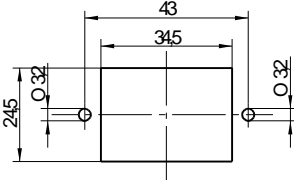
<p><b>Lock mounting position</b></p>	
<p><b>Control unit mounting position</b></p>	
<p><b>Door penetrations</b></p>	 <p>Adhesive buffer (self stick)</p> <p>Cable gland  <math>\square</math> 10 mm or <math>\varnothing</math> 11,25 <math>\pm</math></p>
<p><b>Keyhole (in lock)</b></p>	
<p><b>Battery compartment separate</b></p>	 <p>Depth of battery compartment approx. 60 mm</p>

**7.5 82132/33 Code-Combi B with aluminium control unit (option codes BAS, TRS, BSS, bolt downwards)**

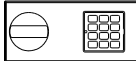
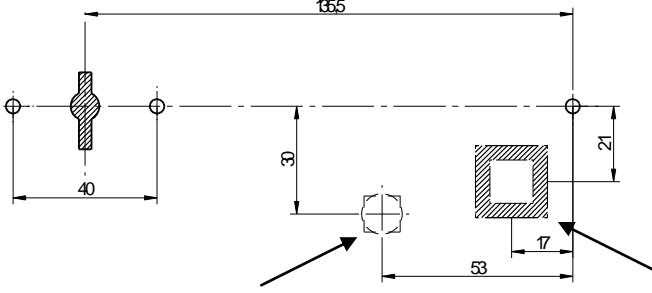
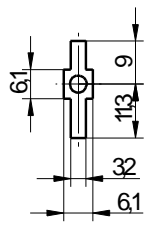
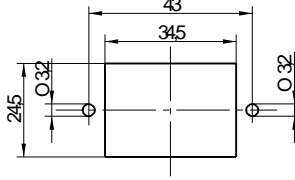
<p><b>Lock mounting position</b></p>	
<p><b>Control unit mounting position</b></p>	
<p><b>Door penetrations</b></p>	 <p>Cable gland  <math>\varnothing</math> 10 mm or <math>\varnothing</math> 11,25 <math>\pm</math> 0,05 mm</p> <p>Adhesive buffer          (self stick)</p>
<p><b>Keyhole (in lock)</b></p>	
<p><b>Battery compartment separate</b></p>	 <p>Depth of battery compartment approx. 60 mm</p>

**7.6 82132/33 Code-Combi B with aluminium control unit (option codes BAS, TRS, BSS, bolt upwards)**

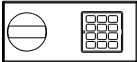
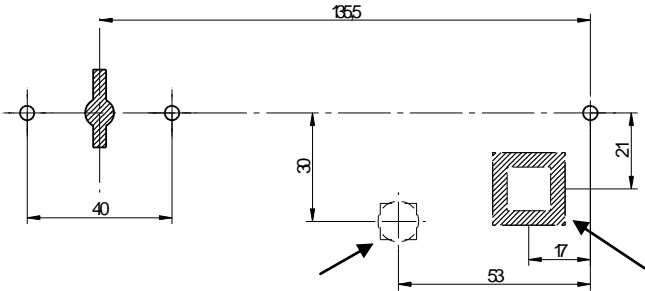
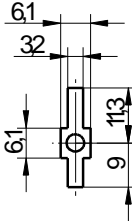
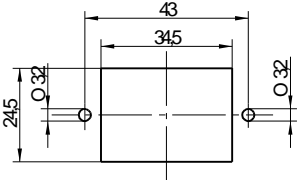
<p><b>Lock mounting position</b></p>	
<p><b>Control unit mounting position</b></p>	
<p><b>Door penetrations</b></p>	 <p>Cable gland  <math>\square</math> 10 mm or <math>\varnothing</math> 11,25 <math>\pm</math> 0,05 mm</p> <p>Adhesive buffer          (self stick)</p>
<p><b>Keyhole (in lock)</b></p>	
<p><b>Battery compartment separate</b></p>	 <p>Depth of battery compartment approx. 60 mm</p>

**7.7 82132/33 Code-Combi B with aluminium control unit (option codes BAS, TLS, BSS, bolt downwards)**

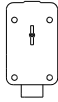
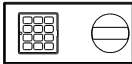
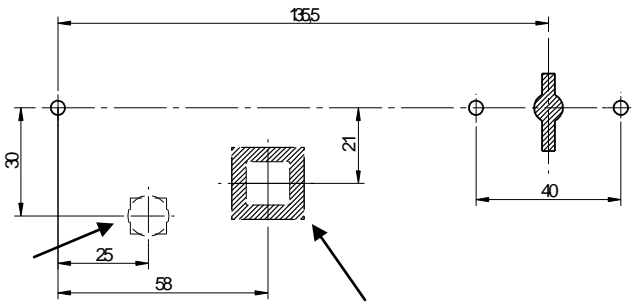
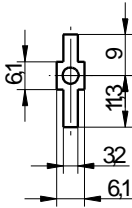
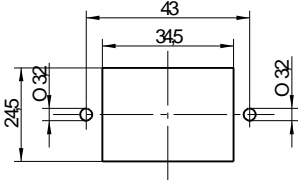
<p><b>Lock mounting position</b></p>	
<p><b>Control unit mounting position</b></p>	
<p><b>Door penetrations</b></p>	 <p>Cable gland  <math>\square</math> 10 mm or <math>\varnothing</math> 11,25 <math>\pm</math> 0,05 mm      Adhesive buffer (self stick)</p>
<p><b>Keyhole (in locky )</b></p>	
<p><b>Battery compartment separate</b></p>	 <p>Depth of battery compartment approx. 60 mm</p>

**7.8 82132/33 Code-Combi B with aluminium control unit (option codes BAS, TLS, BSS, bolt upwards)**

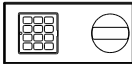
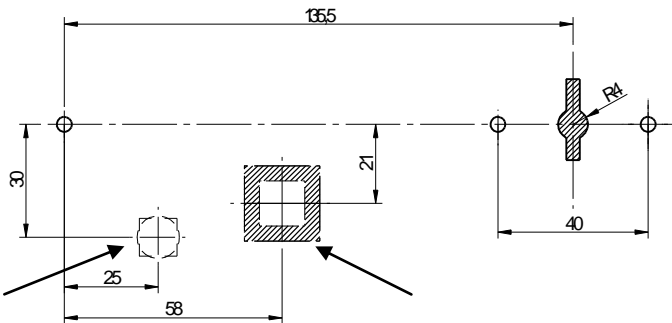
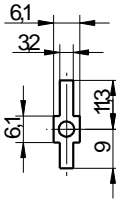
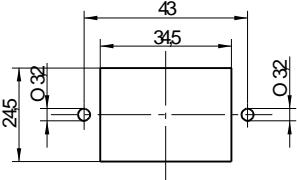
<p><b>Lock mounting position</b></p>	
<p><b>Control unit mounting position</b></p>	
<p><b>Door penetrations</b></p>	 <p>Cable gland  <math>\square</math> 10 mm or <math>\varnothing</math> 11,25 <math>\pm</math> 0,05 mm</p> <p>Adhesive buffer (self stick)</p>
<p><b>Keyhole (in lock)</b></p>	
<p><b>Battery compartment separate</b></p>	 <p>Depth of battery compartment approx. 60 mm</p>

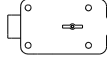
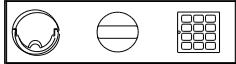
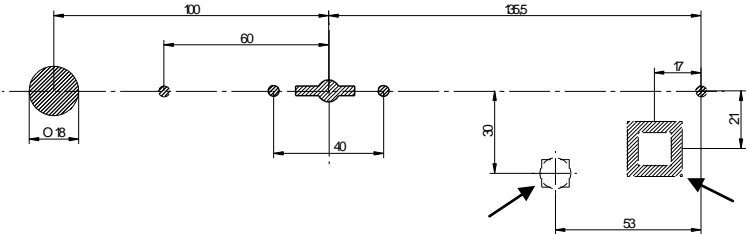
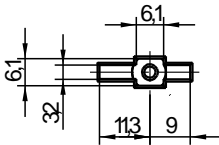
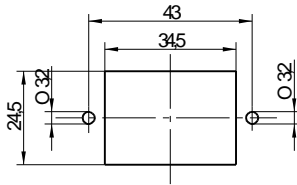

**7.9 82132/33 Code-Combi B with aluminium control unit (option codes BAK, TRL)**

<p><b>Lock mounting position</b></p>	
<p><b>Control unit mounting position</b></p>	
<p><b>Door penetrations</b></p>	 <p>Cable gland              □ 10 mm or Ø 11,25 ± 0,05 mm</p> <p>Adhesive buffer              (self stick)</p>
<p><b>Keyhole (in lock)</b></p>	
<p><b>Battery compartment separate</b></p>	 <p>Depth of battery compartment approx. 60 mm</p>

**7.10 82132/33 Code-Combi B with aluminium control unit (option codes BAH, TOU, BSW)**

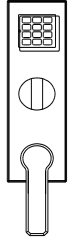
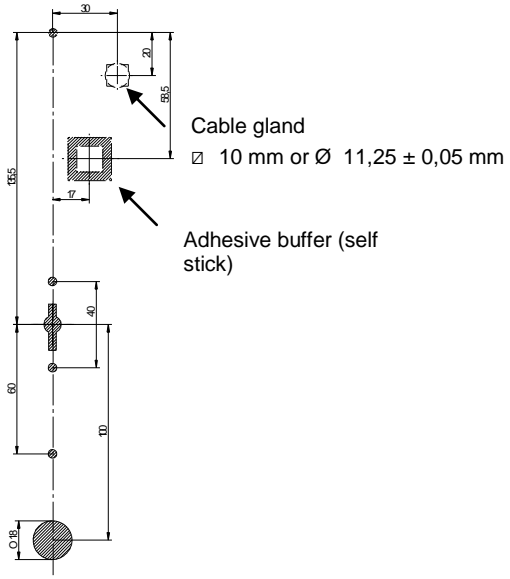
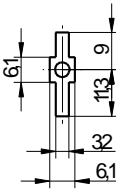
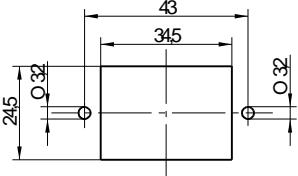
<p><b>Lock mounting position</b></p>	
<p><b>Control unit mounting position</b></p>	
<p><b>Door penetrations</b></p>	 <p>Cable gland  <math>\square 10 \text{ mm}</math> or <math>\text{Ø } 11,25 \pm 0,05 \text{ mm}</math></p> <p>Adhesive buffer (self stick)</p>
<p><b>Keyhole (in lock)</b></p>	
<p><b>Battery compartment separate</b></p>	 <p>Depth of battery compartment approx. 60 mm</p>

**7.11 82132/33 Code-Combi B with aluminium control unit**

Unter dem Punkt 6 Montageskizzen (Seite 6 bis 15) ist das Kabeldurchführungsloch (max. 100 mm<sup>2</sup>) zeichnerisch idealerweise positioniert. Abweichend davon wird es den Schrank-, Tresor und Anlagenbauern ermöglicht, das Kabeldurchführungsloch (siehe unten Abb. 9 bis 14) auch innerhalb der grau gezeichneten Fläche zu positionieren und zu fertigen.

Hinweis:

- Es darf die Kabelzugentlastung der Bedieneinheit (Tastatur) nicht zerstört werden.
- Die Mikroschalterfunktion (Schaltbereich des Mikroschalter) darf durch die Kabelverlegung nicht beeinträchtigt werden und muss bleibend sichergestellt sein.

Schloss waagrecht / Beschlag waagrecht (Optionscodes BAS TRW + TLW)



Abb. 10



Abb. 11

Schloss senkrecht / Beschlag waagrecht (Optionscodes BAS TRS + TLS)

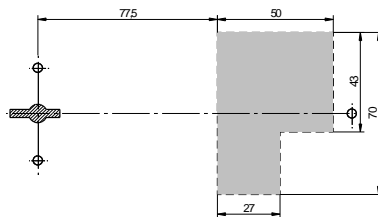

Abb. 12

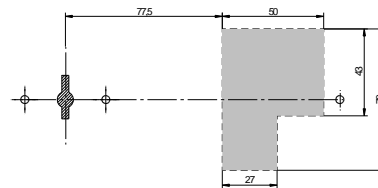

Abb. 13

Schloss senkrecht / Beschlag senkrecht (Optionscodes BAS TOS + TUS)

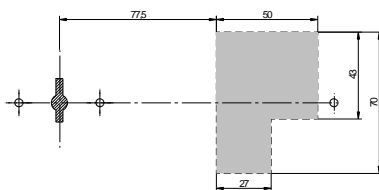

Abb. 13

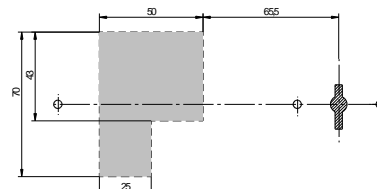
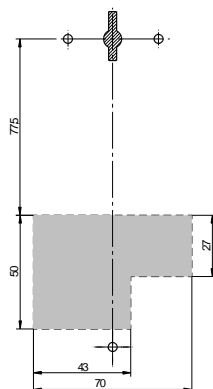
Abb. 14