

8000 Series

Grade 1 exit device

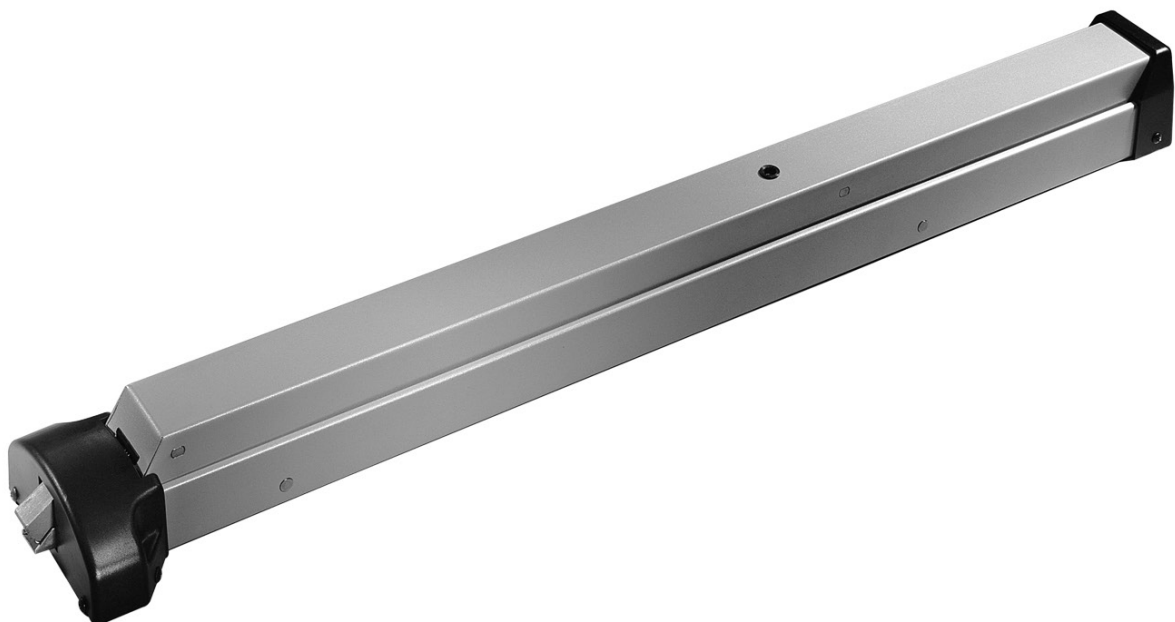

8000 Series

Grade 1 exit device with deadlocking latch bolts

8000 Series Grade 1 exit devices

- 3** Certification & specifications
- 4** Data & features
- 4** Options
- 5** ANSI functions
- 6** Ordering guide
- 6** Handing

Applications & listings

- 7** Single doors
- 7** Pair of doors with removable mullions
- 7** Pair of doors

Exit devices

- 8** 8300 exit device functions
- 9** 8300 strikes & minimum stile
- 10** 8400 exit device functions
- 11** 8400 strikes & minimum stile
- 13** Trim ordering guide
- 13** Lever & knob styles
- 14** Trim
- 20** Cylinder specifications
- 20** Accessories
- 21** Electrical functions
- 22** Mullions

DORMA USA quality and environmental management systems in Reamstown, PA and Steeleville, IL are certified to ISO 9001:2008 and ISO 14001:2004.



Intertek



Intertek

8000 Series

Certification & specifications

8000 Series exit devices minimize forced entry while offering a low-cost solution to life safety requirements.

Certification

- Certified/listed to ANSI/BHMA 156.3, Grade 1 for exit devices.
- U.L. and C.U.L. listed under their continuing reinspection programs and conforms to standards U.L. 10C positive pressure testing.
- Complies with NFPA 101 life safety code. Fire rated devices comply with NFPA 80 fire doors and windows.
- Devices, trim, pulls, and levers comply with the Americans for Disabilities Act, 1994, and ICC A117.1 for accessible and usable buildings and facilities.
- Contributes to U.S. Green Building Council, LEED MR Credits 2.1, 4.1, 4.2, and 5.1.
- Listed with the California Department of Forestry and Fire Protection, Office of the State Fire Marshal.
- Hurricane code approved to Miami-Dade County Florida acceptance No. 06-912.04.



Specifications

- All exit devices shall be 8000 Series rim, surface vertical rod or surface vertical rod "less bottom rod" devices.
- All device touchbars, rails, and integral parts shall be constructed of solid steel with ABS thermo-plastic end caps and covers.
- Non-labeled units to have hex-key dogging standard.
- Fire rated versions shall be available for labeled applications.
- All surface vertical rod devices shall have pullman type latch bolts for the top latch with a round slide bolt bottom latch.
- All units shall offer trim options ranging from no trim, exit only blank trim, entrance by trim when touchbar is dogged, entrance when latch bolt is retracted by key, and entrance by lever set with a key to lock and unlock lever.
- Device touchbar, rail, and rods shall be available with a powder coated finish or base material stainless steel.

Optional specifications

- Non-labeled devices to have cylinder dogging. Mortise cylinder included.
- All surface vertical rod devices to have pullman type bottom latch bolt.
- All surface vertical rod devices to have extended top rod.
- All surface vertical rod devices to be available less bottom rod.
- Devices to have monitor switch in the touchbar to provide local and/or remote notification when the touchbar is depressed.
- Devices to have electric bolt retraction to provide remote access from the secure side of the door. Can also be used in conjunction with an automatic door operator.
- Devices to have latch monitor for monitoring the latch bolt status.
- Devices to have one of the following exit alarm options: battery powered exit alarm, battery powered exit alarm with a four minute reset, or direct wired exit alarm.
- Devices to use a glass lite shim kit to raise the device from the door surface and avoid glass lite molding.
- All labeled wood or composite door devices must use sex bolts.

Finishes

Exit device finishes

- Aluminum: 689
- Aluminum with SS touchbar: 689 / 630 TB
- Bronze: 691 (dull) or 695 (dark duranodic)
- Black: 693
- Gold: 696
- Clear powder coating: Specify P

Note: Covers and end caps are black ABS thermoplastic.

Trim finishes

- Aluminum: 689
- Bronze: 691 (dull) or 695 (dark duranodic)
- Black: 693
- Chrome: 626 (satin)
- Gold: 696
- Clear powder coating: Specify P

Warranty

For details, refer to **Limited Warranty** on our website at go.dormakaba.com/Terms-DA

Data & features

| 8000 Series data & features | Model 8300 | Model 8400 |
|---|------------|------------|
| U.L. listed for hazard | ● | ● |
| U.L. listed for labeled fire doors (prefix F) | ● | ● |
| Size A doors 34" – 48" wide | ● | ● |
| Size B doors 28" – 36" wide | ● | ● |
| Size C doors 22" – 36" wide | ● | ● |
| Door height up to 7' | N/A | ● |
| Door height up to 8' | N/A | ● |
| Door height up to 10' (specify ETR) | N/A | ● |
| Door thickness 1-3/4" to 2-1/4" | ● | ● |
| Device non-handed | ● | N/A |
| Device handed but field-reversible | N/A | ● |
| Rigid trim (specify suffix R) | ● | ● |
| Hex key dogging (nonfire-rated units only) | ● | ● |
| Cylinder dogging (nonfire-rated units only) | ● | ● |
| Round bottom slide bolt (default SB) | N/A | ● |
| Deadlocking pullman type bottom latch bolt (specify PB) | N/A | ● |
| Less bottom rod (specify LB) | N/A | ● |
| Glass lite shim kit (specify GK8000) | ● | ● |
| Electric latch bolt retraction (specify ES) | ○ | ○ |
| Monitor switch in touchbar (specify MS) | ● | ● |
| Latch monitor (specify LM) | ● | ● |
| Exit alarm (specify BPA, BPAR or DWA) | ● | ● |
| Sex nuts (specify SNB/quantity) | ● | ● |
| Hurricane code rated (specify HC) | ● | ● |

● – Standard feature ○ – Optional feature N/A – Not applicable

Options

| | |
|---------------|--|
| BPA | Battery powered exit alarm |
| BPAR | Battery powered exit alarm, (4) minute reset |
| DWA | Direct wired exit alarm |
| CD | Cylinder dogging |
| ES | Latch retraction (8300, 8400) |
| ETR | Top rod extension (8400) |
| GK8000 | Glass lite shim kit |
| LB | Less bottom rod (8400) |
| LM | Latch monitor |
| MS | Monitor switch |
| PB | Pullman bottom latch, vertical rod only (8400) |
| SNB | Sex nuts, specify quantity |
| R | Rigid trim |
| HC | Hurricane code rated |

ANSI functions

| ANSI function | Function description | Type 1 rim exit device | Type 2 surface vertical rod exit device |
|---------------|---|--|--|
| 01 | Exit Only – No Trim. | 8300 or F8300 | 8400 or F8400 |
| 02 | Entrance by trim when actuating bar is locked down. | 8300 x (trim) 8PDT / 8P02 / 8ODTP 8R02R / 8C02R PTS02 / PRS02 | 8400 x (trim) 8PDT / 8P02 / 8ODTP 8R02R / 8C02R PTS02 / PRS02 |
| 03 | Entrance by trim when latch bolt is retracted by key. Key removable only when locked. | 8300 or F8300 x (trim) 8P02 / 8O03 / 8P03 / 8O03P 8HK03 / 8HK03J / 8HR03 / 8HR03J / 8HC03 / 8HC03J / 8HG03 / 8HG03J 8K03 / 8K03J / 8R03 / 8R03J / 8C03 / 8C03J / 8G03 / 8G03J NPS03 / PTS03 / PRS03 | 8400 or F8400 x (trim) 8P02 / 8O03 / 8P03 / 8O03P 8HK03 / 8HK03J / 8HR03 / 8HR03J / 8HC03 / 8HC03J / 8HG03 / 8HG03J 8K03 / 8K03J / 8R03 / 8R03J / 8C03 / 8C03J / 8G03 / 8G03J NPS03 / PTS03 / PRS03 |
| 05 | Entrance by thumbpiece. Key locks or unlocks thumbpiece. | 8300 or F8300 x (trim) HTS05 / HRS05 | 8400 or F8400 x (trim) HTT05 / HRT05 |
| 06 | Entrance by thumbpiece only when released by key. Key removable only when locked. | 8300 or F8300 x (trim) HTS06 / HRS06 | 8400 or F8400 x (trim) HTT06 / HRT06 |
| 08 | Entrance by lever or knob. Key locks or unlocks knob or lever. | 8300 or F8300 x (trim) 8HK08 / 8HK08J / 8HR08 / 8HR08J / 8HC08 / 8HC08J / 8HG08 / 8HG08J 8K08 / 8K08J / 8R08 / 8R08J / 8C08 / 8C08J / 8G08 / 8G08J | 8400 or F8400 x (trim) 8HK08 / 8HK08J / 8HR08 / 8HR08J / 8HC08 / 8HC08J / 8HG08 / 8HG08J 8K08 / 8K08J / 8R08 / 8R08J / 8C08 / 8C08J / 8G08 / 8G08J |
| 09 | Entrance by lever or knob when unlocked by key. Key removable when locked. | 8300 or F8300 x (trim) 8HK09 / 8HK09J / 8HR09 / 8HR09J / 8HC09 / 8HC09J / 8HG09 / 8HG09J | 8400 or F8400 x (trim) 8HK09 / 8HK09J / 8HR09 / 8HR09J / 8HC09 / 8HC09J / 8HG09 / 8HG09J |
| 22 | Entrance by thumbpiece (no cylinder). Trim always active. | 8300 or F8300 x (trim) HTS22 / HRS22 | 8400 or F8400 x (trim) HTS22 / HRS22 |
| 23 | Entrance by lever or knob (no cylinder). Trim always active. | 8300 or F8300 x (trim) 8HK23 / 8HK23J / 8HR23 / 8HR23J / 8HC23 / 8HC23J / 8HG23 / 8HG23J 8R23 / 8C23 / 8K23 / 8G23 | 8400 or F8400 x (trim) 8HK23 / 8HK23J / 8HR23 / 8HR23J / 8HC23 / 8HC23J / 8HG23 / 8HG23J 8R23 / 8C23 / 8K23 / 8G23 |

Ordering guide

How to order 8000 Series exit devices

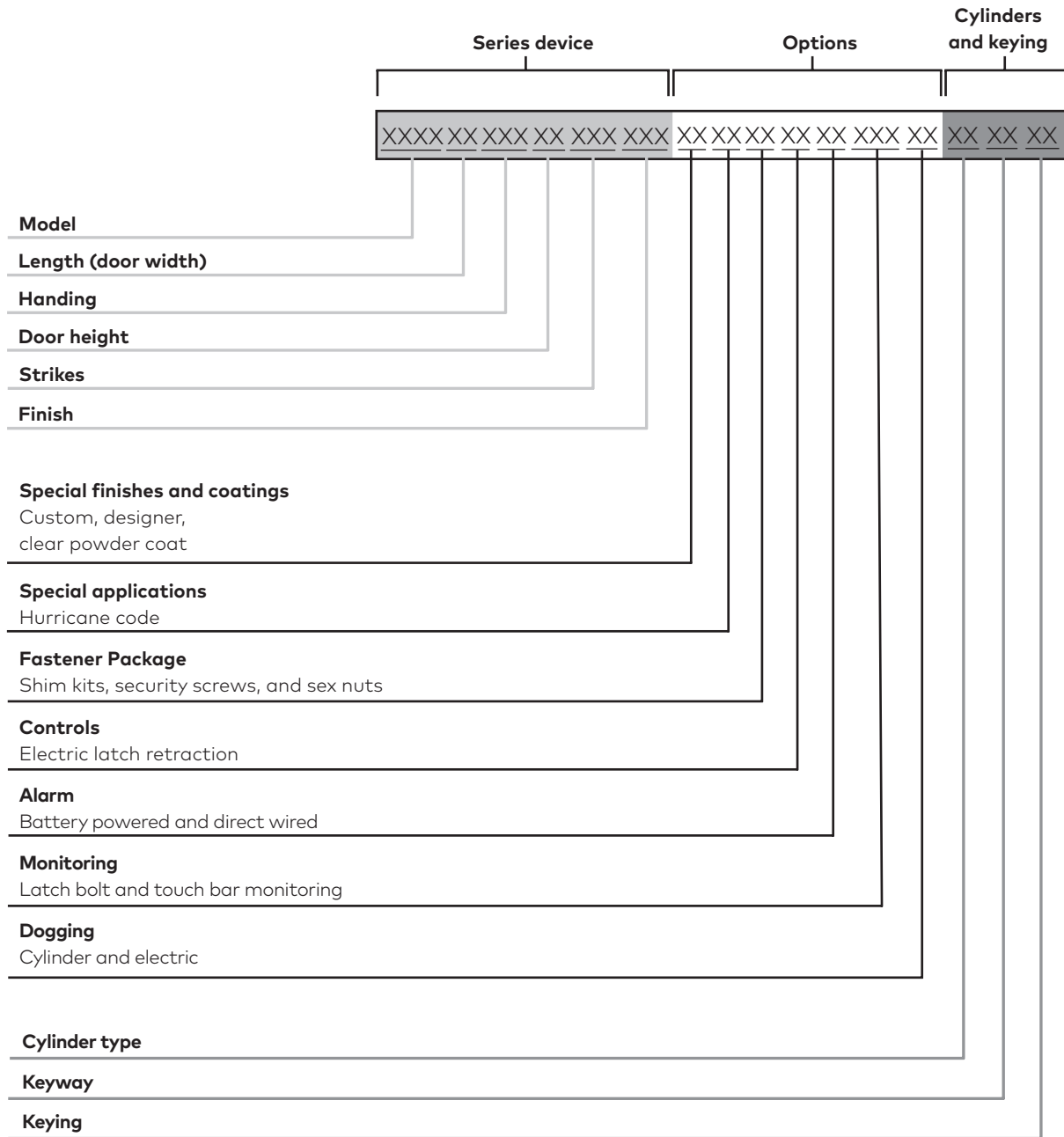

Handing

Right-hand reverse bevel (RHR)

Outside

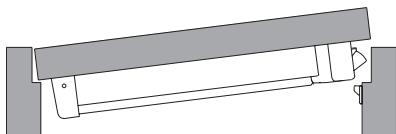

Push side





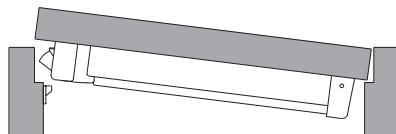





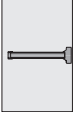

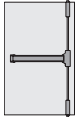

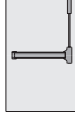

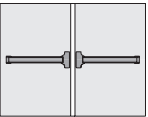
Left-hand reverse bevel (LHR)

Outside

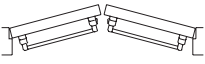
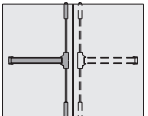

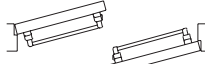
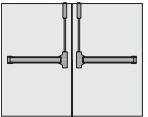
Push side

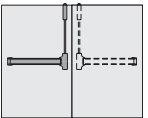
Applications & listings































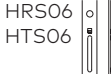



| Model | Door material | Max. door opening |  Door ratings | Applications |
|--|---------------|-------------------|--|---|
| Single doors | | | | |
| Rim 8300 | Wood/steel | 4' x 8' | Devices are panic listed only | Surface applied (1) point latching  |
| Rim F8300  | Steel | 4' x 8' | 3 hour | |
| | Wood | 4' x 8' | 1-1/2 hour | |
| Surface vertical rod 8400 | Wood/Steel | 4' x 10' | Devices are panic listed only | Surface applied (2) point latching  |
| Surface vertical rod F8400  | Steel | 4' x 10' | 3 hour | |
| | Wood | 4' x 10' | 1-1/2 hour ³ | |
| Surface vertical rod (less bottom rod) 8400 LB | Wood/Steel | 4' x 10' | Devices are panic listed only | Surface applied (1) point latching  |
| Surface vertical rod (less bottom rod) F8400 LB  | Steel | 4' x 10' | 3 hour | |
| | Wood | 4' x 10' | 1-1/2 hour ³ | |
| Pair of doors with removable mullion | | | | |
| Rim x rim 8300 x 8300 | Wood/Steel | 8' x 8' | Devices are panic listed only | (2) independent active doors with removable mullion  |
| Rim x rim F8300 x F8300  | Steel | 8' x 8' | 3 hour | (1) point latching |
| | Wood | 8' x 8' | 1-1/2 hour | |
| Pair of doors NOTE: A pair of doors using a rim x surface vertical rod are panic listed only for an 8' x 8' maximum opening. | | | | |
| Surface vertical rod 8400 x 8400 | Wood/steel | 8' x 10' | Devices are panic listed only | (2) independent doors with (2) point latching  |
| Surface vertical rod F8400 x F8400  | Steel | 8' x 10' | 1-1/2 Hour ² |  (swing same direction) |
| | Wood | 8' x 8' | 1-1/2 Hour | |
| | Wood | 8' x 10' | 1-1/2 Hour ³ | |
| Surface vertical rod 8400 x 8400 | Wood/steel | 8' x 10' | Devices are panic listed only | (2) independent doors with (2) point latching  |
| Surface vertical rod F8400 x F8400  | Steel | 8' x 10' | 3 Hour |  (swing opposite direction) |
| | Wood | 8' x 8' | 1-1/2 hour | |
| | Wood | 8' x 10' | 1-1/2 hour ³ | |
| Surface vertical rod (less bottom rod) 8400 LB x 8400 LB | Wood/steel | 8' x 10' | Devices are panic listed only | (2) independent doors with (1) point latching  |
| Surface vertical rod (less bottom rod) F8400 LB x F8400 LB  | Steel | 8' x 10' | 1-1/2 hour ^{1,2} |  (swing same direction) |
| | Wood | 8' x 10' | 1-1/2 hour ^{1,3} | |
| Surface vertical rod (less bottom rod) 8400 LB x 8400 LB | Wood/steel | 8' x 10' | Devices are panic listed only | (2) independent doors with (1) point latching  |
| Surface vertical rod (less bottom rod) F8400 LB x F8400 LB  | Steel | 8' x 10' | 3 hour ¹ |  (swing opposite direction) |
| | Wood | 8' x 10' | 1-1/2 hour ^{1,3} | |

1. Fire rated pairs using **Less Bottom Rod** devices require the supplied door popper. With the absence of bottom rods, the popper holds the bottoms of the doors together in the event of fire.

2. Pairs of doors swinging in the same direction cannot use two vertical rod exit devices with an overlapping astragal. Pairs of doors rated greater than 1-1/2 hours require a steel overlapping astragal. Currently, no door manufacturers offer over 90 min. with doors swinging in the same direction.

3. Consult wood door manufacturers for current U.L. listings.

8300 exit device functions

| Model | Function | Operation | Trim |
|---------------|----------|---|--|
| 8300 F8300 | 01 | Exit Only (no trim) | |
| 8300 F8300 | DT | Dummy Trim | 8ODT  NPSDT  8HDT  |
| 8300 | 02 | Entrance by trim when actuating bar is locked down. | 8P02  8PDT  PRS02  PRT02  8x02R  8ODTP  |
| 8300 F8300 | 03 | Entrance by trim when latch bolt is retracted by key. Key removable only when locked. | 8P02  8O03  NPS03  8Hx03  8K03  8x03  8O03P  8P03  PRS03  PTS03  |
| 8300 F8300 | 05 | Entrance by thumbpiece. Key locks or unlocks thumbpiece. | HRS05  HTS05  |
| 8300 F8300 | 06 | Entrance by thumbpiece only when released by key. Key removable only when locked. | HRS06  HTS06  |
| 8300 F8300 | 08 | Entrance by lever or knob. Key locks or unlocks lever or knob. | 8Hx08  8K08  8x08  8Hx08J  8K08J  8x08J  |
| 8300 F8300 | 09 | Entrance by lever or knob when unlocked by key. Key removable only when locked. | 8Hx09  8Hx09J  |
| 8300 | 22 | Entrance by thumbpiece (no cylinder). Trim always active. | HRS22  HTS22  |
| 8300 F8300 | 23 | Entrance by lever or knob (no cylinder). Lever or knob always active. | 8Hx23  8K23  8x23  |

Note: Where x appears above, x = lever style. See page 13 for details.

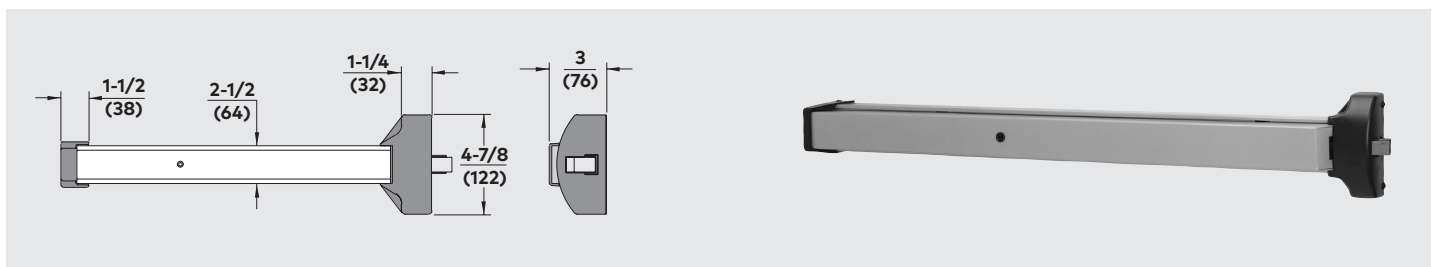

8300 strikes & minimum stile

8300 strike

No. 463 (standard)

Standard strike with 8300 and F8300

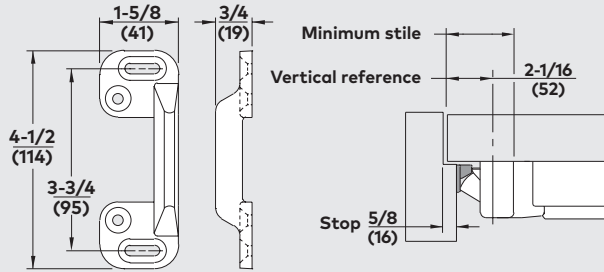

| Trim | *Minimum stile |
|--------------------------|----------------|
| No trim, 8P02 | 4 (102) |
| 8PDT, 8P03 | 4 (102) |
| 8ODT, 8ODTP, 8O03, 8O03P | 4-1/2 (114) |
| 8x, 8Hx | 4-7/16 (113) |

No. 430 (optional)

Box strike with 8300

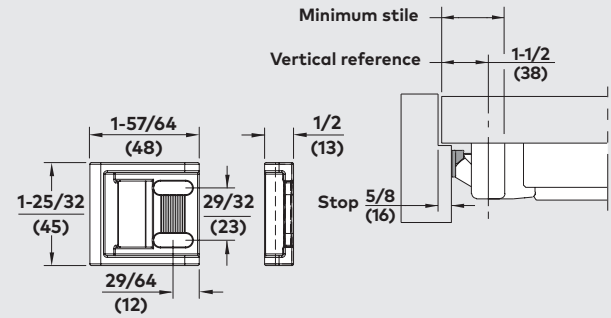

| Trim | *Minimum stile |
|--------------------------|----------------|
| No trim, 8P02 | 3-13/16 (97) |
| 8PDT, 8P03 | 4-1/8 (105) |
| 8ODT, 8ODTP, 8O03, 8O03P | 4-7/16 (113) |
| 8x, 8Hx | 4-1/4 (108) |

No. 486 (optional)

Roller strike

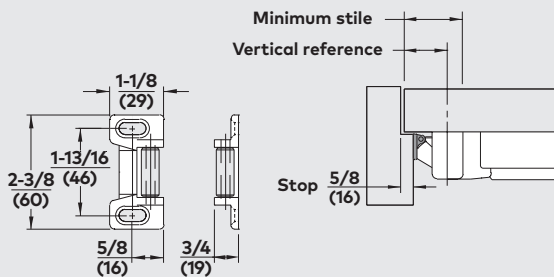

| Trim | *Minimum stile | Vertical reference |
|--------------------------|----------------|--------------------|
| No Trim, 8P02 | 4 (102) | 2-1/16 (52) |
| 8PDT, 8P03 | 4 (102) | 2-1/16 (52) |
| 8ODT, 8ODTP, 8O03, 8O03P | 4-1/2 (114) | 2-1/16 (52) |
| 8x, 8Hx | 4-7/16 (113) | 2-1/16 (52) |

No. 320 (optional)

Overlap strike

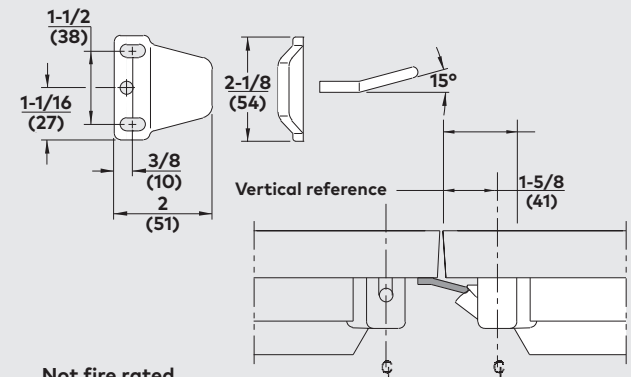

































Not fire rated

| Trim | *Minimum stile |
|--------------------------|----------------|
| No Trim, 8P02 | 4-1/16 (103) |
| 8PDT, 8P03 | 4-1/16 (103) |
| 8ODT, 8ODTP, 8O03, 8O03P | 4-1/16 (103) |
| 8x, 8Hx | 4 (102) |

* Minimum stile dimensions accommodate standard device touchbar widths shown. For smaller stiles, consult factory for optional touchbar lengths.

Note: Where x appears above, x = lever style. See page 13 for details.

8400 exit device functions

| Model | Function | Operation | Trim |
|---------------|----------|---|--|
| 8400 F8400 | 01 | Exit only (no trim) | |
| 8400 F8400 | DT | Dummy trim | 8ODT  NPSDT  8HDT  |
| 8400 | 02 | Entrance by trim when actuating bar is locked down. | 8P02  8PDT  PRS02 PRT02  8x02R  8ODTP  |
| 8400 F8400 | 03 | Entrance by trim when latch bolt is retracted by key. Key removable only when locked. | 8P02  8O03  NPS03  8Hx03  8K03  8x03  8O03P  8P03  PRS03 PTS03  |
| 8400 F8400 | 05 | Entrance by thumbpiece. Key locks or unlocks thumbpiece. | HRS05  HTS05  |
| 8400 F8400 | 06 | Entrance by thumbpiece only when released by key. Key removable only when locked. | HRS06  HTS06  |
| 8400 F8400 | 08 | Entrance by lever or knob. Key locks or unlocks lever or knob. | 8Hx08  8K08  8x08  8Hx08J  8K08J  |
| 8400 F8400 | 09 | Entrance by lever or knob when unlocked by key. Key removable only when locked. | 8Hx09  8Hx09J  |
| 8400 | 22 | Entrance by thumbpiece (no cylinder). Trim always active. | HRS22  HTS22  |
| 8400 F8400 | 23 | Entrance by lever or knob (no cylinder). Lever or knob always active. | 8Hx23  8K23  8x23  |

Note: Where x appears above, x = lever style. See page 13 for details.

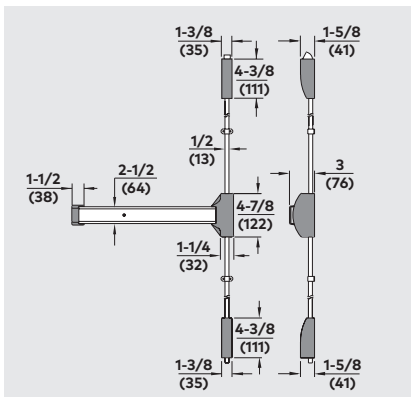

8400 strikes & minimum stile

8400 strikes

No. 426 (standard)

Top strike 8400, F8400, 8400 LB and F8400 LB

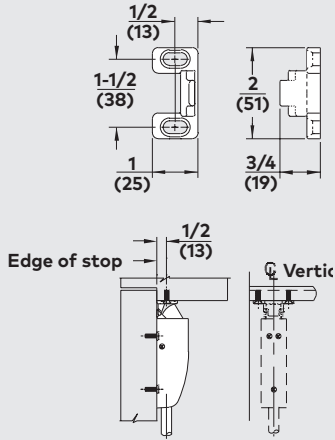

No. 439 (standard)

Bottom strike 8400 and F8400

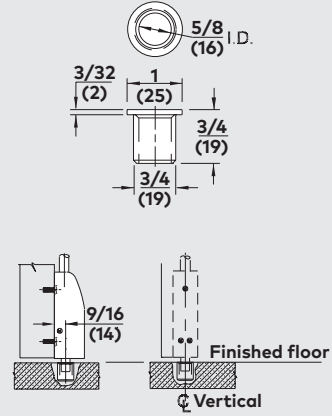

No. 340 (optional)

For bottom slide bolt.

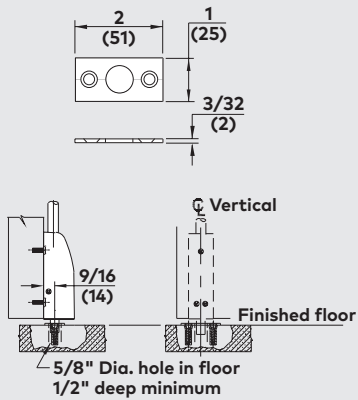

No. 431 (optional)

Used with optional pullman type latch bolt.

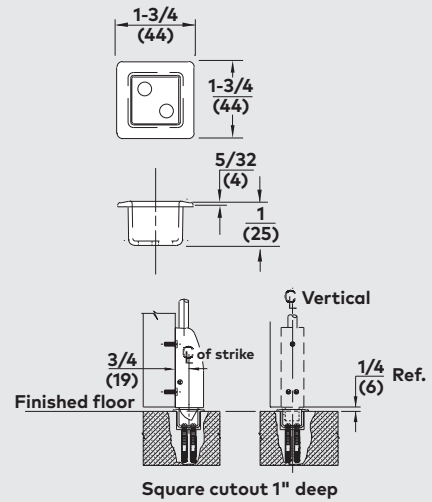

8400 strikes & minimum stile

No. 416V (optional)

Used with optional pullman type latch bolt.

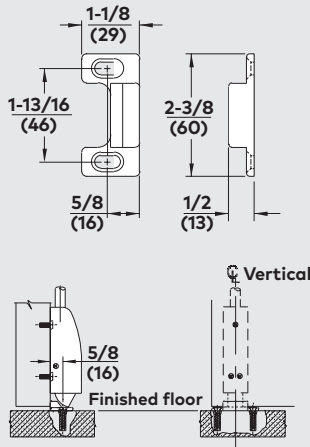

No. 426A (optional)

For flush door and frame conditions.

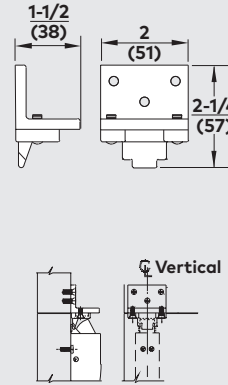

Minimum stile & vertical reference

Vertical Rod x Vertical Rod

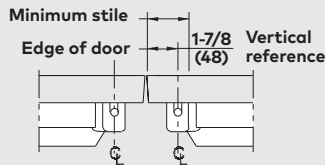

| Trim | *Minimum stile |
|-------------------|----------------|
| No trim, 8P02 | 3-3/16 (97) |
| 8PDT, 8P03 | 3-3/16 (97) |
| 8ODT, 8O03, 8O03P | 4-5/16 (110) |
| 8x, 8Hx | 4-1/4 (108) |

Vertical Rod x Rim

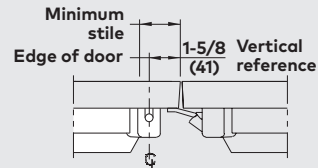

Not fire rated

| Trim | *Minimum stile |
|-------------------|----------------|
| No trim, 8P02 | 4-1/16 (103) |
| 8PDT, 8P03 | 4-1/16 (103) |
| 8ODT, 8O03, 8O03P | 4-1/16 (103) |
| 8x, 8Hx | 4 (102) |

*Minimum stile dimensions accommodate standard device touchbar widths shown. For smaller stiles, consult factory for optional touchbar lengths.

Note: Where x appears above, x = lever style. See page 13 for details.

Ordering guide

How to order 8000 Series trim

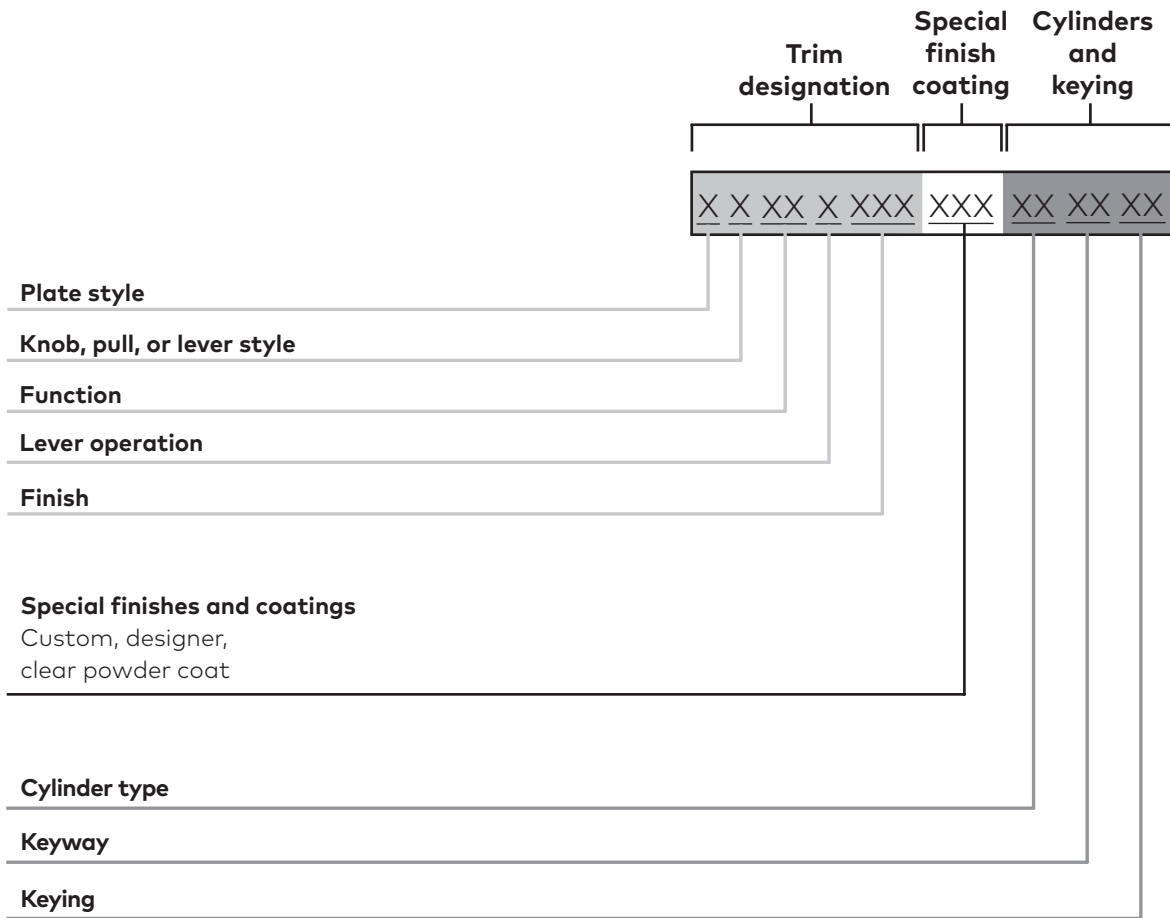

Patented key control

D100 is the keyway for DORMA's patented **SKC** serialized key control system. **SKC** is internet based and provides added layers of security. For more information, contact your local sales representative or Technical Service at 800-523-8483.

Lever & knob styles

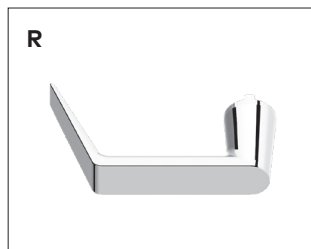
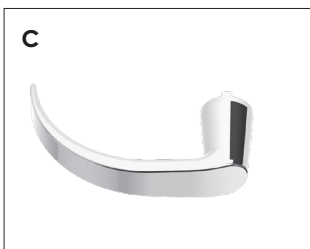

Wide plate/pull trim

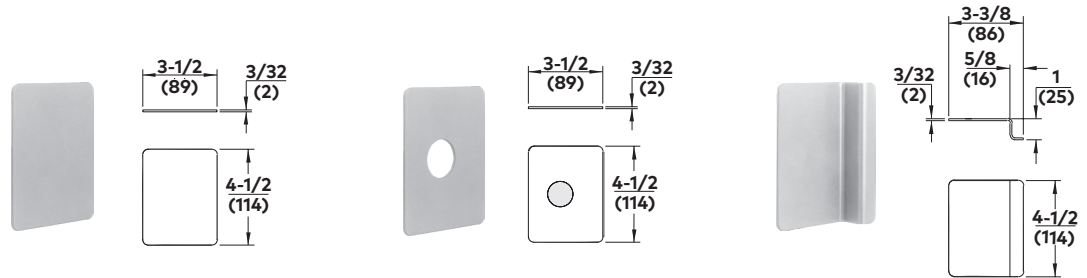

| Trim descriptions | Flat plate dummy trim | Flat plate with cylinder hole | Offset pull |
|------------------------------------|-----------------------|-------------------------------|-------------|
| Trim designation | 80DT | 8003 | 8PDT |
| Handing | — | — | — |
| Function | 02 | 03 | 02 |
| dormakaba cylinder (default) | — | 80R40SC – rim | — |
| dormakaba cylinder (optional SFIC) | — | 87R40BA – 7-pin | — |

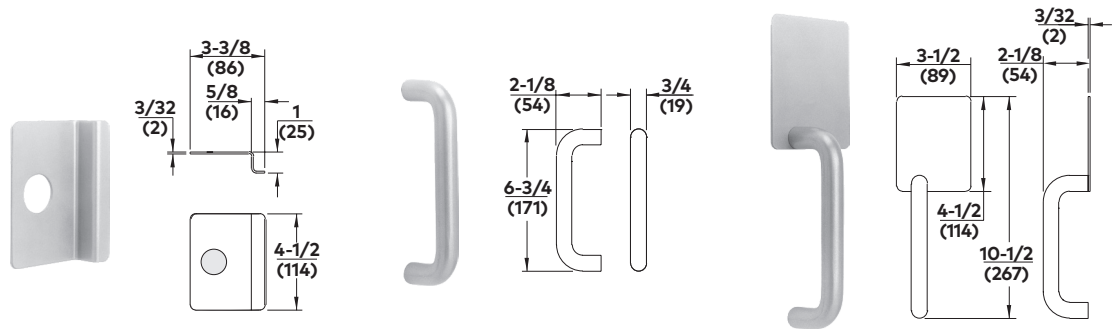

| Trim descriptions | Offset pull with cylinder hole | Tubular pull | Flat plate with tubular pull |
|------------------------------------|--------------------------------|--------------|------------------------------|
| Trim designation | 8P03 | 8P02 | 80DTP |
| Handing | — | — | Specify hand |
| Function | 03 | 02 or 03 | 02 |
| dormakaba cylinder (default) | 80R40SC – rim | — | — |
| dormakaba cylinder (optional SFIC) | 87R40BA – 7-pin | — | — |

Wide plate/pull trim

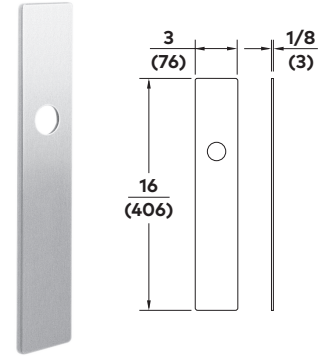
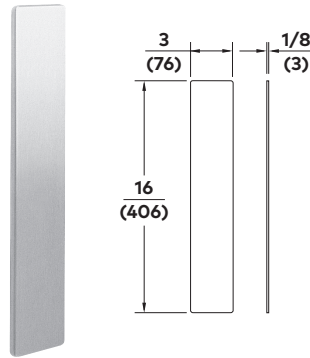
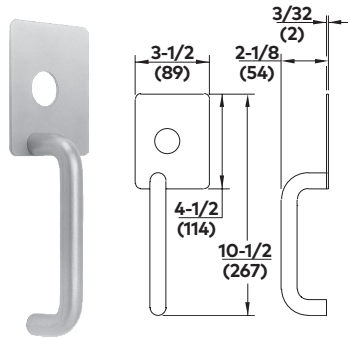

| Trim descriptions | Flat plate with tubular pull and cylinder hole | Wide flat plate dummy trim | Wide flat plate with cylinder hole |
|------------------------------------|--|----------------------------|------------------------------------|
| Trim designation | 8003P | NPSDT | NPS03 |
| Handing | Specify hand | — | — |
| Function | O3 | DT | O3 |
| dormakaba cylinder (default) | 80R40SC – rim | — | 80R40SC – rim |
| dormakaba cylinder (optional SFIC) | 87R40BA – 7-pin | — | 87R40BA – 7-pin |

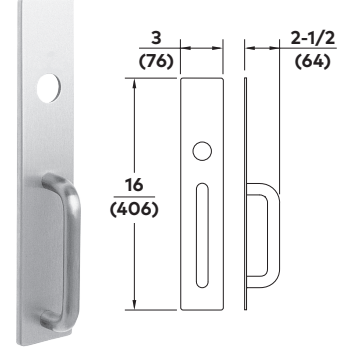
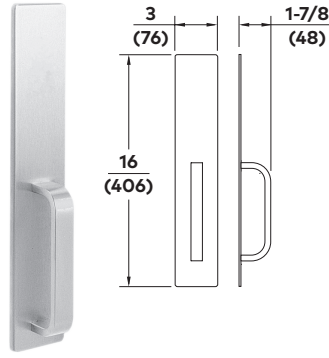
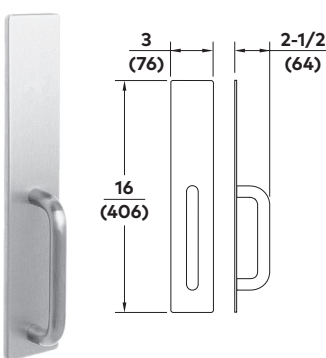

| Trim descriptions | Wide flat plate tubular pull | Wide flat plate rectangular pull | Wide flat plate rubular pull with cylinder hole |
|------------------------------------|------------------------------|----------------------------------|---|
| Trim designation | PTS02 | PRS02 | PTS03 |
| Handing | — | — | — |
| Function | O2 | O2 | O3 |
| dormakaba cylinder (default) | — | — | 80R40SC – rim |
| dormakaba cylinder (optional SFIC) | — | — | 87R40BA – 7-pin |

Pull trim

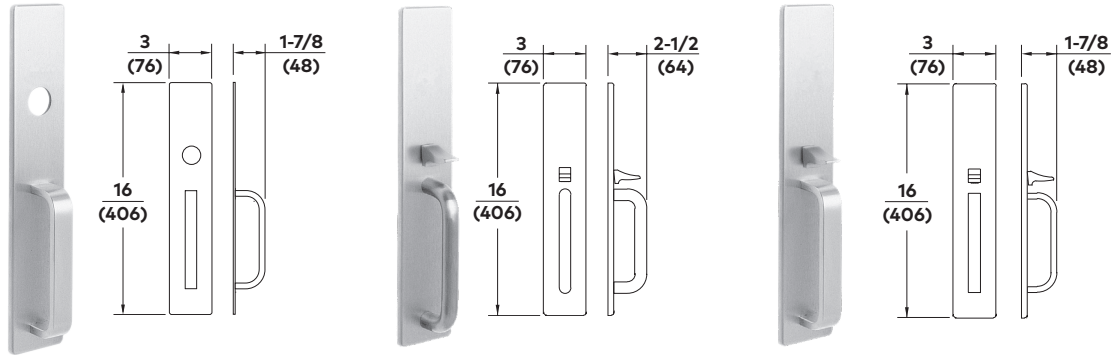

| Trim descriptions | Wide flat plate rectangular pull with cylinder hole | Wide flat plate tubular pull with thumbpiece | Wide flat plate rectangular pull with thumbpiece |
|------------------------------------|---|--|--|
| Trim designation | PRS03 | HTS22 | HRS22 |
| Handing | — | — | — |
| Function | O3 | 22 | 22 |
| dormakaba cylinder (default) | 80R40SC – rim | — | — |
| dormakaba cylinder (optional SFIC) | 87R40BA – 7-pin | — | — |

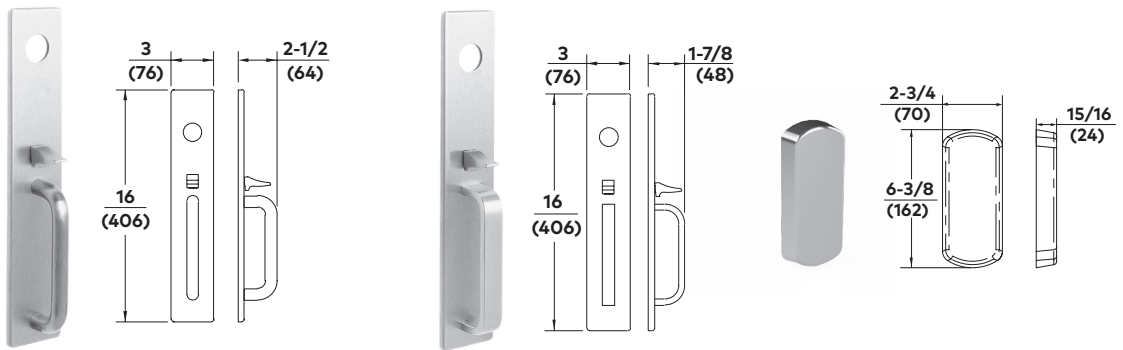

| Trim descriptions | Wide flat plate tubular pull with thumbpiece and cylinder hole | Wide flat plate rectangular pull with thumbpiece and cylinder hole | Raised escutcheon plate dummy trim |
|------------------------------------|--|--|------------------------------------|
| Trim designation | HTS05, HTS06 | HRS05, HRS06 | 8HDT |
| Handing | — | — | — |
| Function | O5 or O6 | O5 or O6 | — |
| dormakaba cylinder (default) | 90X10SC118 – mortise | 90X10SC118 – mortise | — |
| dormakaba cylinder (optional SFIC) | 97A10BA138 – 7-pin | 97A10BA138 – 7-pin | — |

Escutcheon trim

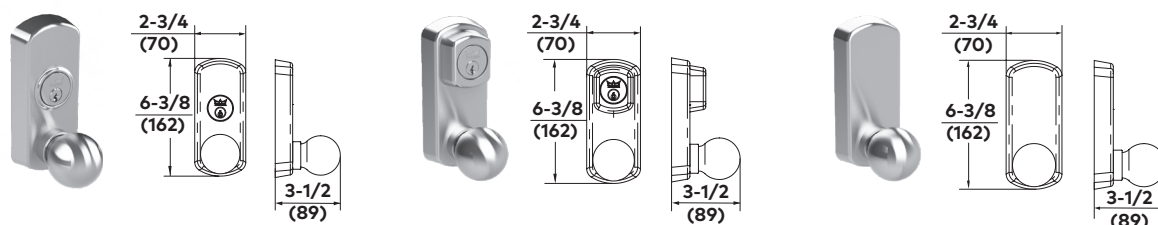

| Trim descriptions | Raised escutcheon plate knob with rim cylinder | Raised escutcheon plate knob with mortise cylinder | Raised escutcheon plate knob |
|------------------------------------|--|--|------------------------------|
| Trim designation | 8HK03 | 8HK08, 8HK09 | 8HK23 |
| Handing | — | — | — |
| Function | 03 | 08 or 09 | 23 |
| dormakaba cylinder (default) | 80R40SC – rim | 90X10SC118 – mortise | — |
| dormakaba cylinder (optional SFIC) | 87R40BA – 7-pin | 97A10BA138 – 7-pin | — |

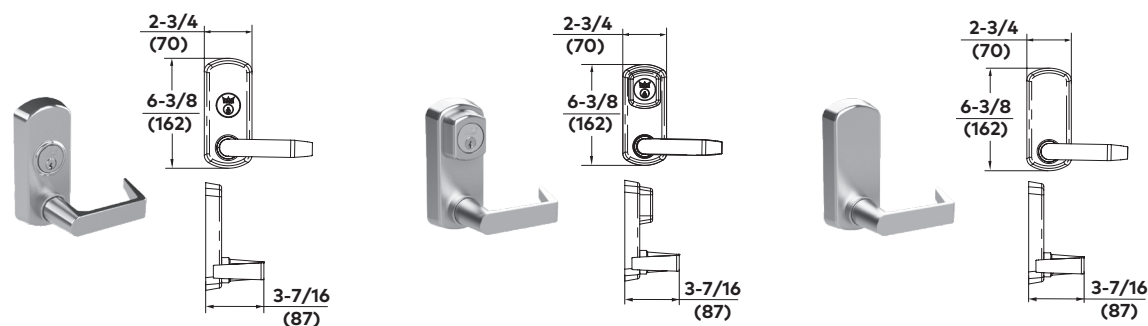

| Trim descriptions | Raised escutcheon plate lever with rim cylinder (R trim shown) | Raised escutcheon plate lever with mortise cylinder (R trim shown) | Raised escutcheon plate lever (R trim shown) |
|------------------------------------|--|--|--|
| Trim designation | 8Hx03 | 8Hx08, 8Hx09 | 8Hx23 |
| Handing | — | — | — |
| Function | 03 | 08 or 09 | 23 |
| dormakaba cylinder (default) | 80R40SC – rim | 90X10SC118 – mortise | — |
| dormakaba cylinder (optional SFIC) | 87R40BA – 7-pin | 97A10BA138 – 7-pin | — |

Sectional trim

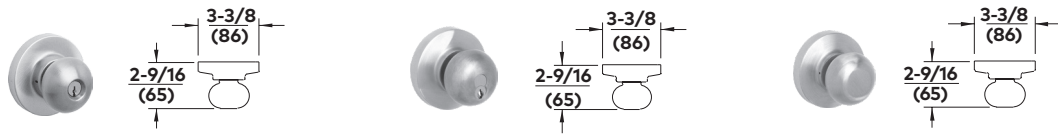

| Trim descriptions | Key-in knob | Key-in knob interchangeable core | Knob |
|------------------------------------|---|----------------------------------|------|
| Trim designation | 8K03, 8K08 | 8K03J, 8K08J | 8K23 |
| Handing | — | — | — |
| Function | O3 or O8 | O3 or O8 | 23 |
| dormakaba cylinder (default) | Includes key-in-knob cylinder 7013SC KD | Accepts SFIC | — |
| dormakaba cylinder (optional SFIC) | — | 77BAxxx – 7-pin | — |

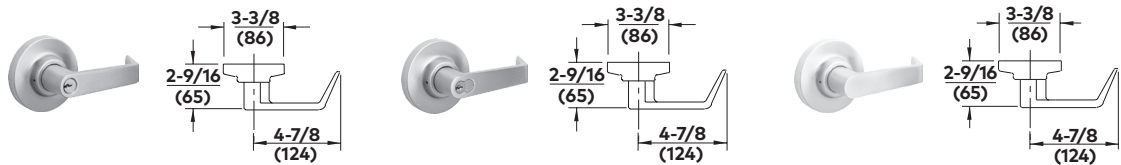

| Trim descriptions | Key-in rectangular lever | Key-in rectangular lever interchangeable core | Rectangular lever |
|------------------------------------|--|---|-------------------|
| Trim designation | 8R03, 8R08 | 8R03J, 8R08J | 8R02R, 8R23 |
| Handing | — | — | — |
| Function | O3 or O8 | O3 or O8 | O2 or 23 |
| dormakaba cylinder (default) | Includes key-in-lever cylinder 7013SC KD | Accepts SFIC | — |
| dormakaba cylinder (optional SFIC) | — | 77BAxxx – 7-pin | — |

Sectional trim

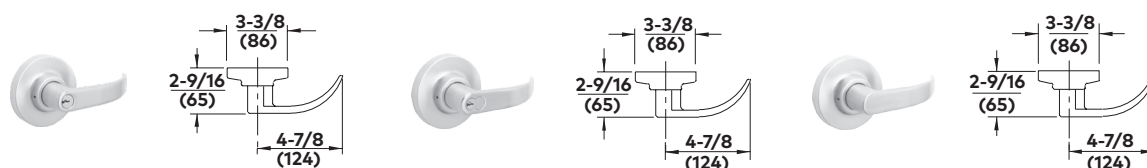

| Trim descriptions | Key-in curved lever | Key-in curved lever interchangeable core | Curved lever |
|---|--|--|--------------|
| Trim designation | 8C03, 8C08 | 8C03J, 8C08J | 8C02R, 8C23 |
| Handing | — | — | — |
| Function | 03 or 08 | 03 or 08 | 02 or 23 |
| dormakaba cylinder (default) | Includes key-in-lever cylinder 7013SC KD | Accepts SFIC | — |
| dormakaba cylinder (optional SFIC) | — | 77BAxxx – 7-pin | — |

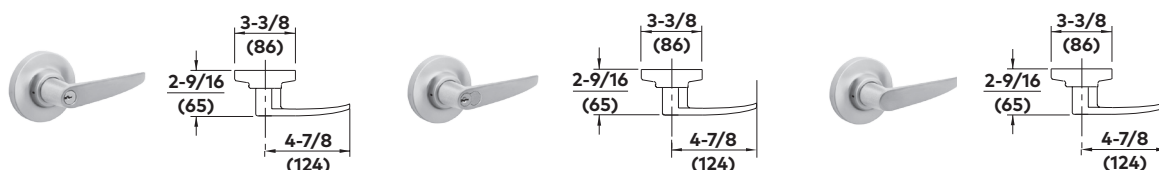

| Trim descriptions | Key-in straight lever | Key-in straight lever interchangeable core | Straight lever |
|---|--|--|----------------|
| Trim designation | 8G03, 8G08 | 8G03J, 8G08J | 8G02R, 8G23 |
| Handing | — | — | — |
| Function | 03 or 08 | 03 or 08 | 02 or 23 |
| dormakaba cylinder (default) | Includes key-in-lever cylinder 7013SC KD | Accepts SFIC | — |
| dormakaba cylinder (optional SFIC) | — | — | — |

Cylinder specifications

Rim cylinders

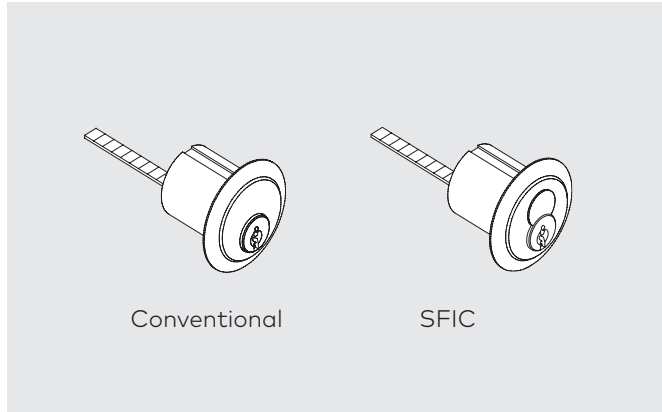

Mortise cylinders

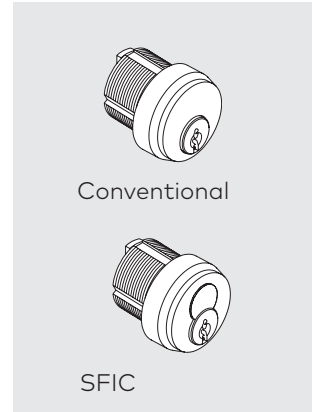

Key-in-lever cylinders

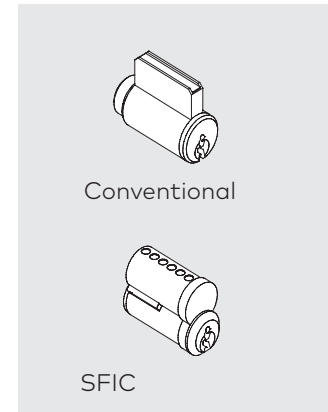

| Application | ANSI function | Cylinder type | Conventional (default) | SFIC 7-Pin |
|---|---------------|---------------|------------------------|------------|
| Cylinders for 8300/F8300 rim and 8400/F8400 surface vertical rod devices | | | | |
| Sectional trim (key-in-lever) | 03, 08 | Key-in-lever | 7013SC | 77BA |
| Wide plate trim | 03 | Rim | 80R40SC | 87R40BA |
| Wide plate trim | 05, 06 | Mortise | 90X10SC118 | 97C10BA138 |
| Pulls | 03 | Rim | 80R40SC | 87R40BA |
| Cylinders for device options | | | | |
| CD, BPA, BPAR | | Mortise | 90X10SC118 | 97D10BA138 |
| Cylinders for mullions | | | | |
| 134OKR key removable mullion | | Mortise | 90X01SC118 | 97D01BA138 |
| 134OSK mullion storage kit | | Mortise | 90X01SC118 | 97D01BA138 |

| Keyways | |
|---------|-------------|
| AA | Arrow A |
| CA | Corbin 60 |
| CB | Corbin 67 |
| CC | Corbin 77 |
| CD | Corbin 59A1 |
| CE | Cor Russ L4 |
| D100 | DORMA SKC |
| GA | Sargent LA |
| RA | Russwin 981 |
| RB | Russwin D1 |
| SC | Schlage C |
| SE | Schlage E |
| SF | Schlage F |
| YA | Yale 8 |
| YG | Yale GA |

Accessories

GK8000

Glass lite shim kit

Kit contains two 1/8" thick shims. Permits shimming of the exit device maximum 1/4" off door face without affecting U.L. listing. Designed to accommodate glass lite installed in door. Furnished bright zinc plated. Optional finishes available, consult factory.

Sex nuts

The information below serves as a simple reference when specifying 8000 Series exit devices and trim (two per pack).

| | |
|--------------------|---------|
| 8300/F8300 | 3 pack |
| 8300/F8300 w/ trim | 1 pack |
| 8400/F8400 | 5 packs |
| 8400/F8400 w/ trim | 4 packs |

Optional electrical functions

Electric latch bolt retraction

Specify prefix **ES**. A solenoid concealed in the touchbar assembly provides instantaneous retraction of the latch bolt to allow access from the secure side of the door. Remote control can be accomplished with switching devices such as key switches and card readers that provide a normally open electrical contact. The solenoid is rated for continuous duty, 24 VDC, 5 AMP inrush for 350 milliseconds, .21 AMP holding current. **Requires ES100 power supply and ES105 power transfer.**

Monitor switch

Specify prefix **MS**. A reed switch in the touchbar assembly which provides local and/or remote notification when the touchbar is depressed. Switch is rated for 3 AMP @ 28 VDC.

Latch monitor

Specify prefix **LM**. A microswitch attached to the device chassis on rated and non-rated 8300, 8400 and 8400 LB. Provides local and/or remote notification of movement of the panic device rods and latch bolt without depressing the touchbar. The switch is a single pole, double throw switch, 0.5 AMP @ 28 VDC maximum.

ES100 power supply

The ES100 power supply is capable of powering and controlling (2) 8000 Series exit devices with the ES electric latch bolt retraction feature.

- Input: 120 volts
- Input circuit protection: 1.3 AMP fuse
- Output: 24 VDC, 6 AMP surge for 0.5 seconds, .65 AMP continuous, per zone
- Output circuit protection: 3 AMP Push to Reset circuit breaker

- Enclosure: 8" high x 8" wide x 4" deep NEMA 1 Type enclosure for indoor use with hinged cover and knock-outs

ES101 delay module

The ES101 optional time delay module for the ES100 Power supply delays the relatching of ES series exit devices and has field-adjustable range between 1 second and 60 minutes.

This is a fail-secure option that allows time to enter a door after using a card reader or key switch, or may be required when ES Series panic devices are used in conjunction with an automatic door operator.

ES103 relay module

The ES103 optional relay module is a double pole, double throw relay with screw terminal connections. This coil rating is .025 AMP @ 24 VDC. The contact rating is 2.0 AMP @ 30 VDC.

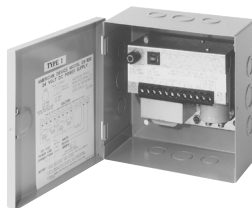

Relays may be wired in parallel if additional contacts are required. This relay may be required to signal other systems such as an automatic door operator.

Battery alarm exit device

The 8000 Series exit devices are available with an integral battery powered alarm. The 102 decibel alarm contained in the exit device touchbar and rail assembly activates when the touchbar is depressed and sounds continuously until the device is reset or the battery is completely discharged. Alternatively, a factory-furnished option allows the alarm to sound for four (4) minutes, then automatically rearms.

Furnished with and controlled by a lock cylinder and key, the unit allows ten (10) seconds to exit through the door after arming the alarm, indicated by an intermittently flashing red LED light in the touchbar. A yellow LED in the touchbar will flash, until manually reset by key, to indicate an unauthorized exit even if the alarm has automatically reset.

The unit is furnished with a 9 V, industrial-grade battery concealed in the end cap assembly for easy replacement. A tamperproof switch will activate the alarm if unauthorized removal of the battery is attempted. Option is available for 12 or 24 V direct power wiring.



- Specify prefix **BPA** to 8000 Series model number for battery alarm device.
- Specify prefix **BPAR** for 4 minute auto reset battery alarm device.
- Specify prefix **DWA** for direct hard-wired option.
- Size **A** device fits 48" wide door and can be cut to fit 34" wide doors.
- Size **B** device fits 36" wide door and can be cut to fit 28" wide doors.
- Size **C** device fits 36" wide door and can be cut to fit 22" wide doors.

Mullions

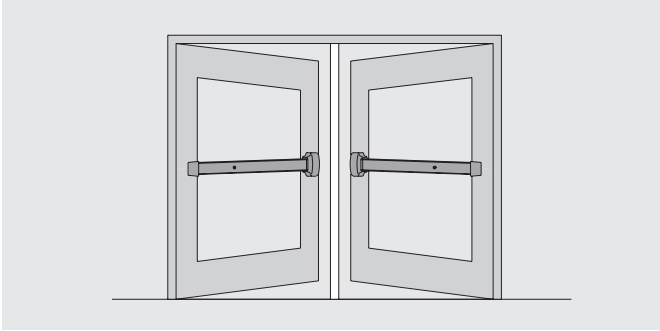

1310 aluminum mullion

- Meets demands of heaviest use areas.
- Durable extrusion.
- Supplied with wood/machine screws and anchors.

1310-8 – 8' mullion
1310-10 – 10' mullion
1310-8 x 443 – 8' mullion with recessed strike
1310-10 x 443 – 10' mullion with recessed strike

WS1310-8 – 8' mullion with weatherstrip
WS1310-10 – 10' mullion with weatherstrip
WS1310-8 x 443 – 8' mullion with weatherstrip and recessed strikes
WS1310-10 x 443 – 10' mullion with weatherstrip and recessed strikes

Finish
 Aluminum: 628 (satin)
 Bronze: 695 (dark)

1330 steel mullion

- Ideal for high-abuse areas such as schools.
- Meets demands of heaviest use areas.
- Heavy-gauge, smooth-surface steel construction.
- Attractive tube shape with rounded corners.

• Supplied with wood/machine screws and anchors.

1330-8 – 8' mullion
1330-10 – 10' mullion

Finish
 Prime: 600

F1300 steel mullion

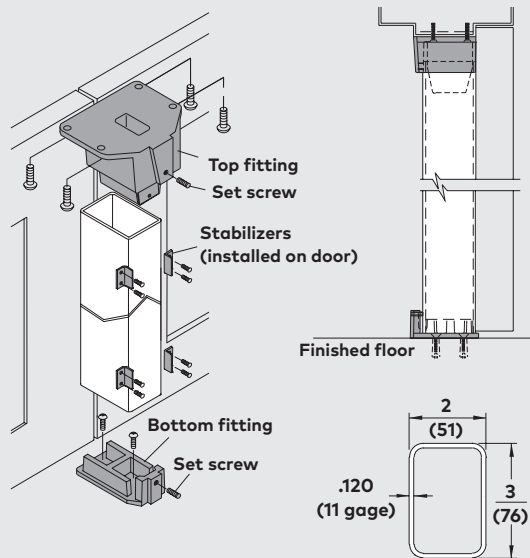

- For use with U.L. listed fire exit devices.
- Meets demands of heaviest use areas.
- Large top and bottom fittings for extra strength.
- Heavy-duty tube with rounded corners.
- Standard 8' length.
- Supplied with wood/machine screws and anchors.

F1300-8 — 8' fire-rated mullion

1300-8 — 8' non-fire-rated mullion

1300-10 — 10' non-fire-rated mullion

Finish

Prime: 600

F1340KR key removable steel mullion

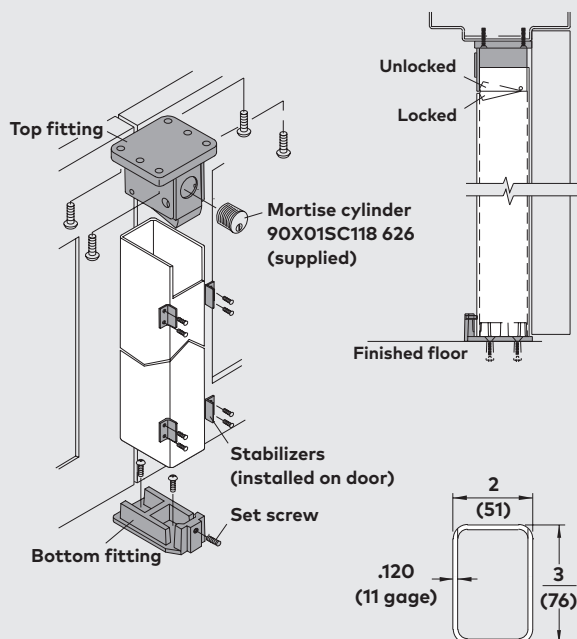

- Easily removable with key.
- Keying is standard 1-1/8" mortise cylinder with 01 (AR) cam.
- For use with U.L. listed fire exit devices.
- Meets demands of heaviest use areas.
- Large top and bottom fittings for extra strength.
- Heavy-duty tube with rounded corners.
- Standard 8' length.
- Supplied with wood/machine screws and anchors.

1340KREL-8 — 8' non-fire-rated wired key removable mullion

1340KREL-10 — 10' non-fire-rated wired key removable mullion

Finish

Prime: 600

Optional SFIC

97D01BA138 – 7-pin

1340SK Mullion Storage Kit

- For use with 1340 mullion.
- Locking cylinder can be keyed into master key system.
- Includes conventional default mortise cylinder: 90X01SC118 626.

F1340KR-8 — 8' fire-rated key removable mullion

1340KR-8 — 8' non-fire-rated key removable mullion

1340KR-10 — 10' non-fire-rated key removable mullion

Optional SFIC

97D01BA138 – 7-pin

DORMA USA, Inc.
Dorma Drive, Drawer AC
Reamstown, PA 17567
Tel: 800 523 8483
Fax: 800 274 9724
archdw.usa@dorma.com

DORMA Canada
1680 Courtney Park Drive, Unit 13
Mississauga, Ontario L5T 1R4
Tel: 800 387 4938
Fax: 905 670 5850
orders.canada@dormakaba.com

DORMA Mexico
Calle Sur 110 no. 63, Col. Tolteca
01150 México, D.F.
Tel: 5255 5272 6937
Fax: 5255 5272 6948

www.dormakaba.us

