

## Door Manual

# DORMA Dead Bolt Handle DG100DB-D Series For All Glass Door

### Contents of this Manual:

**DOOR FABRICATION (Dead Bolt Handle Installation) - Page 2**  
Handle Removal from Packaging  
Installation of Handle to Door

**DOOR INSTALLATION, Page 10**  
Header Preparation for Dead Bolt Engagement  
Bolt Adjustment for Proper Engaging With the Strike

**HANDLE CARE AND MAINTENANCE, Page 12**  
Care and Cleaning  
Stainless Steel Mirror Polished and Satin (Brushed) Finish  
Brass/Bronze Mirror Polish and Satin Finish  
Oil Rubbed Bronze  
Routine Maintenance  
Repair and Replacement (Replacing Lock Cylinder)

**IMPORTANT: PLEASE READ BEFORE INSTALLING THE HANDLE**  
The following instructions will reduce your chances of experiencing problems during installation, and ensure smooth, trouble-free operation of the handle.

# **DOOR FABRICATION**

## **(Dead Bolt Handle Installation)**

### **Introduction**

Congratulations on your selection of the DORMA Dead Bolt Handle DG1000DB-D. The DORMA system is designed to allow maximum view and a contemporary look to your all glass doors. The DORMA system meets the requirements of ANSI/BHMA A156.16 Grade 1.

By following the instructions in this manual, we believe you will experience a trouble free installation of the system.

Should you have any question about this system or any other DORMA products, please contact us at (800) 523-8483 or visit our website at [www.dorma-usa.com](http://www.dorma-usa.com).

### **Tools and Supplies needed:**

- 1set - DORMA supplied hex wrenches
- 1 ea - 10" Non-Marring Channel Lock Pliers (optional)
- 1 ea - DORMA supplied Thread Locker
- 1 ea - Rubber strip, i.e. 1/8" thick rubber setting block

## Removal from Packaging

The Handle comes mounted on the Mounting Board inside the wooden crate. To remove the handle from the board, please follow the step 1 through 4. ➔

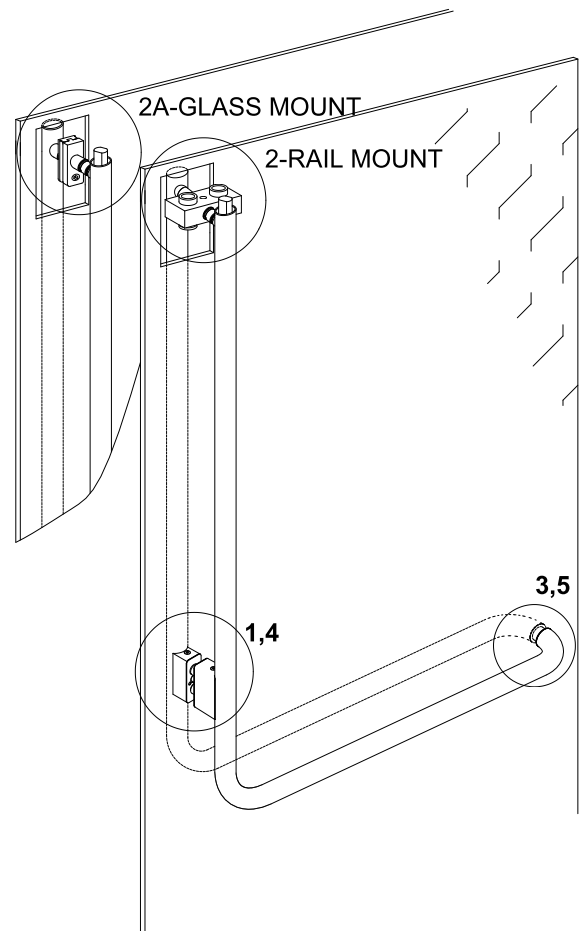

1. To remove the Handle from the board first loosen two flat head socket screws (A) so they protrude approximately 1/4" from Cylinder Housing (B) being careful NOT TO REMOVE them. Push or tap screws flush (C).

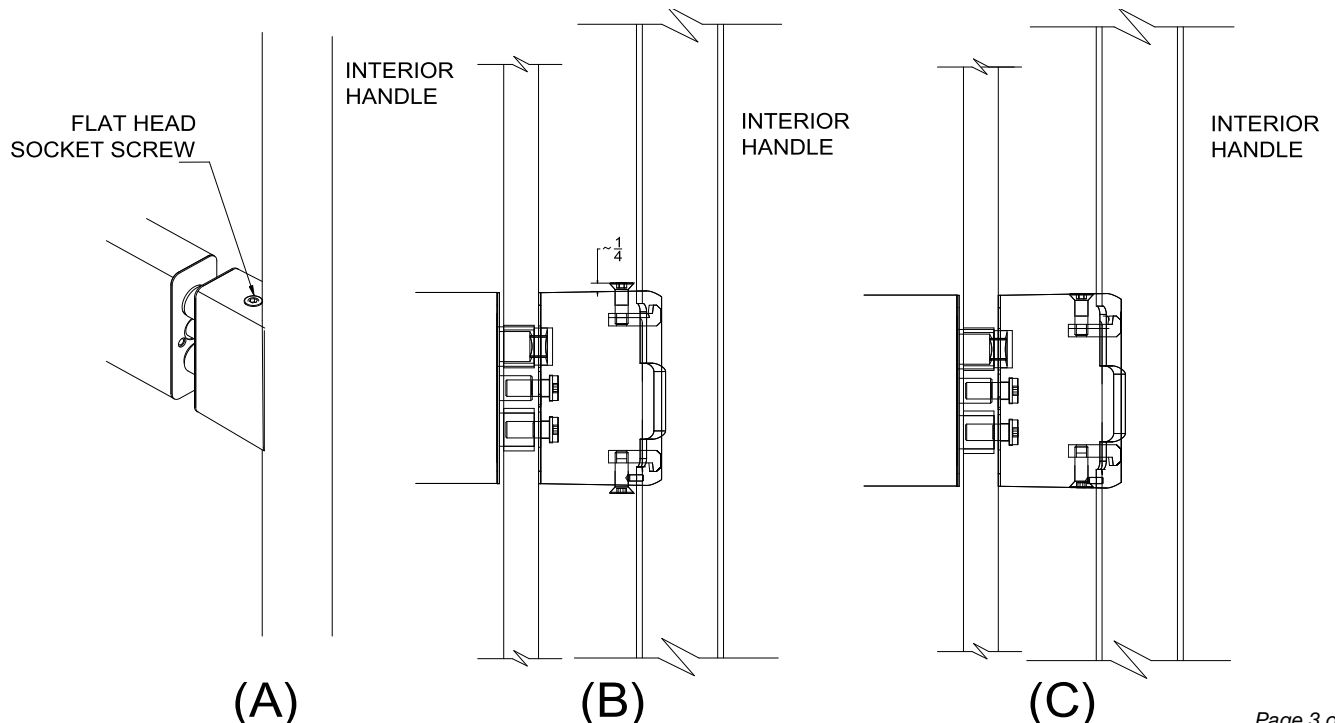

2. FOR RAIL MOUNT HANDLE. Rotate round connector pivot fitting counter clockwise and remove from Adapter Block. Note: Use pliers and rubber strip (to protect finish) for removal of round connector. Remove the Exterior Handle Screw to release the exterior handle from the adapter block.

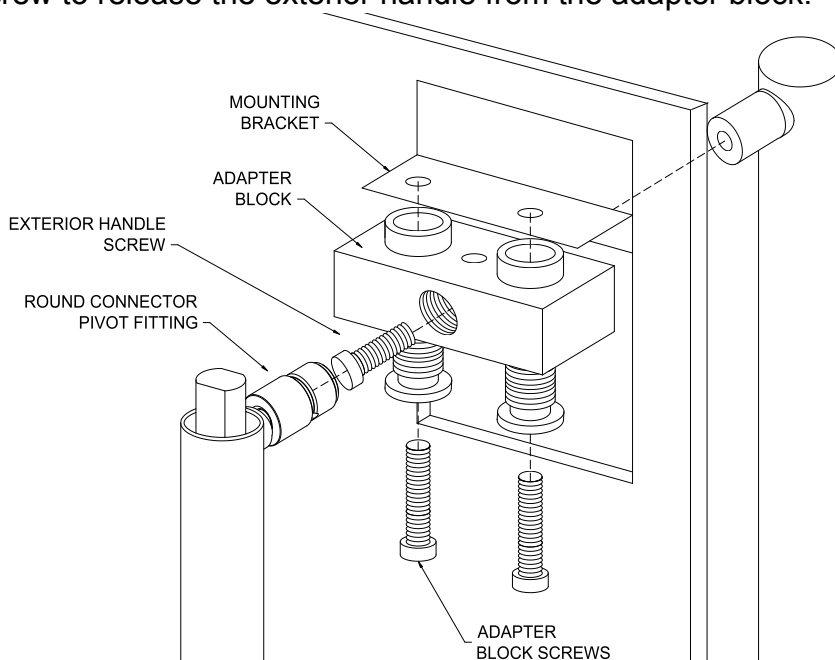

- 2.A. FOR GLASS MOUNT HANDLE. Remove Socket Head Cap Screw from Interior Pivot Bracket and Exterior Bracket. Be careful not to lose Gaskets located between Interior and Exterior Brackets

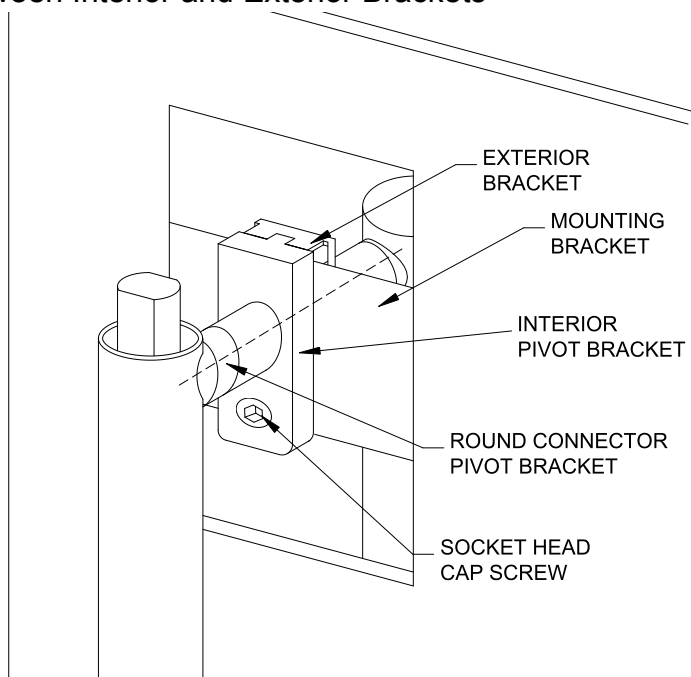

3. Remove threaded pin from bottom of horizontal handle and pull horizontal handle away from plywood. ➡

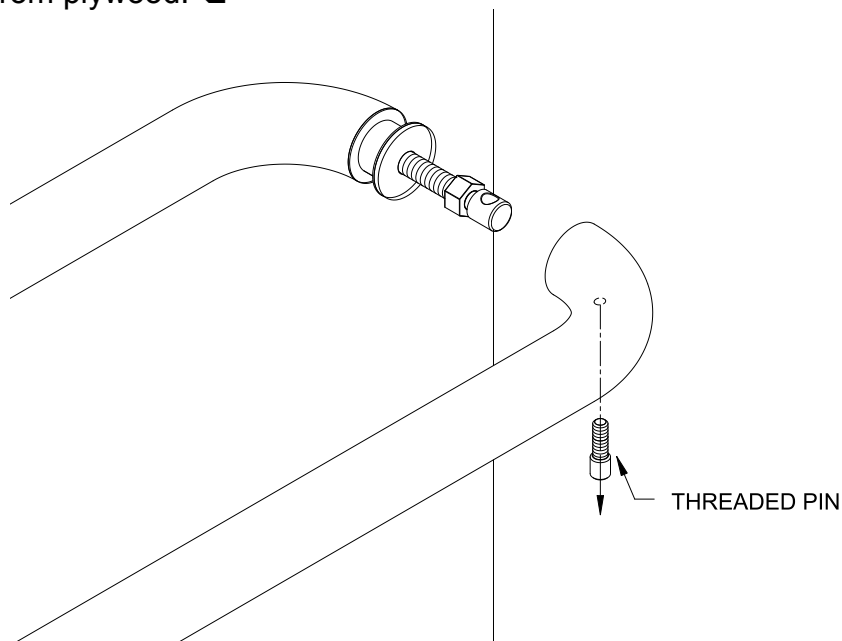

4. Remove 2 cap screws from the inside of the Cylinder Housing, and remove the housing from the board. Support and remove exterior cylinder housing, rubber bushings and spacer sleeve and save it for re-use during installation to the door. ➡

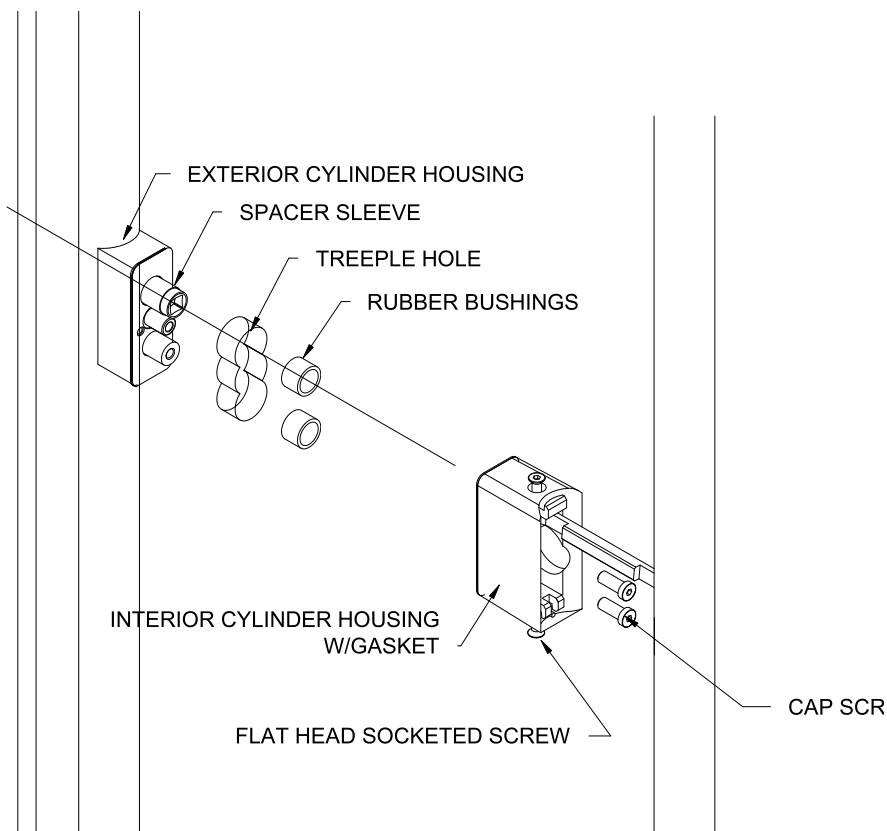

5. Back off locking nut and unwind the stud, being careful that the handle does not fall from the backside of the plywood. Remove rubber bushing for re-use during installation to the door.

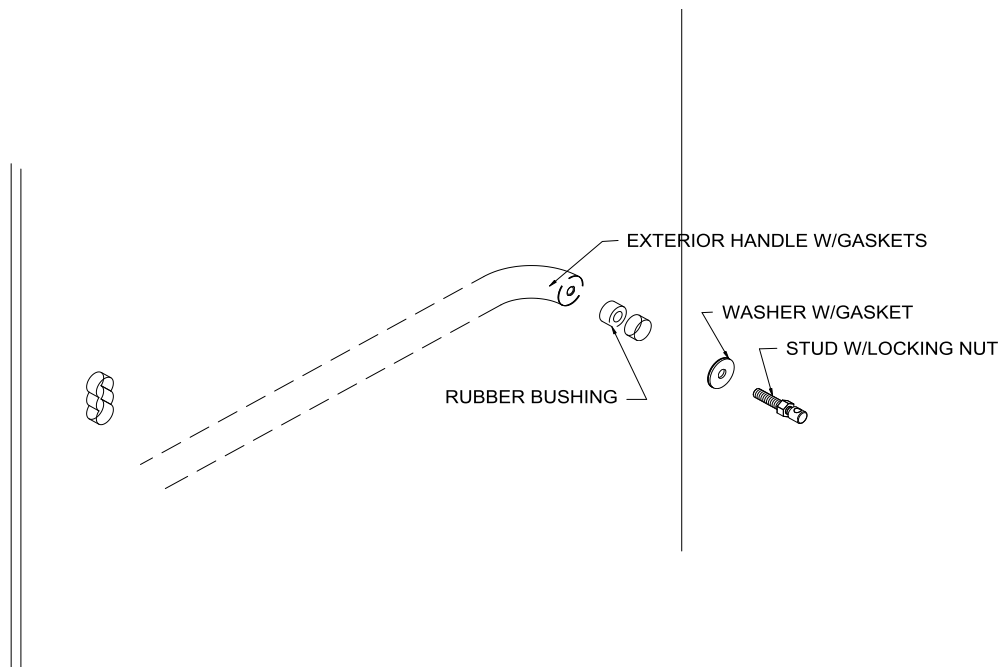

Apply **THREADLOCKER** to all fasteners used to mount handle on doors.



### Installation of Handle to Door:

- Lay glass flat with the exterior side facing down on a pair of saw horses.
- Attach Door Rails (if applicable) positioning the mounting hole in the rail at the inside face/strike edge of door. DORMA DRS Rail System Installation instructions attached.

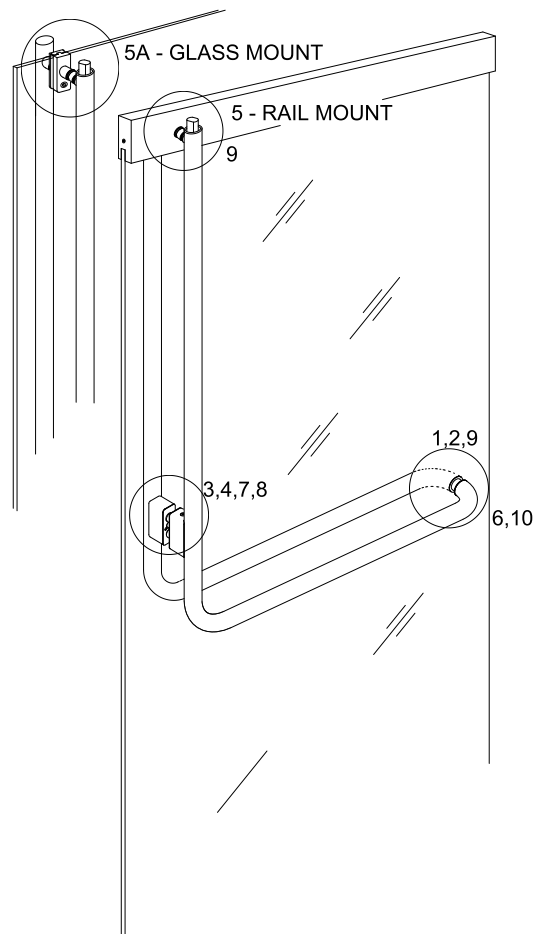

1. Insert rubber bushings into glass holes for exterior horizontal handle. Place handle in position on exterior side of glass and hand tighten retainer cap through rubber bushing into handle.
2. Install stud with locking nut through washer w/gasket and hand tighten. ↓

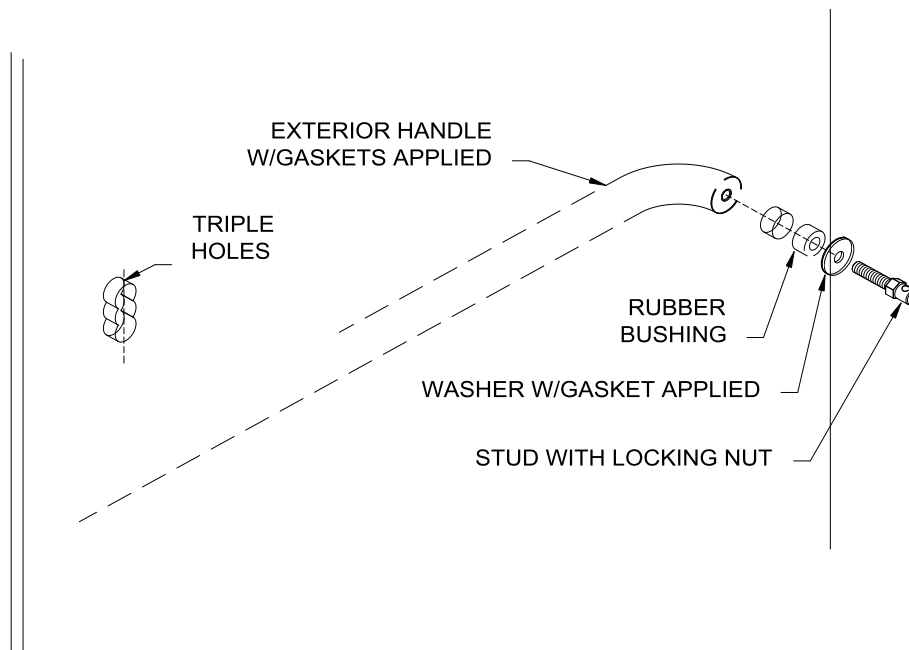

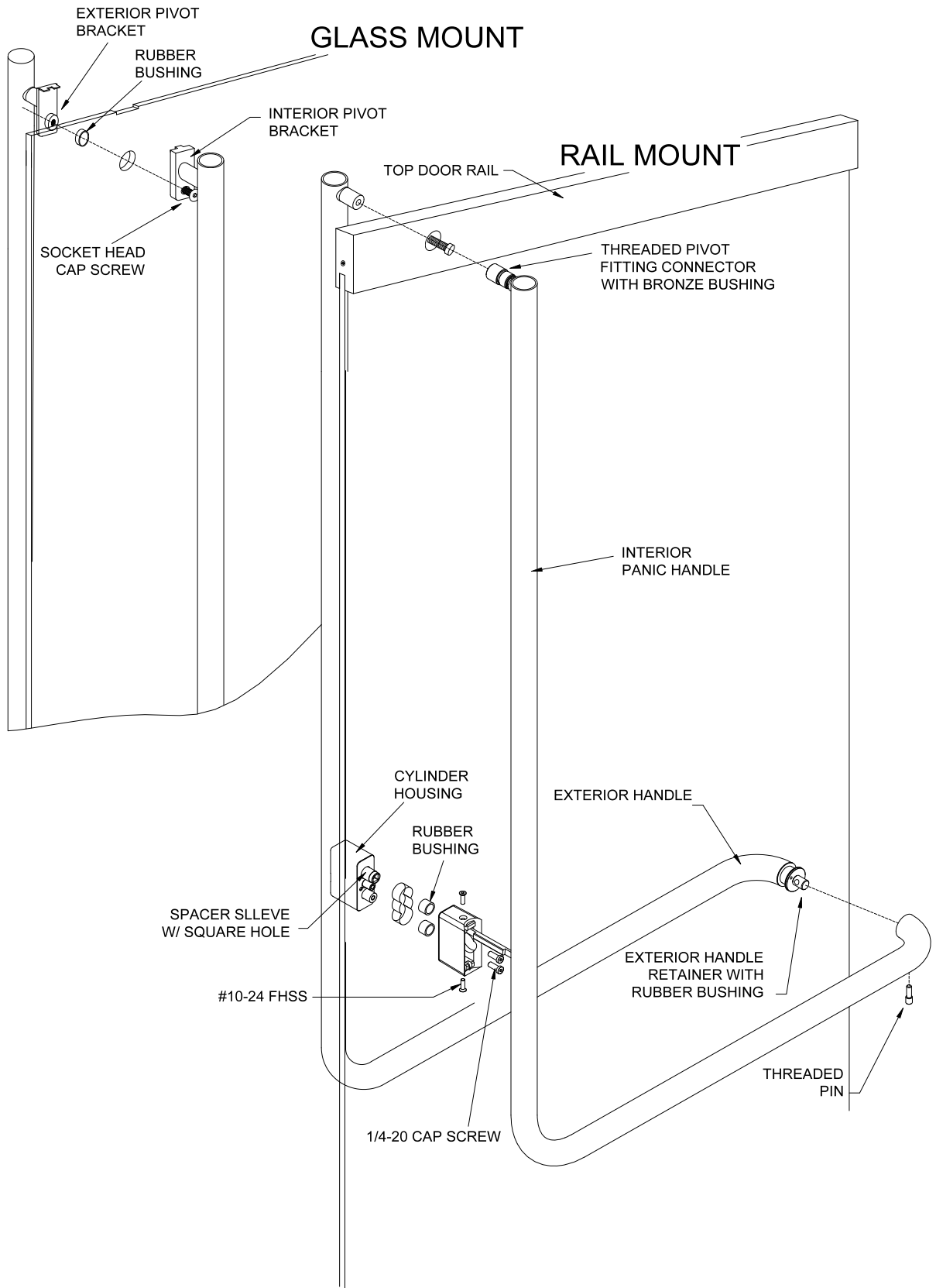



3. Install exterior lock housing with rubber bushing and spacer sleeve being careful that the square hole is facing the exterior handle with sides of hole in line with the handle width, and the lock cylinders in both housings are facing the hinge side of the doors. For installation of both housing together use two ¼-20 cap screws. Finger tight. Both gaskets on lock housings have to be applied.
4. Push two #10-24 FHSS flush with housing and place the interior handle on the door over pivoting end of exterior handle and pivoting end on the rail.
5. RAIL MOUNT HANDLE: Tighten the threaded pivot bracket connector to the adapter block at the top of the door.

Adapter block is mounted inside the top rail with two bolts using predrilled holes. Position/height of this block is adjustable for best alignment with the "bracket connector" hole on the rail.

*If experiencing difficulties aligning top pivot bracket connector with the hole on the rail, please refer to the DORMA*

*DRS Rails installation instructions for possible adjustments of the top rail.*

Wind the threaded pivot bracket connector to start thread.

- 6.A. GLASS MOUNT HANDLE. Insert rubber bushing into glass hole at top of glass door. Place exterior pivot bracket against exterior side into notched portion of glass. Align interior handle with exterior pivot bracket and tighten low head cap screw.
6. Install threaded pin by hand to start thread.
7. Check the alignment and gently remove the interior handle. Tighten ¼-20 set cap screws, interior cap and exterior handle stud with locking nut. Install handle and start thread at top and bottom pivot end.
8. Applying pressure on interior handle at inside cylinder housing evenly tighten #10-24 FHSS.
9. Tighten the threaded pivot bracket connector to the adapter block at the top of the door.
10. Insert threaded pin and tighten with hex wrench.  
Stand doors on the blocks and test lock functioning.

- **This completes the Panic Handle installation to the door. Please be careful not to lift the door with any portion of the Panic Handle.**
- **When handling the Door assembly, it is recommended to use Roller-Blocks for supporting the corner of the door rail while rolling into the vertical position. This will prevent damage to the end cap.**

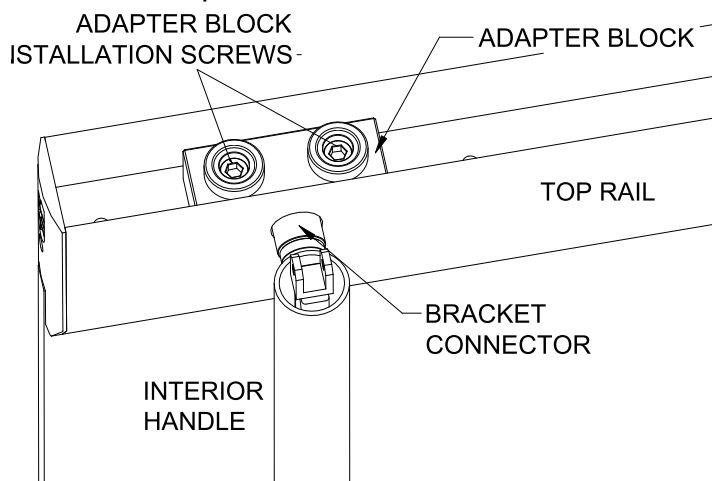

# DOOR INSTALLATION

## Header Preparation for Single and Double Door

Prepare Header with reinforced holes sized and located as illustrated:

### SINGLE DOOR

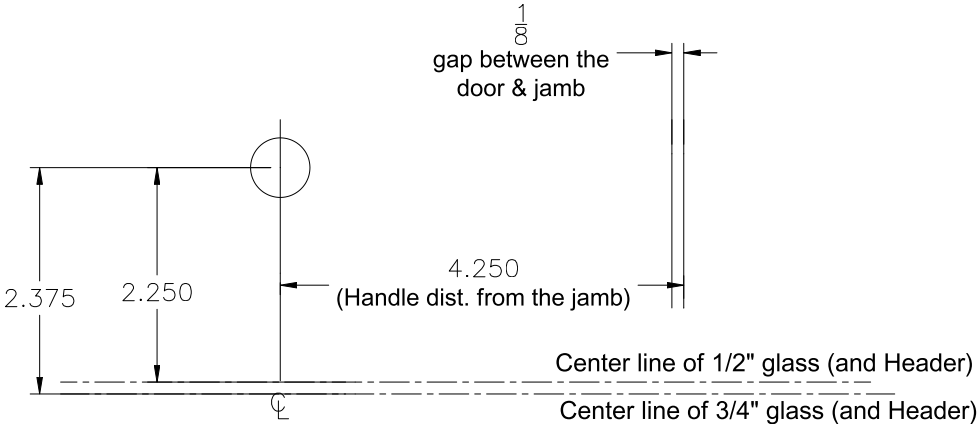

### DOUBLE DOOR

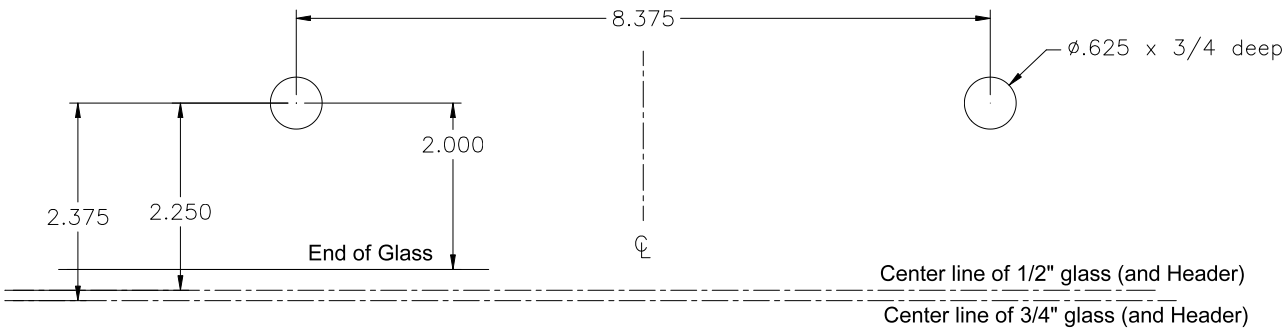

## Bolt Adjustment for Proper Engaging With the Strike

1. The retractable bolt can be adjusted up and down. The centerline of the pin at the top of the retractable bolt should penetrate the strike for a minimum 1/8". The maximum upward adjust is 3/4" measured from the top of the handle tubing to the top of the bolt.
2. To make this adjustment, with an hex wrench, remove the flat head screw at the top of Panic Handle. **DO NOT** Remove the Slotted Head Screw.
3. Rotate the bolt in either direction full 360° turn to obtain desired height adjustment.
4. Rotate bolt to align interior threaded hole with countersunk hole in tubing.
5. Replace flat head screw.

FAILURE TO REPLACE THIS SCREW WILL ALLOW RETRACTABLE BOLT TO RANDOMLY ROTATE CAUSING THE BOLT TO IMPROPERLY ENGAGE THE STRIKE.

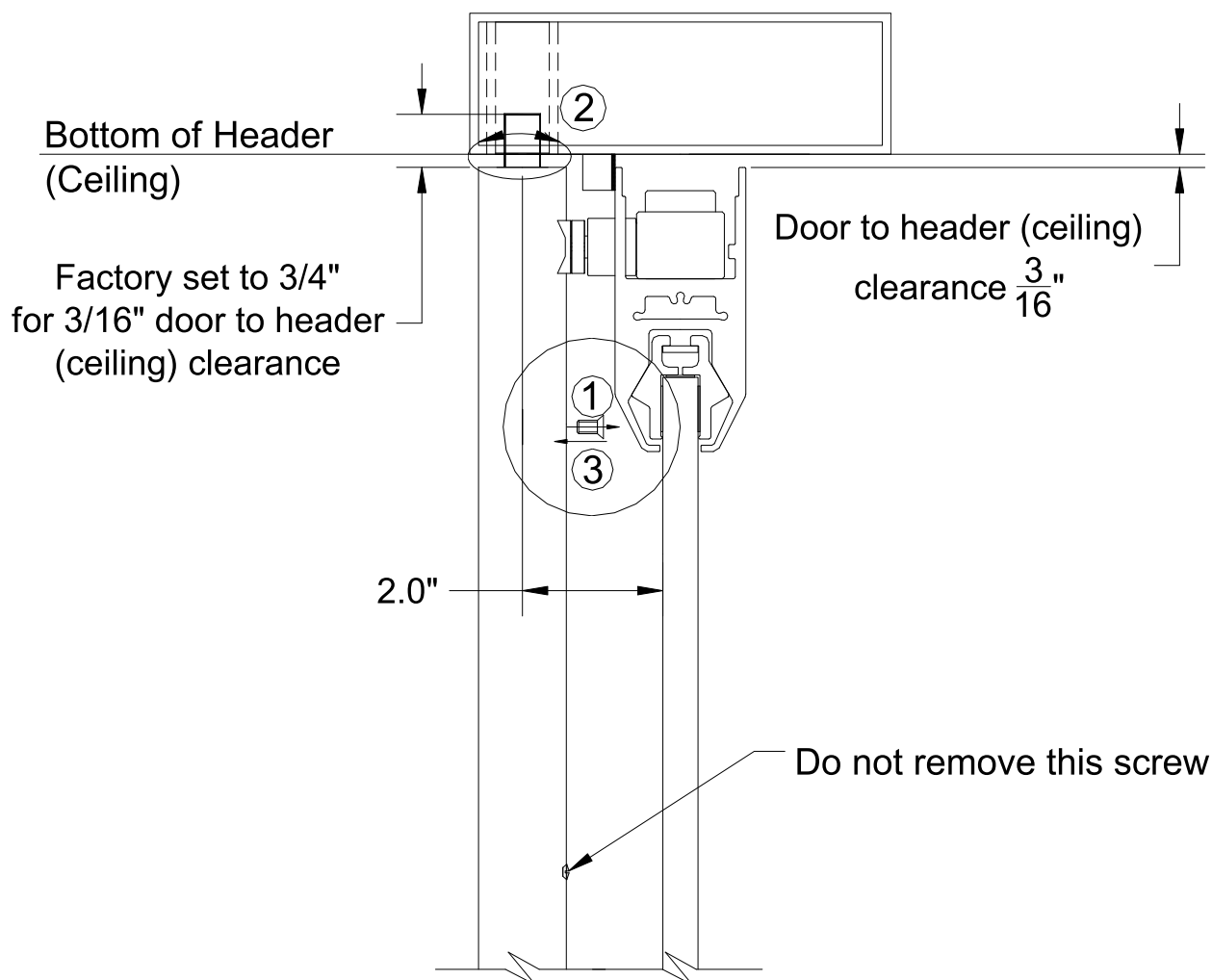

## HANDLE CARE AND MAINTENANCE

### Introduction

Congratulations on your selection of the DORMA Dead Bolt Handle System. The DORMA system is designed to allow maximum view and a contemporary look to your all glass doors. The DORMA system meets the requirements of ANSI/BHMA A156.16 Grade 1.

By following the instructions in this manual, we believe you will experience trouble free operation over the life of the system.

Should you have any question about this system or any other DORMA products, please contact us at (800) 523-8483 or visit our website at [www.dorma-usa.com](http://www.dorma-usa.com).

### Care and Cleaning

#### Stainless Steel

Mirror and Satin polished Stainless Steel are one of the most durable and easiest finishes to maintain.

#### Mirror Polished Stainless Steel:

Mirror polished stainless steel finishes should be cleaned with a foam spray cleaner.

**Do not** use circular motions when polishing.

### **Satin Polished Stainless Steel (Brushed):**

Satin polished stainless steel finishes should be cleaned like Mirror polished Stainless Steel, just **with** circular motions in the same direction as the grain texture.

For periodic maintenance, satin stainless steel can be rubbed with an abrasive pad.

[Scotch-Brite General Purpose Hand Pad 7447 by 3M](#), or

[Scotch-Brite Ultra Fine Hand Pad 7448 by 3M](#), or

[Scotch-Brite General Purpose Scrubbing Pad 9650 by 3M](#).

The finish should always be rubbed in the same direction as the grain texture.

### **BRASS / BRONZE**

Polished and Satin finish applied to brass or bronze must be routinely maintained to retain the desired appearance. The darkening or black spotting on the brass or bronze surface is simply oxidation taking place. If left untreated brass and bronze will eventually turn entirely, but unevenly, dark. This dark oxidized state is the natural color of all copper alloys.

Frequency of the treatment of brass and bronze finishes depends on use and abuse, location, weather conditions, or exposure to marine air.

DORMA does not recommend any protective coating over the brass or bronze finish. These coatings provide only temporarily reprieve from the eventual oxidation that will occur on any brass or bronze finish.

Lacquer finishes are susceptible to scratching and abrasion. Once the surface of the lacquer has been damaged, oxidation will take place. Oxidation of the brass or bronze will appear as black spots. Scratches in the lacquer coating cannot just be covered up or sprayed over. Repair requires the stripping of the lacquer from the entire part using solvents. Then the lacquer must be re-applied.

Brass and bronze are beautiful metals but require continual maintenance to retain its luster.

### **Mirror Polished Brass or Bronze**

Mirror polished copper alloys should be periodically cleaned, when it begins to tarnish, with a brass polishing cream that uses low-level abrasives. The liquid or cream polish should be used in accordance with the manufacturer's recommended instructions for safety and use. **Do not** use circular motions when polishing.

### **Satin Polished Brass or Bronze:**

Satin polished copper alloy finishes should be cleaned by rubbing with an abrasive pad.

[Scotch-Brite General Purpose Hand Pad 7447 by 3M](#), or

[Scotch-Brite Ultra Fine Hand Pad 7448 by 3M](#), or

[Scotch-Brite General Purpose Scrubbing Pad 9650 by 3M](#)

The finish should always be rubbed in the same direction as the grain texture.

### **Satin, Oxidized and Oil Rubbed Bronze:**

*Regularity is the key to a successful maintenance program. A schedule should be arranged providing periodic cleaning with regular inspections in the interim. The schedule should differentiate between interior and exterior surfaces and those surfaces subject to handling, scuffing and abrasion. When a regular maintenance program is followed, most installations can be maintained by oiling or waxing.*

Surfaces pre-finished or naturally weathered to the statuary bronze shades should be maintained by periodic oiling with Lemon Oil, Lemon Grass Oil or high-grade paraffin oil. Oil and wax coatings look best when applied with a well-impregnated, clean soft cloth followed by rubbing with a second, clean soft cloth to remove excess oil or wax.

*Frequency of oiling or waxing is as important as the oil or wax used. Newly installed metal should be oiled weekly for the first month in order to build up a protective film. Metals subject to heavy traffic should be oiled or waxed at one to two-week intervals. Where traffic is moderate to light, monthly treatment may suffice. In non-traffic areas, quarterly or semiannual applications are feasible.*

*Frequency could also be determined when the metal finish appears dull and dry.*

*The frequency of oiling will decrease over time as layers of oil build up to create a protective surface and result in what is known as oil rubbed bronze*

*Considering a typical building entrance, door handles, push plates or bars, and kick plates as well as the door stiles and rails, would normally be exposed to heavy traffic.*

*The doorframe and adjacent window wall framing usually receive less handling and would be considered a moderate to light traffic area. Transoms, canopies and similar metal elements normally out of reach would be classed as non-traffic areas.*

### **Finishes Coated with Clear Baked Enamel or Clear Enamel or Clear Lacquer:**

Finishes coated with a clear baked enamel, clear enamel or clear lacquer coating can be cleaned periodically by gently wiping with a mild soap and water solution, rinsed with clean water and wiped with a clean, dry cloth. No Brass cleaners or polish, no oil or abrasive cleaners or ammonia.

When fingerprints become visible, the coated metal should be wiped with a soft dry or damp cloth as soon as possible.

We do not recommend any protective lacquering of brass and bronze door hardware. Lacquer wears off in certain use areas leaving a non-uniform or spotty finish. The areas most affected are those where the handles contact the metal. Furthermore, rings worn on the fingers can cause the lacquer to be removed thus exposing the scratches of the lacquer.

However, protective lacquer will retard aging but not eliminate and will eventually have to be re-done. If proper maintenance is followed, you will be able to elongate the times between refinishing.

## Routine Maintenance

Under normal operating conditions, your DORMA Dead Bolt Handle should require no maintenance over the life of the system other than cleaning the bars. However, if you experience difficulty with the operation of the system, please **do not attempt to repair the system yourself**. Please contact the original installer or contact DORMA at (800) 523-8483.

## Repair and Replacements

### Replacing Cylinder

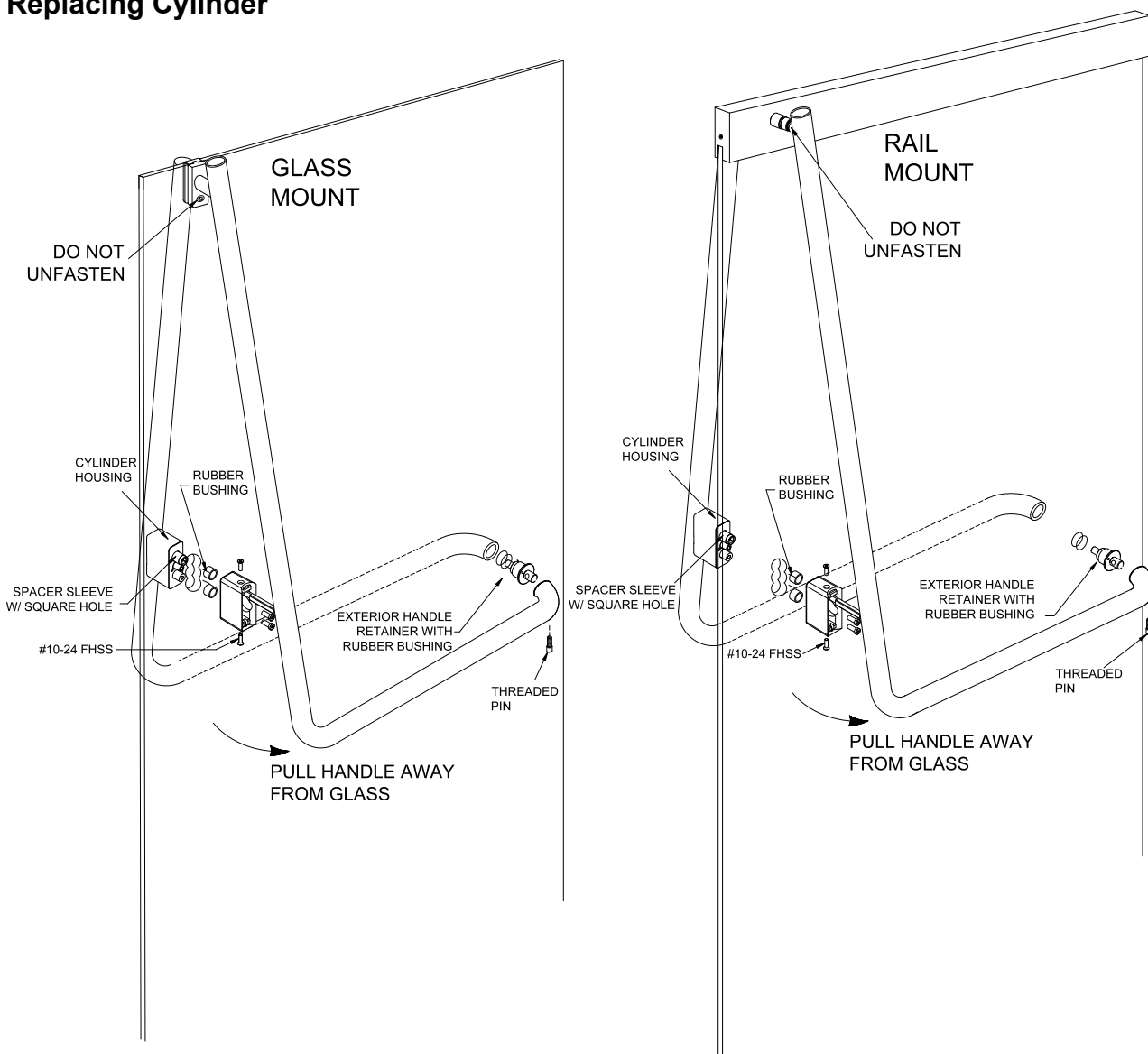



1. Loosen the flat head cap screws for approximately 1/8".
2. Push the screws with clamps back into the Lock Housing.

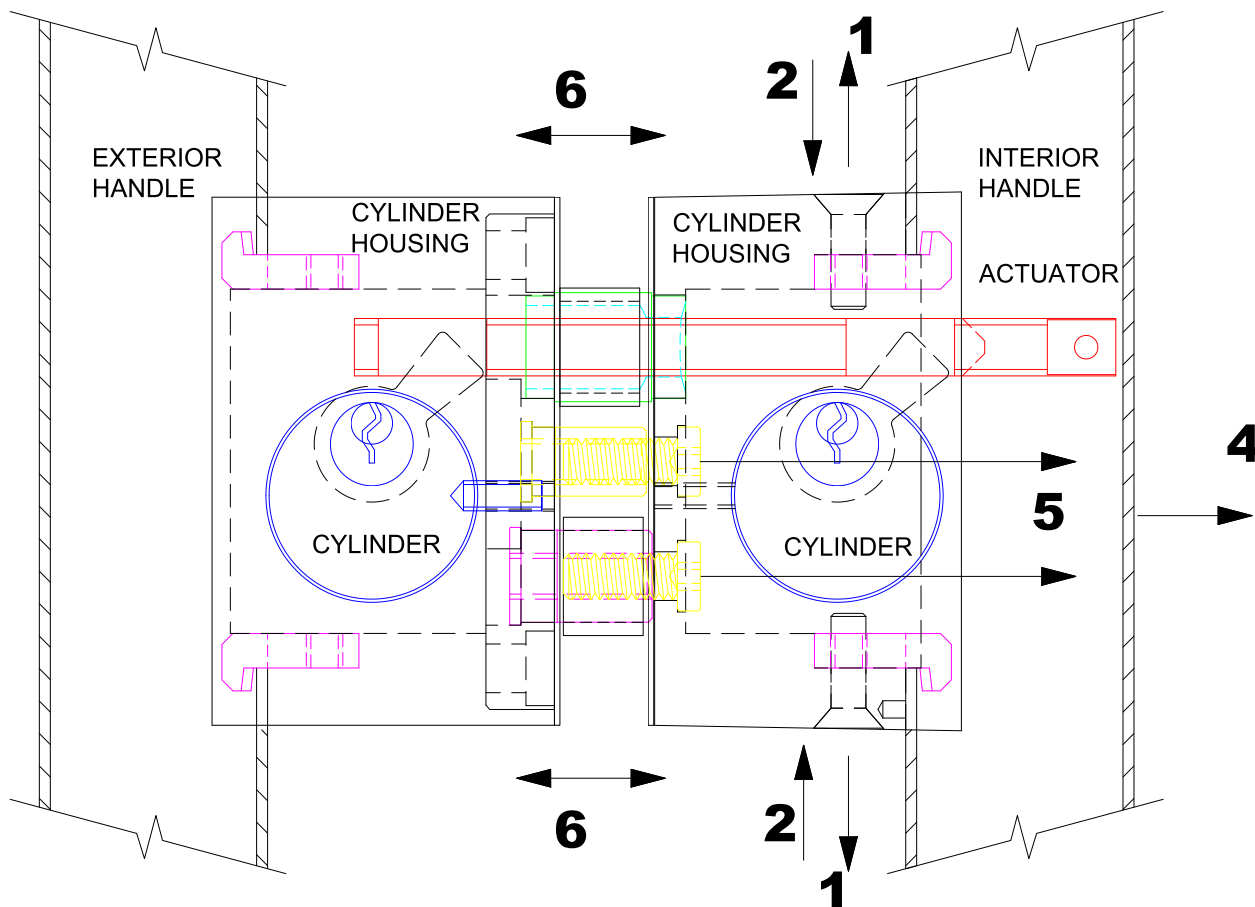

3. Remove the threaded pin from the bottom of the handle.
4. Move the Inside Handle form the Housing to make it possible to approach two inside screws with hex wrench.
5. Remove inside screws and hold Exterior Housing.
6. Remove both Housings from the glass.

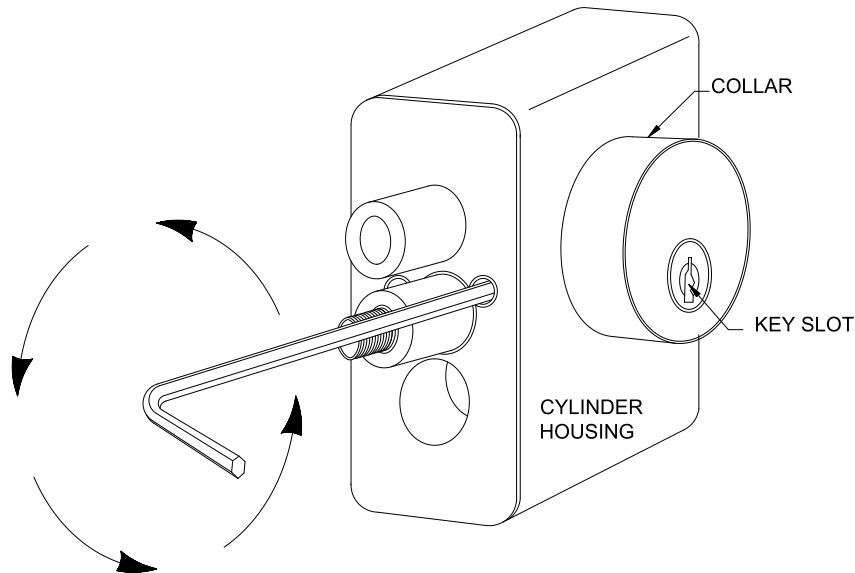

7. Remove old cylinder and check to see if tailpiece matches new cylinder tailpiece. Also the length of the new cylinder must be the same as the old one. A cylinder of any other length will require a new length collar. Wind in new cylinder until it stops inside the collar ring. Key slot should be on bottom of cylinder nearest the floor.
8. To reassemble system, Insert handle actuator into panic handle and place against door (reverse of step 3 on page 6).
9. Replace cylinder housing and attach to handle actuator with flat head socket cap screw (reverse of step 2 on page 6).

