

Überstandsmaße Griffstange an Teleskop

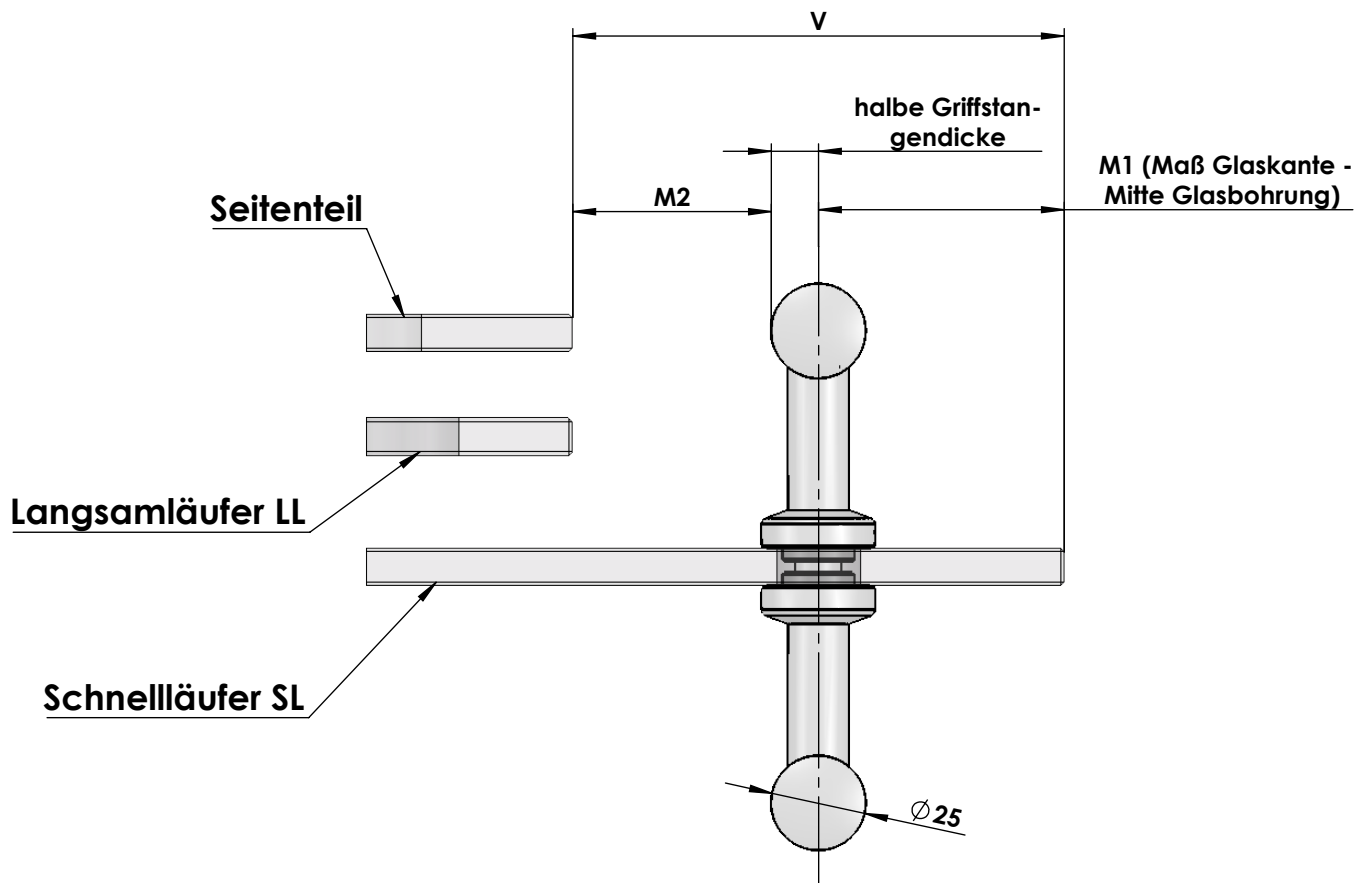

M1	Maß Glaskante - Mitte Glasbohrung
M2	Maß für Klemmfreiheit (empf. 37mm)

Beispiel für Maß V:

$$\begin{aligned} V &= M1 + \text{halbe Griffstangendicke} + M2 \\ V &= 80\text{mm} + 13\text{mm} + 37\text{mm} \\ V &= 130\text{mm} \end{aligned}$$

Supernumerary grip handle at telescope

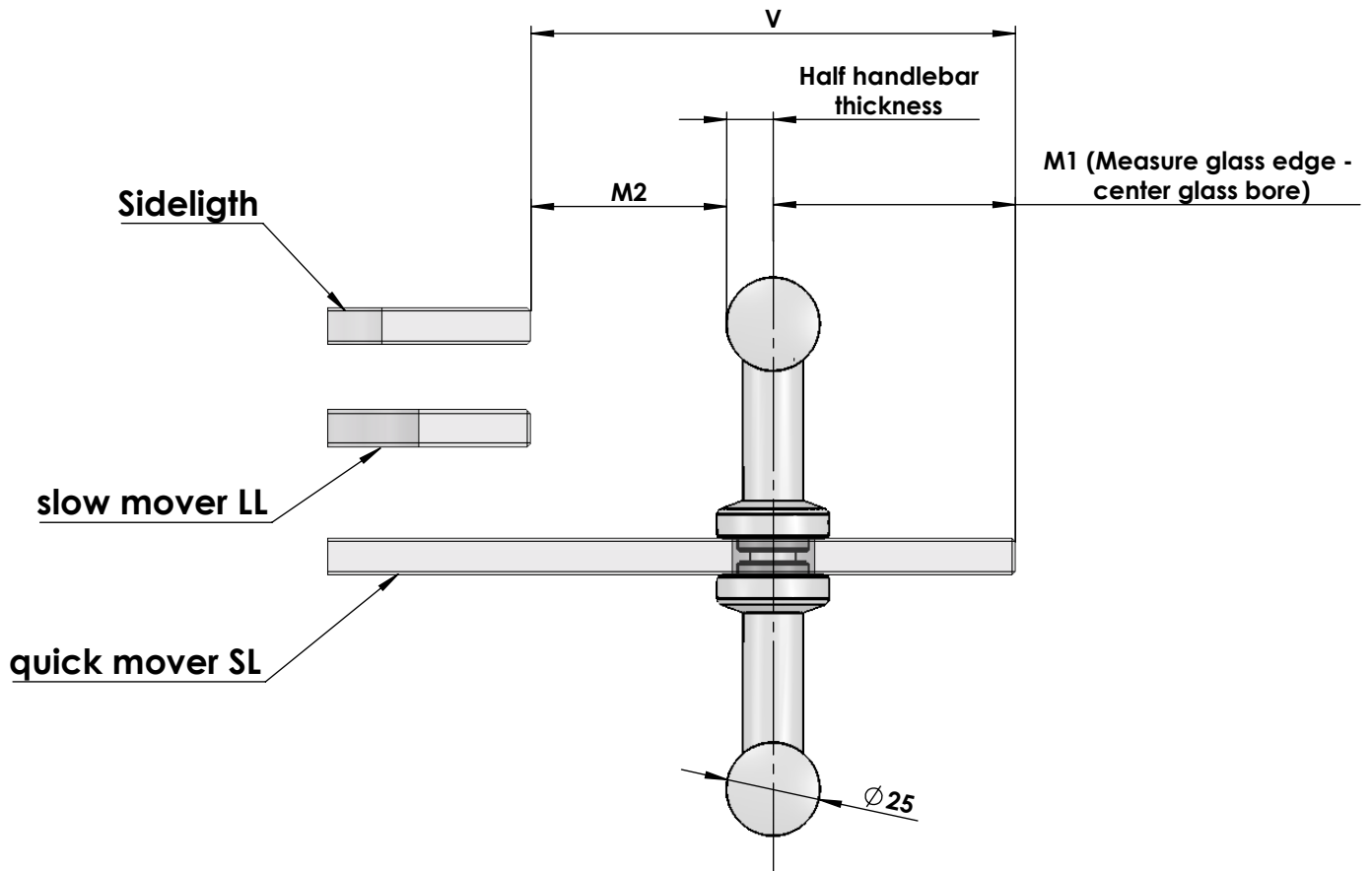

M1	Measure glass edge - center glass bore
M2	Dimension for clamping freedom (recommended 37mm)

Example for measure V:

$$\begin{aligned}
 V &= M1 + \text{halfhandlebar thickness} + M2 \\
 V &= 80\text{mm} + 13\text{mm} + 37\text{mm} \\
 V &= 130\text{mm}
 \end{aligned}$$