

# Axessor Apexx Series Keypads

## Keypad Installation Guide

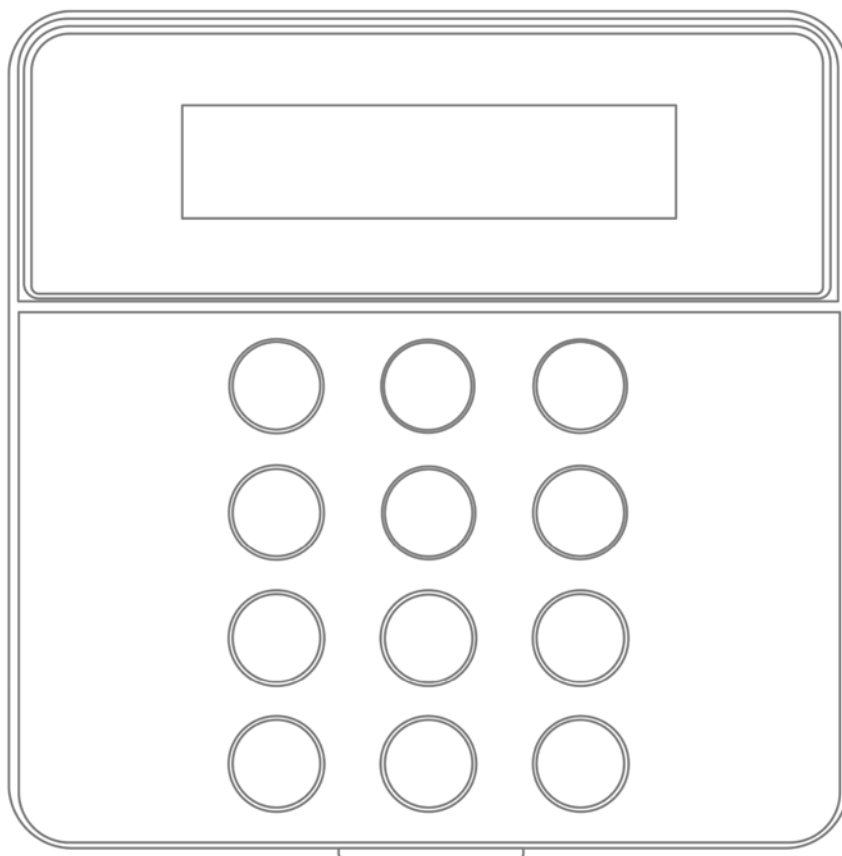

# Table of Contents

Required Tools/Parts .....	2
Tools: 2 .....	
Parts/Accessories: .....	2
Optional Parts/Accessories: .....	2
System Components and Connections .....	3
System Components .....	3
System Configurations .....	3
System Power Options .....	3
CAN bus Wiring, Cable Lengths, and Termination .....	3
Mount an Axessor Apexx Keypad .....	4
Mounting an Apexx Series Lock .....	6
Mounting an Apexx Series Lock (Deadbolt or Slambolt) .....	7
External Connections to the Apexx Series Lock .....	8
Protection from Magnetic Attack .....	9
Apexx Series Lock - Case Hole & Layout Diagram .....	9
Maximum Bolt Load .....	9
Deadbolt or Slambolt: .....	9
Apexx Series Lock Dimensions – Deadbolt/Slambolt .....	10
Mounting an Apexx eBox (optional) .....	11
Option A: tape mount: .....	11
Option B – screw mount: .....	11
Apexx eBox Case Hole & Layout Diagram .....	11
Apexx eBox Terminal Block Connections .....	12
Connect a Safe Lock to a Keypad .....	13
Axessor Apexx Keypad - Battery Access & Installation .....	14
Battery Installation – Axessor Apexx Keypad .....	14
Alternative Power Methods .....	15
Apexx Series Lock & eBox Connector Diagrams .....	15
eBox AC Line Power Adapter – Apexx eBox .....	16
Power Over Ethernet (PoE) – Apexx eBox .....	16
Emergency Power – USB* .....	17
Factory Mode .....	18
Initial Setup – Commissioning your first lock and creating an Administrator User .....	19
Specifications .....	20
Batteries .....	20
Environmental .....	20
Approved Standards .....	20
Safe Lock Models .....	21
System Wiring Diagram – Example Setup #1 .....	22
System Wiring Diagram – Example Setup #2 .....	23
System Wiring Diagram – Example Setup #3 .....	24
Drill and Tap Template – Axessor Apexx Keypad .....	25
Drill and Tap Template Apexx eBox .....	26
Drill and Tap Template – Apexx Series Lock .....	27



# Required Tools/Parts

## Tools:

- Phillips Head Screwdriver
- .050" Hex Key (included with all keypad orders)
- Drill (for new installation)
- Drill Bits (for new installation)
  - #29drill (.136", 3.3mm)
  - #7drill, 13/64 (.203", 5mm)
  - #27 drill bit (8/32", 3.5mm)
  - #28 drill bit
- Tap Set (for new installation)
  - US Customary 8-32 and 1/4-20
  - Metric M4-0.7 and M6-1.0

## Parts/Accessories:

- Axessor Apexx Keypad (faceplate + baseplate) – part#s 81100BKBKZZZZZZ0 and 81100BKSCZZZZZZ0
- Apexx Series Lock(s) – part#s ZZZZZZZZZL120010\*, ZZZZZZZZZL120000, ZZZZZZZZZL2ZZZ10\*, and ZZZZZZZZZL2ZZZ00 (\* = includes Re-locker provisions)
- Apexx Series Lock Cables – part#s 802022, 802023, 802024, 802025 and 802026
  - **Note:** These cables are backwards compatible with Axessor cables.
- Apexx Drill Protection Plate – part#804008 (if installing over existing spindle hole)
- Apexx Termination Connector – part# 802021 (pack of 25)
- Apexx Re-locker Plate – part#804017 (Requires lock with Re-locker Provisions)
- 4 "AA" (LR6) Batteries – Duracell or Energizer recommended

Mounting Hardware				
	Hardware Type	Size/spec.	Used For	Quantity
	Screw	Metric M4-07 or US Customary Unit #8-32	Keypad Installation	2 per Keypad (included)
	Screw	Metric M6 or US Customary Unit #1/4-20	Lock Installation	3 per Lock (included)
	Nut	US Customary Unit #6-32	Apexx Re-locker Plate Installation	2 per Apexx Re-locker Plate (not included)

## Optional Parts/Accessories:

- Apexx eBox – part# 807001
- Power Adapter for Apexx eBox – part# 802027

# System Components and Connections

## System Components

- A Safe lock system can consist of the following components:
  - An Apexx Series Keypad (required)
  - An Apexx Series Lock (required)
  - An Apexx eBox (optional)
  - AC power adapter – for Apexx eBox (optional)
  - A secondary Apexx Series Keypad (optional)
  - Additional Apexx Series Locks (optional)

## System Configurations

- All connections between system components are done via specialized 6-connector CAN bus cables (Apexx Series Lock Cables). **Note:** These cables are backwards compatible with Axessor cables.
- Minimum System can consist of 1 Keypad, 1 Lock
- Systems can support up to 2 Keypads, 16 Locks, and 1 eBox on the same CAN bus
- See System Wiring Diagram – Example Setup #1, System Wiring Diagram – Example Setup #2, and System Wiring Diagram – Example Setup #3 for reference

## System Power Options

- Systems with up to 2 Apexx Series Locks:
  - Battery power via the Keypad
- Systems with greater than 2 Apexx Series Locks (see “Alternative Power Methods” section):
  - Battery power via the Keypad (not recommended)
  - AC power adapter supplied to the eBox
  - External DC power connected to the eBox
  - Power Over Ethernet (PoE) by connecting PoE power sourcing equipment to the eBox. **UL compliance was verified with a PoE (PSE injector) Manufactured by Phihong, Model POE16R-560LR (Rated input 100-240VAC (0.8A) 50/60 Hz Output 56VDC, 0.275A (PSE injector))**

## CAN bus Wiring, Cable Lengths, and Termination

- The combined cable length of the CAN bus (measured between the power source and the end of the CAN bus) should be no longer than 15m with no more than 8 locks in one set of connections. Refer to the System Wiring Diagrams at the end of the document for example system setups.
- The CAN bus must be terminated at the end of the CAN bus line, meaning that the final lock of the system must not have any of its two connector ports open. The CAN bus can be terminated in one of the following ways:
  - Connecting a secondary Keypad at the end of the CAN bus
  - Connecting a Apexx Termination Connector at the end of the CAN bus

# Mount an Axessor Apexx Keypad

## NOTICE

Do not close the safe door until all installation steps have been completed:

Prior to connecting a safe lock to a Keypad, the Keypad must first be mounted to the exterior of the safe door. Follow these steps to properly mount a Keypad to the safe door:

1. Drill and tap the holes into the outside of the safe wall using the provided drill and tap template. Deburr the center hole with a file or rotary tool.

**NOTICE:** Some safe manufacturers might include these holes at the OEM level.

- Mounting holes (1)&(2) or (3)&(4) > for steel surfaces, use standard screw kit #27, metric 3.5
- Center hole (5) > for steel surfaces, Min: 0.4" (10mm), Max: 0.5" (12.5mm)

**NOTICE:** If you are drilling into another surface type (non-steel), you may need to adjust your drill sizes accordingly

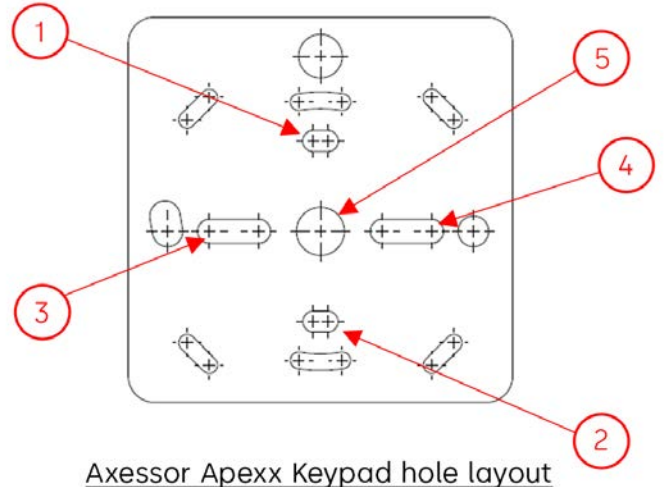

Axessor Apexx Keypad hole layout

2. Separate the keypad's faceplate and baseplate by doing the following:

- Press the spring-loaded button on the bottom of the keypad. If you have difficulty pressing the button, ensure that the button's set screw has been loosened, then try again.
- While still pressing the button, lift the faceplate away from the baseplate. The faceplate is connected to the baseplate by two hinges at the top of the keypad.

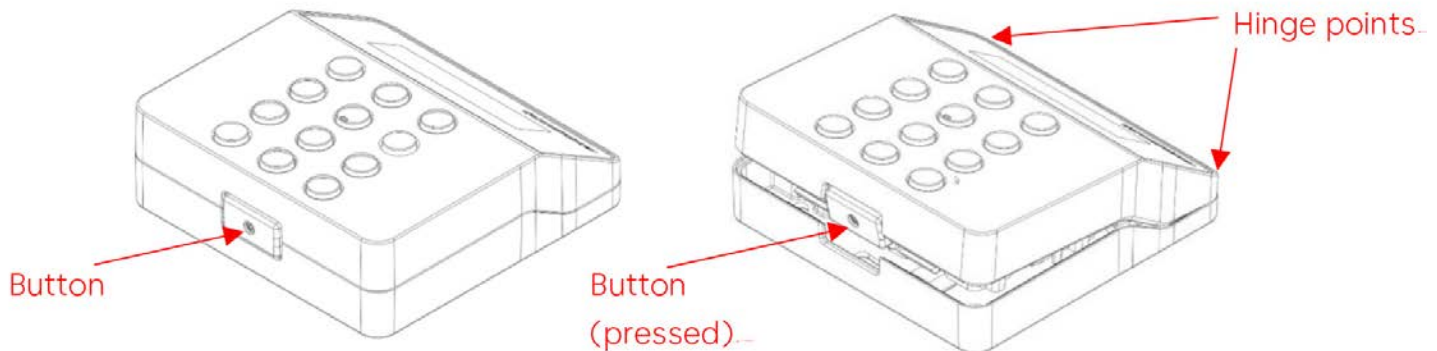

- Gently lift the bottom of the faceplate up, allowing it to swing upwards along the hinge, then lift away from the baseplate to separate.

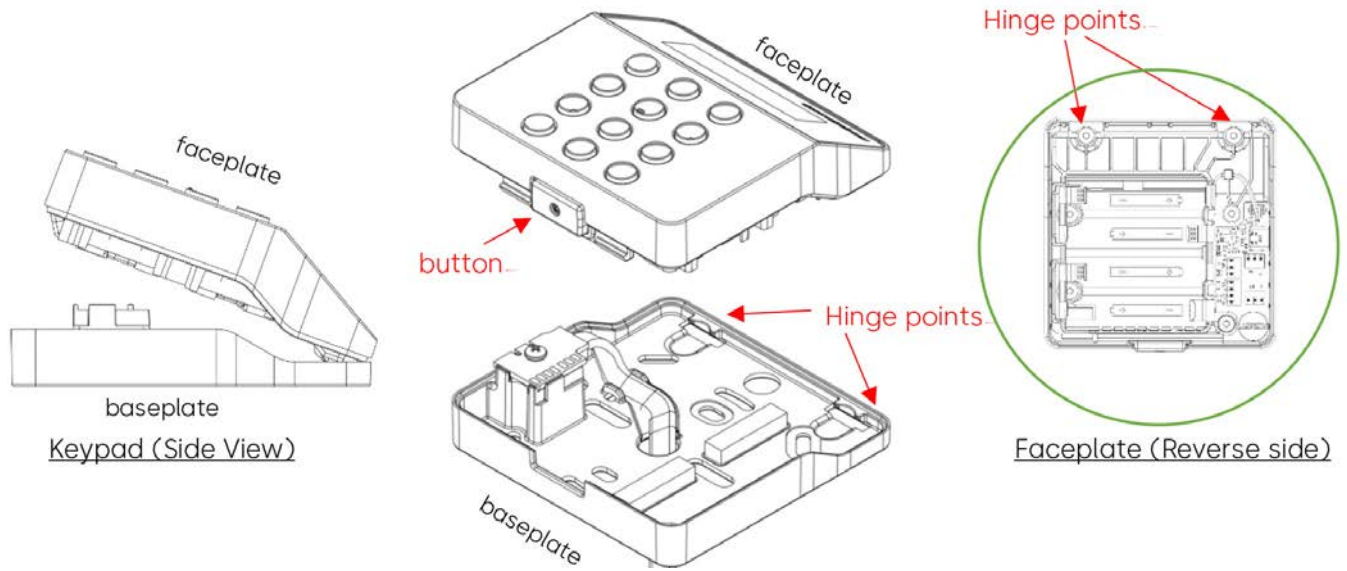

3. Run the keypad connector cable through the center hole in the safe door.

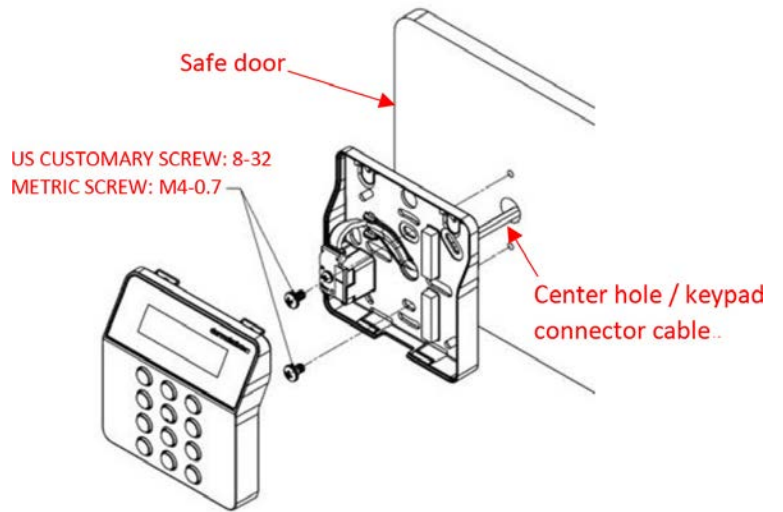

4. Attach the Keypad baseplate onto the safe door using the provided Phillips head screws. The screws provided come in two variants: Metric M4-07 or US Customary Unit #8-32. Mounting method 1) use screw holes 1 and 2. Mounting method 2) use screw holes 3 and 4. The Keypad connector cable is fed through hole 5.

**NOTICE**

If installing over a spindle hole, UL approval requires the installation of a drill protection plate.

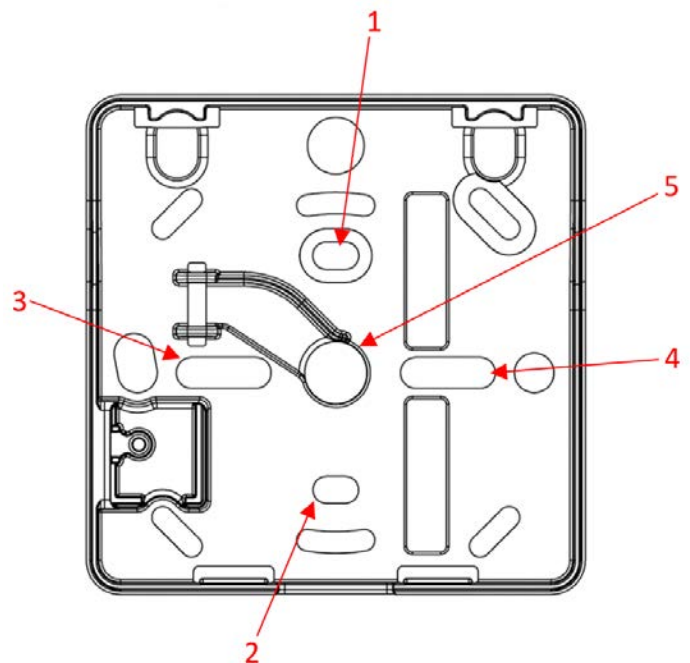

# Mounting an Apex Series Lock

Prior to connecting a safe lock to a Keypad, each safe lock must first be mounted to the interior of the safe door.

## NOTICE

### Observe the following when installing a safe lock:

- Only mount the lock using the provided mounting screws
- Recommended mounting screw torque: 30 in-lbf (3.4 Nm)
- The mounting screws have a nylon patch that acts to lock the screw in place. Additional thread lock is not recommended.
- There shall be no openings in the door of the strongbox or strongroom in the area where the lock is installed.
- Do not close the safe door until all the installation steps have been completed.
- Do not damage or remove the warranty seal or the VdS Label. Damage or removal of these labels will void the product warranty and VdS approval respectively.
- If using the lock's slambolt function, remove the retainer screw underneath the VdS label. Operating the lock in slambolt mode voids the VdS approval.

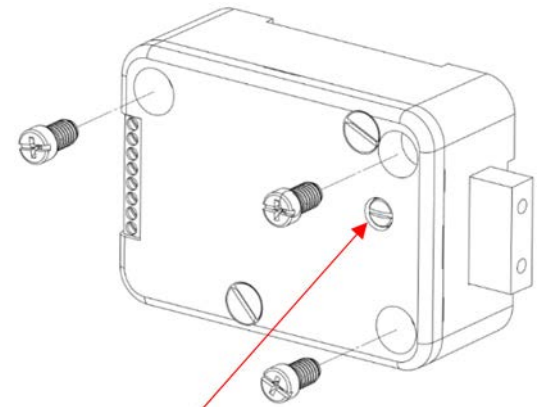

Retainer Screw for slambolt function (beneath VdS symbol on label)

US CUSTOMARY NUT: #6-32

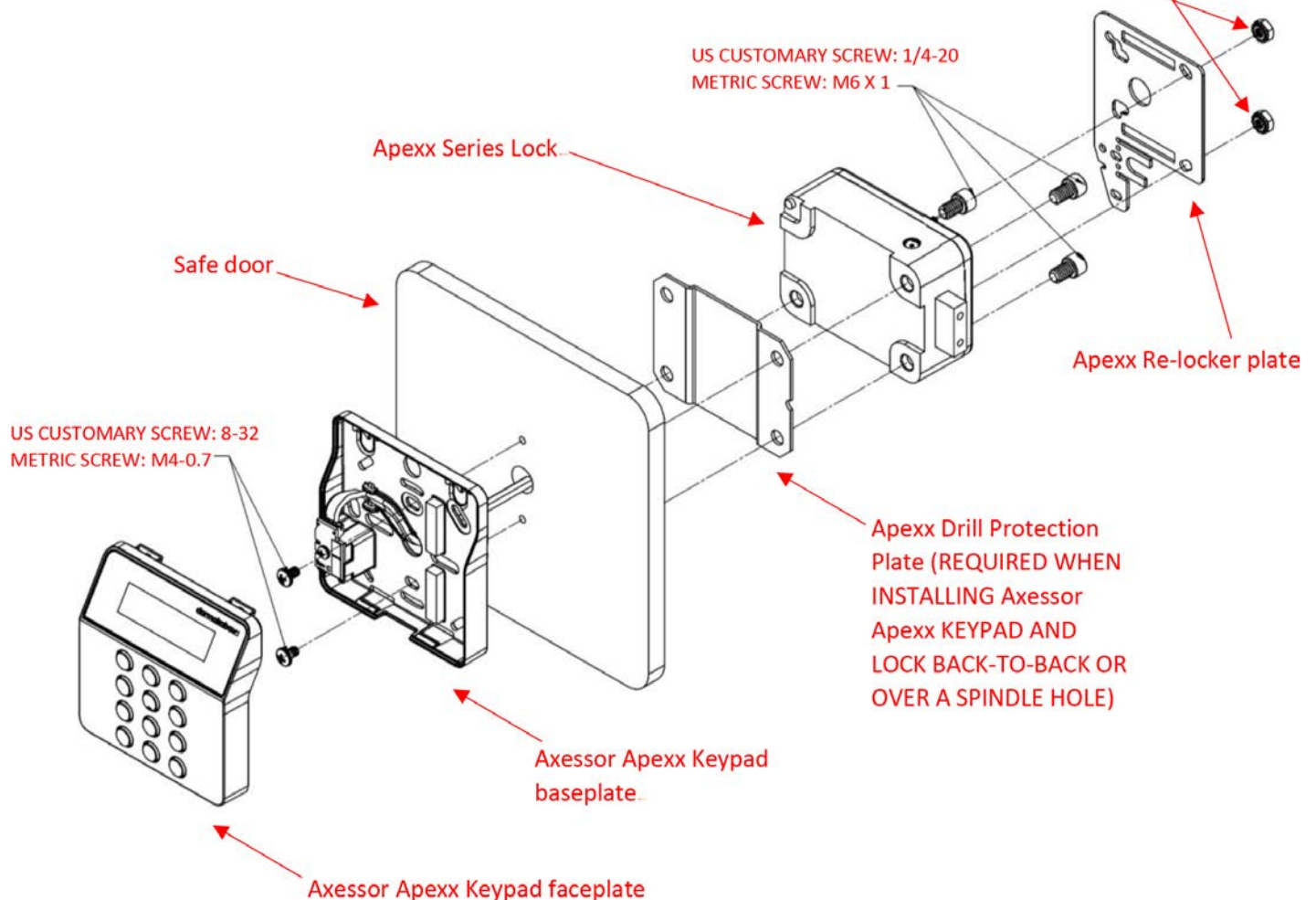

# Mounting an Apex Series Lock (Deadbolt or Slambolt)

If mounting an Apex Series deadbolt or slambolt lock, do the following:

1. On the inside of the safe door, use the provided drilling template to mark the locations of the mounting holes.
2. Drill the mounting holes using the provided template and tap for either 1/4-20 or M6-1.0.
3. Deburr all mounting holes, then install a 1/4-20 or M6 thread into each of the three mounting holes.
4. Install the Keypad on the front of the safe door using the Keypad Installation instructions described earlier.
5. If you are installing the Axessor Apex Keypad and Lock back-to-back over a spindle hole, align the drill protection plate over the mounting holes, then mount the lock on top of the drill protection plate.
6. Secure the drill protection plate and lock to the safe door using the three supplied 1/4-20 or M6 screws.

**The drill protection plate adds protection and is used to prevent unwanted lock access when a lock and keypad are installed back-to-back over a spindle/cable hole. The use of a drill protection plate is a UL requirement.**

7. If installing a Re-locker plate, align the plate with the two re-locker mounting studs on the back of the lock, then fasten in place with the two 6-32 nuts.
8. If using the lock's slambolt function, remove the retainer screw underneath the VdS label.

**NOTICE:** Operating the lock in slambolt mode voids the VdS approval.

9. If required, you can install two M4 threads into the end of the bolt to add an extension to increase the length of the bolt.

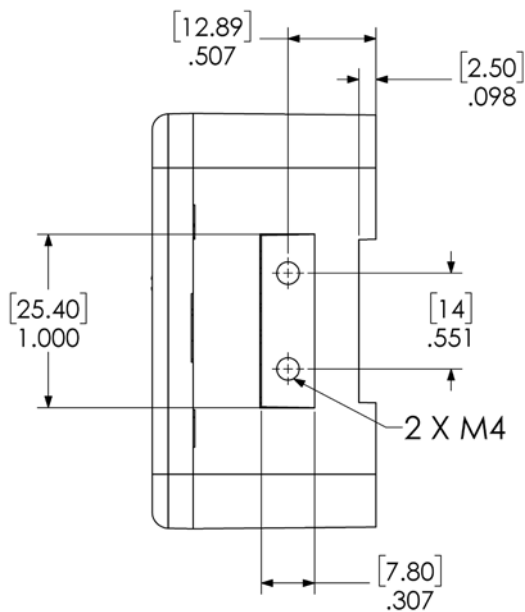
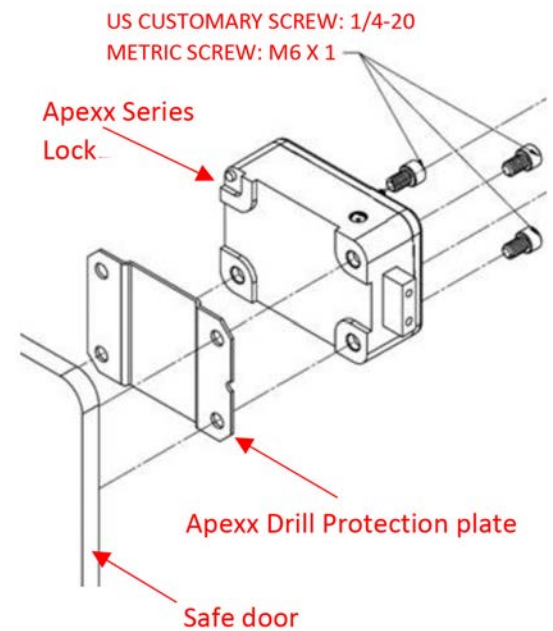

Apex Series Lock (profile view)

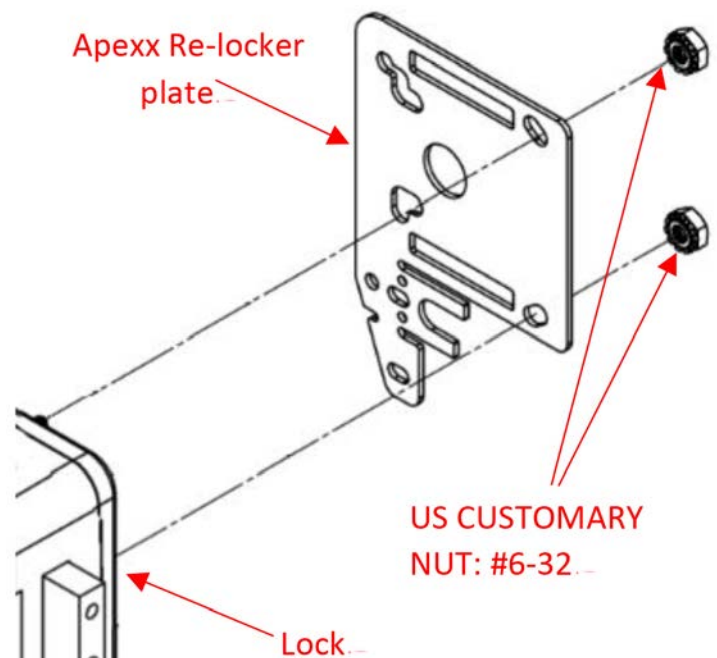



# External Connections to the Apexx Series Lock

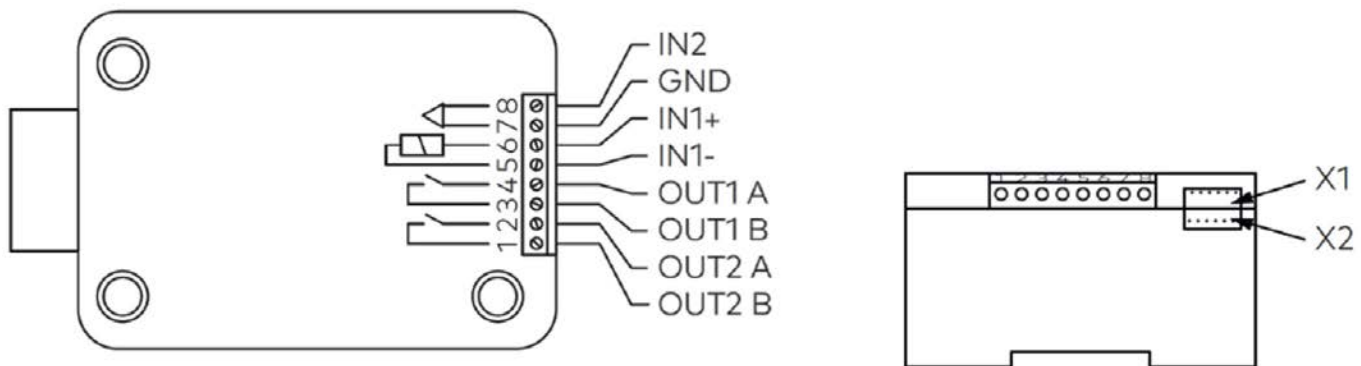

Terminal/ Socket #	Description	Unit	Notes
1 / 2	<b>Output 2</b> Factory setting: lock open (OR Boolean operation with bolt open, motor open, or door open)	Resistive Load: 30VDC / 2A 30VAC / 0.5A	Relay with potential-free working contact, Normally Open (NO). Contact is open when lock is closed.
3 / 4	<b>Output 1</b> Factory setting: duress alarm	Resistive Load: 30VDC / 2A 30VAC / 0.5A	Relay with potential-free working contact, Normally Open (NO). Contact is closed when duress alarm is active. Duress function not evaluated by UL
5(-) / 6(+)	<b>Input 1</b> Factory setting: off (not assigned)	12VDC / min. 13mA, max. 20mA	—
7 / 8	<b>Input 2</b> Factory setting: off (not assigned)	Potential-free contact only ( <b>do not apply any voltage!</b> )	Use a micro switch with gold-plated contact 12VDC/50mA (e.g., DB series by Cherry). If Input 2 is assigned as "door contact" and not inverted, an <b>open switch contact</b> stands for " <b>door open</b> ".  The bolt is open as long as pins 7 and 8 remain electrically disconnected.
X1 / X2	Connection for input unit (Keypad), eBox, power supply, or termination connector	—	Use only the connecting cables provided

All safe lock inputs and outputs can be configured using the Apexx Series Software.

## NOTICE

**Important!** If running Duress through the eBox, the duress signal would not be sent in the event of a power loss. For this reason, dormakaba recommends that the Duress signal be run directly from a lock to the alarm system.

# Protection from Magnetic Attack

In order for a safe to be protected from magnetic attack the container must be made from (or contain) a steel protective layer capable of diverting magnetic fields.

## Apexx Series Lock - Case Hole & Layout Diagram

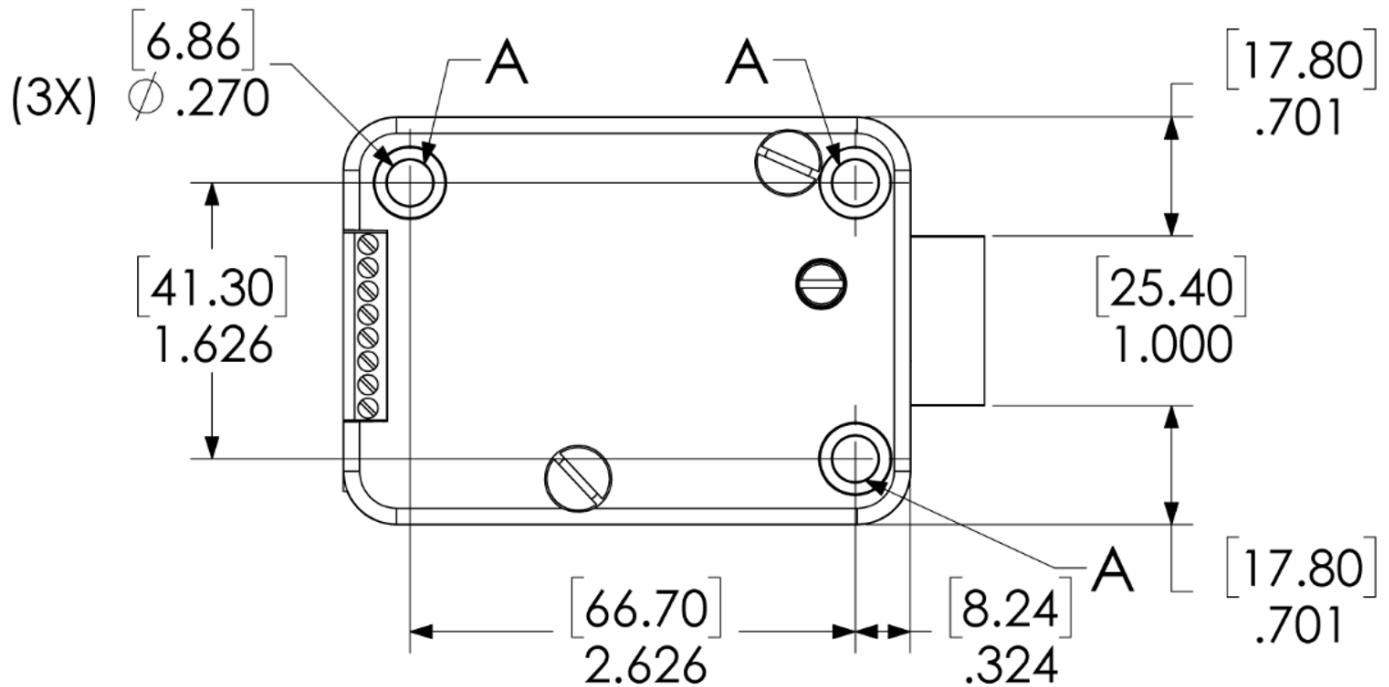

## Maximum Bolt Load

### Deadbolt or Slambolt:

- Maximum load movable by the bolt: 1.12 lbs. (5N)\*

**NOTICE:** Apexx Series motorized deadbolt locks may not open if more than 1.12 lbs. (5N)\* of force is applied to the end or side of the bolt.

- Maximum load against bolt when thrown (all directions): 224.8 lbs. (1kN)\*

\* Force not evaluated by UL

# Apexx Series Lock Dimensions – Deadbolt/Slambolt

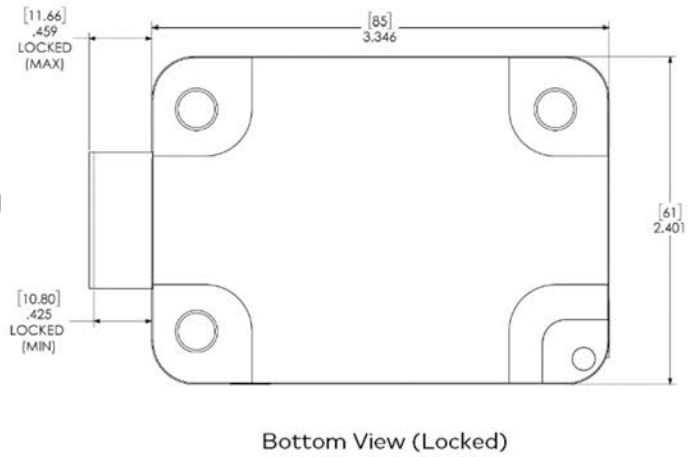
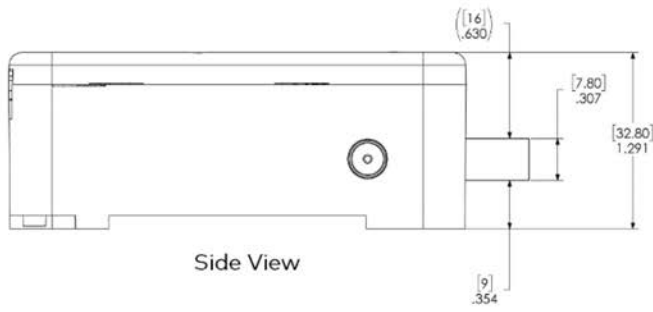
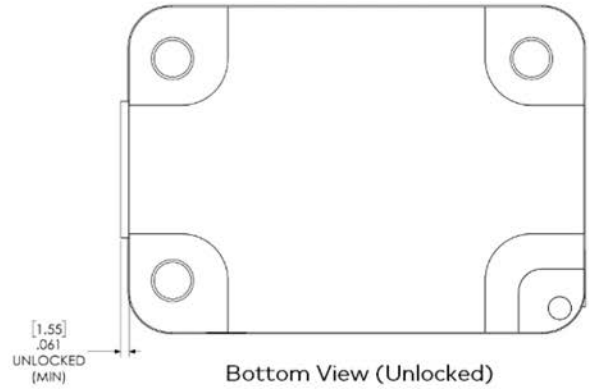
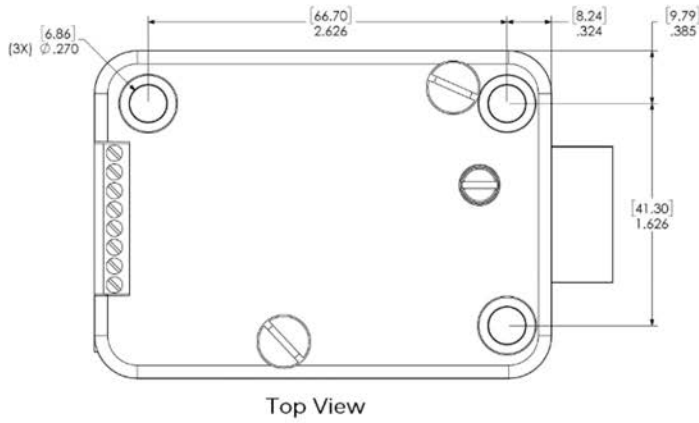

# Mounting an Apexx eBox (optional)

## NOTICE

As a requirement of EN 1300, the eBox must be installed inside the safe.

If using the optional Apexx eBox as part of your safe lock setup, follow the steps below to mount the device:

### Option A: tape mount:

As an alternate mounting method, the eBox also comes with double-sided tape that can be used to adhere the underside of the eBox to the inside of the safe.

1. Remove the protective layer from one side of the double-sided tape then stick it to the bottom of the Apexx eBox.
2. Remove the protective layer from the other side of the tape, then mount the Apexx eBox onto the mounting surface, pressing firmly to ensure adherence.

**NOTICE:** for best results, ensure the surface you are mounting to has been cleaned.

### Option B – screw mount:

1. Mark the two mounting holes as shown on the Apexx eBox Case Hole & Layout Diagram.
2. Drill and tap the mounting holes using the provided template. For M4-0.7 x 6mm long mounting screws drill  $\varnothing 3.5\text{mm}$  and tap, or  $\varnothing .144$  if using the #8-32 x .25in long mounting screws.
3. Deburr all mounting holes.
4. Place the eBox over the mounting holes, then mount it using the appropriate set of supplied mounting screws.

## Apexx eBox Case Hole & Layout Diagram

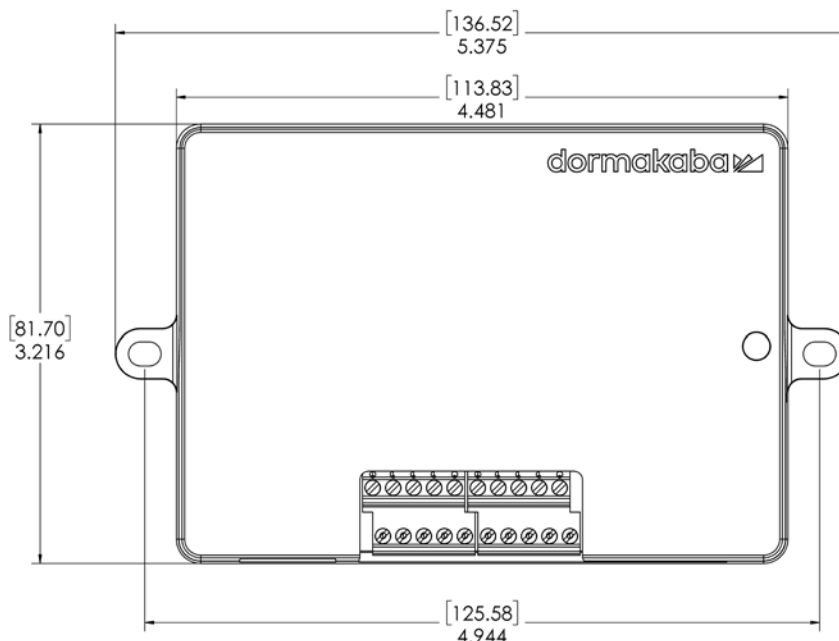

# Apexx eBox Terminal Block Connections

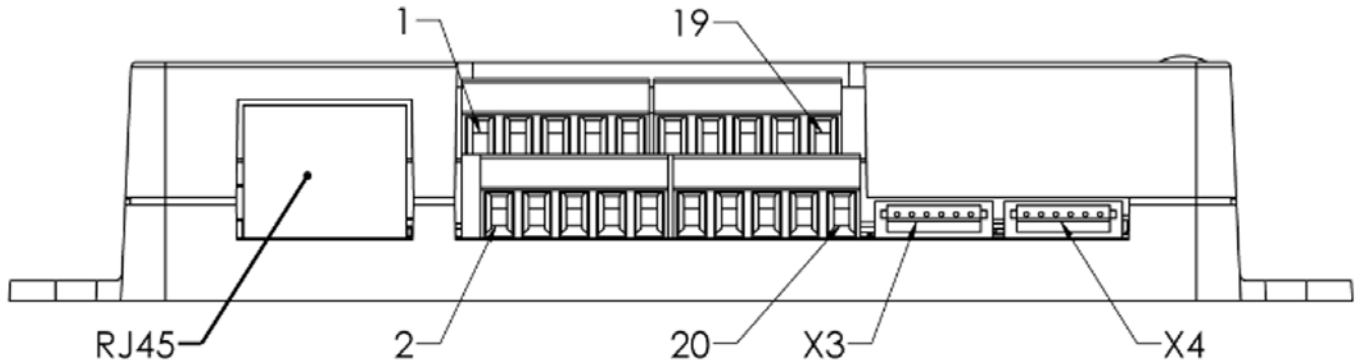

Pin Number Pairs	Description	Unit	Notes
<b>1 / 2</b> – ISO Input 1 / ISO Input 1 GND <b>3 / 4</b> – ISO Input 2 / ISO Input 2 GND <b>5 / 6</b> – ISO Input 3 / ISO Input 3 GND	Factory setting: OFF (not assigned)  Inputs 1, 2, and 3 are configurable through software	Potential-free contact only ( <b>do not apply any voltage!</b> )	Use a micro switch with gold-plated contact 12VDC/50mA (e.g., DB series by Cherry). The Signal is open as long as pins remain electrically disconnected.
<b>7 / 8</b> – Relay Output 1 (+) / Relay Output 1 (-) <b>9 / 10</b> – Relay Output 2 (+) / Relay Output 2 (-) <b>11 / 12</b> – Relay Output 3 (+) / Relay Output 3 (-)	Factory setting: OFF (not assigned)  Outputs 1, 2, and 3 are configurable through software	Resistive Load: 30VDC / 2A 30VAC / 0.5A	eBox contains a relay with potential-free working contact for output. Output pins will be shorted together when signal is asserted and open when unasserted.
<b>13/14</b> – Tamper Input 1 / Tamper Input 1 GND <b>15/16</b> – Tamper Input 2 / Tamper Input 2 GND <b>17/18</b> – Tamper Input 3 / Tamper Input	Factory setting: OFF (not assigned)  Tamper Inputs 1, 2, and 3 are configurable through software	Potential-free contact only ( <b>do not apply any voltage!</b> )	Refer to “eBox Tamper Switch Resistor Configuration” section for proper wiring details
<b>19 / 20</b> – Power Supply (+) / Power Supply GND (-)	Power Connection	dormakaba recommends using part # 802027 for this power option	Refer to “Alternative Power Methods” section for wiring details.  Operating range: 12-24V  Recommended minimum power: 5W

# Connect a Safe Lock to a Keypad

Once the Apexx Series Keypad and Lock are physically installed on the safe container, follow these steps to connect a safe lock to a Keypad:

1. For **single lock systems**, do the following:

- a. Connect the cable from the keypad into one of the two ports on the safe lock.

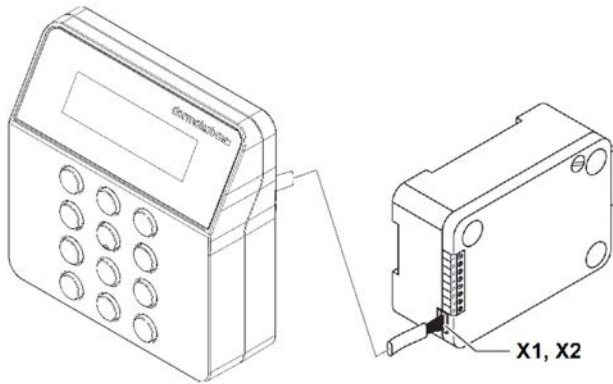

- b. Install the batteries in the keypad as outlined in the [Axessor Apexx Keypad - Battery Access & Installation](#) section of this document.
- c. Use the keypad and on-screen menu on the Axessor Apexx Keypad to logically install and commission the locks (and eBox, if using one). Refer to Initial Setup – Commissioning your first lock and creating an Administrator User for more details, or consult the Apexx System User Guide (Document #802.0622).

2. For **multi-lock systems**, do the following:

- a. Connect the cable from the Keypad to one of the two ports on the first safe lock (known as Lock #1 to the System).
- b. From the first lock, connect another cable from the unused port to one of the two ports on the second lock in your system.

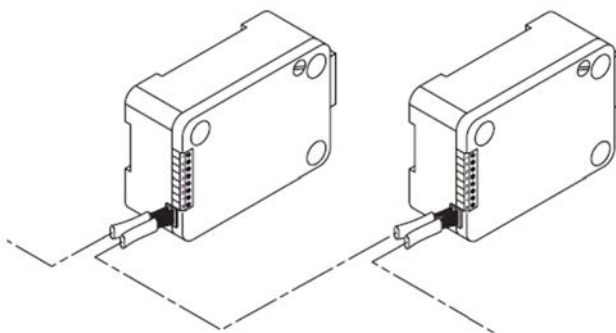

- c. Use a cable tie to secure and clean up any excess cabling.
- d. Repeat Step b and c for each additional safe lock, to create a daisy-chain connecting all the locks together. If using an eBox, you can also connect it in-line with your locks using its 6-conductor ports.
- e. Terminate the CAN bus by connecting either a second keypad or an Apexx Termination Connector to the open 6-conductor port of the final lock in your system. If the eBox is the last part of

your bus chain, terminate by connecting the secondary keypad or Apexx Termination Connector to the open 6-connector port on the eBox.

- f. Apply power to the system using one of the following methods:
- Battery power via the Keypad
  - AC power adapter supplied to the locks
  - External DC power connected to the eBox
  - Power Over Ethernet (PoE) by connecting PoE power sourcing equipment to the eBox

Refer to the [Axessor Apexx Keypad - Battery Access & Installation and Alternative Power Methods](#) sections of this document for more details.

- g. Use the keypad and on-screen menu on the Axessor Apexx Keypad to logically install and commission the locks (and eBox, if using one). Refer to Initial Setup – Commissioning your first lock and creating an Administrator User for more details, or consult the Apexx System User Guide (Document #802.0622).

## Axessor Apexx Keypad - Battery Access & Installation

The Axessor Apexx keypad is powered internally using 4 x AA (LR6) batteries (Duracell, Energizer) . These batteries are sufficient to run a system with a single keypad and one or two locks. For systems using more than 2 locks, an AC power adapter or an eBox are required to provide system power.

### NOTICE

When removing and replacing the keypad faceplate, be sure to hold the unit tightly to avoid dropping it and causing damage.

If using batteries in the entry as a secondary/backup power source, please note the following:

- Batteries should be replaced on a regular basis. The frequency of backup battery replacement will depend on the quality of the batteries used.
- After a power outage, it is recommended that the backup batteries are replaced with new ones once the power has been restored.

## Battery Installation – Axessor Apexx Keypad

For Axessor Apexx Keypads, do the following to access and install the batteries:

1. If you haven't done so already, separate the keypad's faceplate and baseplate. To do this, press the spring-loaded button on the bottom of the keypad. While still pressing the button, pull the faceplate away from the baseplate. The faceplate is connected to the baseplate by two hinges at the top of the keypad. Gently lift the bottom of the faceplate up, allowing it to swing upwards along the hinge, then lift away from the baseplate to separate.

- The Axessor Apexx Keypad's battery holder is built-in to the keypad's faceplate. Install the four batteries, one at a time, into the battery holder. Use the markers in the battery holder to ensure proper +/- orientation for each battery.

**NOTICE**

**Important!** DO NOT remove any of the internal screws inside of the keypad. This could damage the device and void the warranty.

- When finished installing the batteries, reattach the faceplate by inserting the two hinges back into their respective slots along the top of the baseplate, then hinging downward and pressing firmly until the faceplate locks in place. You should hear a loud "snap" sound, indicating that the spring-loaded button has secured the faceplate in place.
- Use the provided .050" drive to tighten the set screw into the threaded hole on the spring-loaded button at the bottom of the keypad. Rotate the screw clockwise until the button is secured in place and not able to be operated by hand. This screw will hold the faceplate and backplate of the keypad together so that they aren't accidentally dislodged.
- If using two keypads in your system setup, repeat steps 1-4 to install batteries in your second keypad.

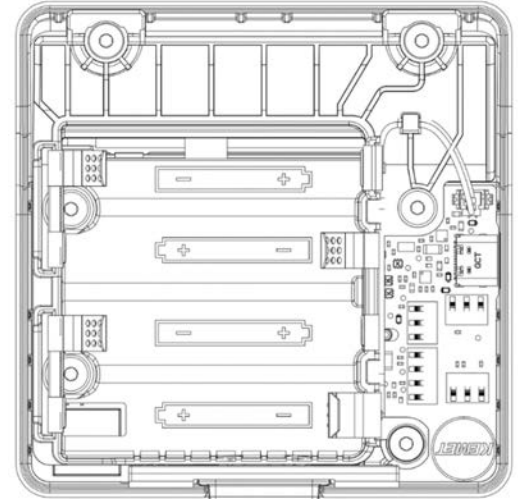

Faceplate (Interior)

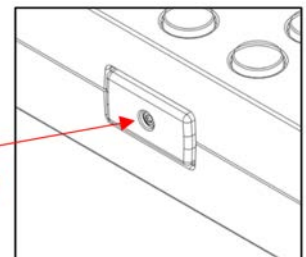

Hole for set screw

## Alternative Power Methods

Though battery power alone is often enough suitable to run most lock smaller lock systems, it is recommended that larger multi-lock systems utilize one of the alternative power methods described in this section.

### Apexx Series Lock & eBox Connector Diagrams

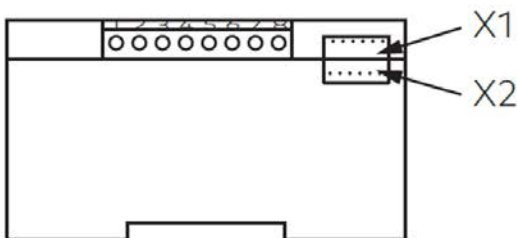

Apexx Series Lock

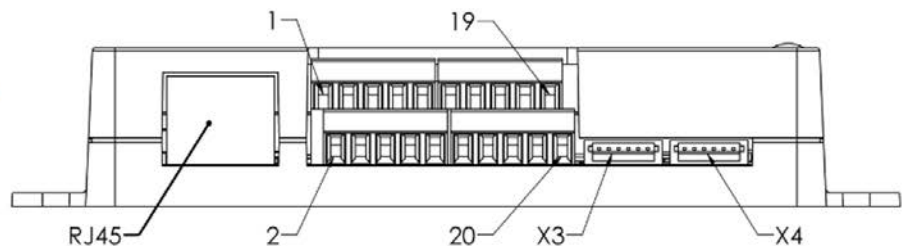

Apexx eBox



# eBox AC Line Power Adapter – Apexx eBox

The optional Apexx eBox can be used to provide system power using an AC power adapter. The Apexx eBox can accept a 12-24V input voltage range. dormakaba recommends you use part# 802027, which consists of a 12V, 5W power supply, and a cable adapter to connect the power supply to the terminal connectors on the eBox. **(UL tests were performed with a PSA15R-120P6-R AC/DC wall adapter, manufactured by Phihong Rated input 100-240VAC (0.8A) 50/60 Hz Output 12 Volt DC 1.25A)**

Observe the following steps when connecting the AC power adapter to the Apexx eBox:

1. Once all other system connections are complete, connect the cable adapter to the terminal blocks of the eBox.

- a. Insert the negative wire (black) of the cable adapter into terminal contact 20, then use a screwdriver to tighten the terminal contact to secure the wire in place.
- b. Insert the positive wire (with white dashed line) of the power adapter into terminal contact 19, then use a screwdriver to tighten the terminal contact to secure the wire in place.

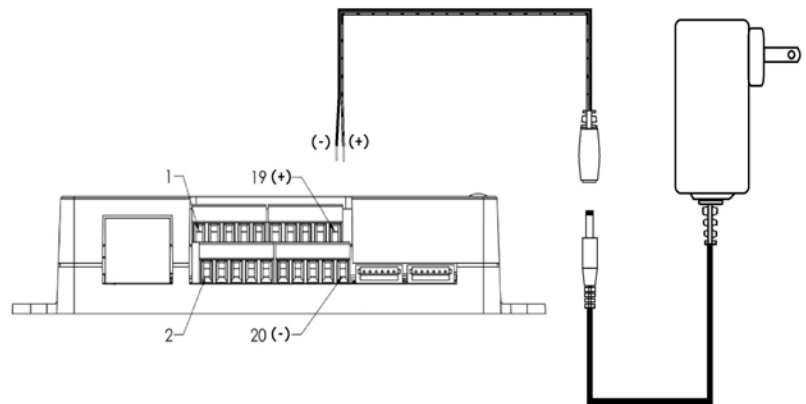

2. Ensure that the male barrel connector of the power supply is plugged firmly into female barrel connector of the cable adapter, then plug the other end of the power supply into a wall socket to provide power.
3. If the Apexx eBox is the last device on the CAN bus, insert an Apexx Termination Connector into the open port (X3 or X4).

**NOTICE:** for systems containing 6 or more locks, the eBox should be placed as close to the center /middle of CAN bus as possible to ensure even power distribution across the system.

## Power Over Ethernet (PoE) – Apexx eBox

The optional Apexx eBox can be used to provide system power by using power sourcing equipment to supply electrical power to the system via the RJ45 of the eBox. To supply system power via the eBox, do the following:

1. Once all other system connections are complete, connect an Ethernet cable from the PoE power sourcing equipment into the RJ45 Ethernet terminal on the eBox.

PSE (Power Sourcing Equipment) used with the Axessor Apexx IP needs to be capable of Class 2 from IEEE 802.3af-standard LAN-based power for each Axessor Apexx IP system connected. Before you install a Axessor Apexx IP locking system verify with the LAN administrator whether the LAN supports IEEE 802.3af Class 2, and if so, whether the Axessor Apexx IP locking system should be powered locally or by means of the LAN.

# Emergency Power – USB\*

In the event of total system power loss, the system can be powered temporarily using USB power. Simply connect the "USB" end (could be USB-A or USB-C plug type) of a "USB-to-USB-C" cable from a power-sourcing USB device (computer, USB power adapter, etc.), then connect the USB-C end of the cable into the USB-C port located on the side of the keypad.

## NOTICE

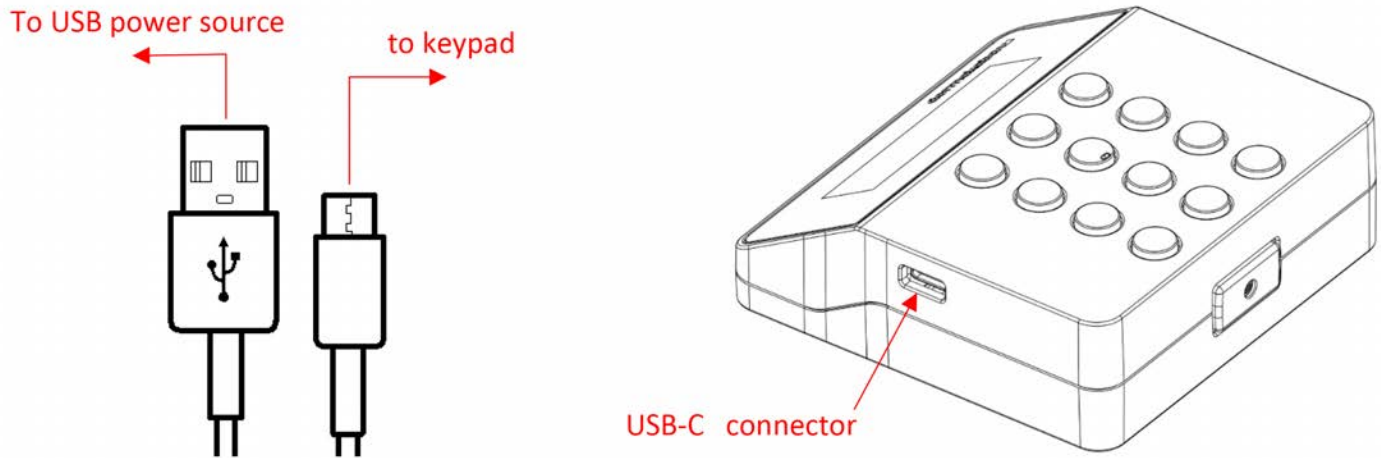

Recommended power for emergency use though USB connector is 5W (1A) for a fully loaded system.



\*USB Emergency Power function not evaluated by UL

# Factory Mode

Prior to installation, the locks are in what's known as factory mode. When the locks are in factory mode, the numeric keys on the Apexx Series Keypad can be used to perform certain functions prior to adding/installing the locks.

1. In the keypad menu, highlight the  "Add Devices" icon, then press the  Enter key.
2. "Checking System" > A system check is performed, and the number of devices found is shown on the display screen. Press the  Enter key to view all found devices. The devices will appear on the display screen in the following format: *Locks:Keypad:eBox* (will appear as numbers separated by colons)
3. A list of all new devices will appear on the display screen. Use the arrow keys to highlight name of one of the locks, then press one of the following numeric keys to perform the associated function:





Key	Function (when lock name highlighted in "Add Devices" screen)
1	<b>Bolt open</b> – The highlighted lock will open for 6-seconds, then close.
2	<b>Arrow key</b> – moves the cursor/highlight up on the keypad's display screen
3	<b>Lock I/O test</b> – toggles the outputs of the highlighted lock. If the outputs are in different states, they will all be switched to the same state after the first toggle.
4	<b>Arrow key</b> – no function
5	<b>Bolt open</b> – The highlighted lock will open for 6-seconds, then close.
6	<b>Arrow key</b> – no function
7	no function
8	<b>Arrow key</b> – moves the cursor/highlight down on the keypad's display screen
9	<b>Lock I/O test</b> – wrap test. Sets the highlighted lock's outputs based on the state of its inputs.
0	<b>Bolt open</b> – The highlighted lock will open for 6-seconds, then close.

## NOTICE

Once the installation has occurred and an initial user has been added to the system, the system is no longer in Factory Mode and the commands included in the above chart will no longer function.

# Initial Setup – Commissioning your first lock and creating an Administrator User





After the physical installation of the safe lock equipment has been completed, the devices must be logically installed (commissioned). Commissioning can be done conveniently using the keypad's menu system.

1. In the keypad menu, highlight the  *“Add Devices”* icon, then press the  Enter key.
2. *“Checking System...”* appears onscreen as a system check is performed, and the number of devices found is shown on the display screen. Press the  Enter key to view all found devices.
3. *“Add Devices”* appears onscreen along with a list of all new/found devices. Highlight the lock that you want to commission, then press the  Enter key.

**NOTICE:** You must first commission a lock before adding any other devices.



4. *“Enter Lock Number (1-16)”* > After selecting a lock, use the numeric keys to enter a valid lock number (1-16), then press the  Enter key.

**NOTICE:** It is recommended that Lock #1 be used for the outer door.

5. *“Add device?”* > Press  Enter to confirm, or  Back to cancel.
6. *“Enter New Administrator ID”* > Use the numeric keys to enter a new Administrator ID (1-10 digits), then press the  Enter key.
7. *“Set PIN Length”* > Highlight one of the PIN length options, then press the Enter key. To save the setting, highlight the word “Save”, then press the  Enter key.
8. *“Enter Administrator PIN”* > Enter a PIN for the new User, then press the  Enter key.

## NOTICE

**Important!** For improved security, ensure that the User PINs you use are not simple (e.g., 1,2,3,4,5,6) or easy to guess (based on dates, addresses, etc.).

9. *“Confirm Administrator PIN”* > Confirm the new PIN by entering it a second time, then press the  Enter key.
10. *“Select Group”* > Select a Group by highlighting the group name and press the Enter key, then scroll to the bottom of the screen and highlight the word “Save”, then press the  Enter key.
11. *“Initial Commissioning...”* appears on the display screen. After a brief period, *“Administrator Setup Success”* will appear on the display screen. Press the  Enter key to go to the Keypad Main Menu.

# Specifications

## Batteries

dormakaba used standard Duracell AA (LR6) alkaline batteries to evaluate discharge curves to determine battery cutoffs

## Environmental

Operating & Storage Temperature Range:

- For UL compliance, this product was verified for operation at 32 – 122 °F (0 – 50 °C)
- Relative Humidity Range: 0 – 95% non-condensing

## Approved Standards

The AXESSOR APEXX family of safe locks conform to the following approved standards:

- UL 2058 (High Security Electronic Locks)
- EN 1300:2018
- Model: APX01 – FCC ID: 2ASNP-APX01, IC ID: 24793-APX01



**Note:** This equipment has been tested and found to comply with the limits for a Class B digital device, pursuant to part 15 of the FCC Rules. These limits are designed to provide reasonable protection against harmful interference in a residential installation. This equipment generates, uses, and can radiate radio frequency energy and, if not installed and used in accordance with the instructions, may cause harmful interference to radio communications. However, there is no guarantee that interference will not occur in a particular installation. If this equipment does cause harmful interference to radio or television reception, which can be determined by turning the equipment off and on, the user is encouraged to try to correct the interference by one or more of the following measures:

- Reorient or relocate the receiving antenna
- Increase the separation between the equipment and receiver
- Connect the equipment into an outlet on a circuit different from that to which the receiver is connected
- Consult the dealer or an experienced radio/TV technician for help

Changes or modifications not expressly approved by dormakaba USA Inc. could void the user's authority to operate the equipment.

---

This device contains license-exempt transmitter(s)/receiver(s) that comply with Innovation, Science and Economic Development Canada's license-exempt RSS(s). Operation is subject to the following two conditions:

1. This device may not cause interference.
2. This device must accept any interference, including interference that may cause undesired operation of the device.

L'émetteur/récepteur exempt de licence contenu dans le présent appareil est conforme aux CNR d'Innovation, Sciences et Développement économique Canada applicables aux appareils radio exempts de licence.

L'exploitation est autorisée aux deux conditions suivantes :

1. L'appareil ne doit pas produire de brouillage.
2. L'appareil doit accepter tout brouillage radioélectrique subi, même si le brouillage est susceptible d'en compromettre le fonctionnement.

CET APPAREIL EST CONFORME À LA NORME RSS INDUSTRIE CANADA EXEMPT DE LICENCE. Son fonctionnement est soumis aux deux conditions suivantes:(1) Cet appareil ne doit pas provoquer d'interférences et(2) Cet appareil doit accepter toute interférence, y compris les interférences pouvant causer un mauvais fonctionnement du dispositif. Cet appareil numérique de la classe [B] respecte toutes les exigences du Règlement sur le matériel brouilleur du Canada.

## Safe Lock Models

Keypad Model "Axessor Apexx" (Input Units Keypads) for use with High Security Lock Models Apexx Motorized Deadbolt (MDB) Lock, Apexx Motorized Latchbolt (MLB) Lock.

# System Wiring Diagram – Example Setup #1

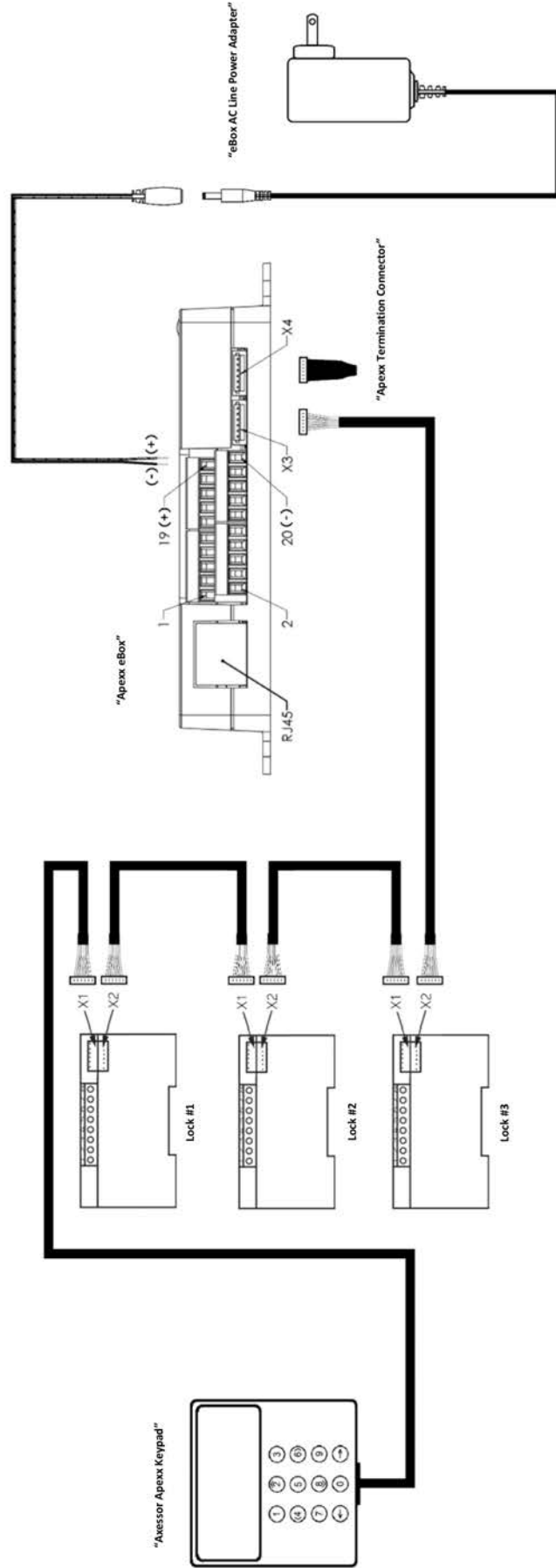

- System:
- 1 x Accessor Apex Keypad
  - 3 x Apex Series Locks
  - 1 x Apex eBox
  - 1 x eBox AC Line Power Adapter
  - 1 x Apex Termination Connector

# System Wiring Diagram – Example Setup #2

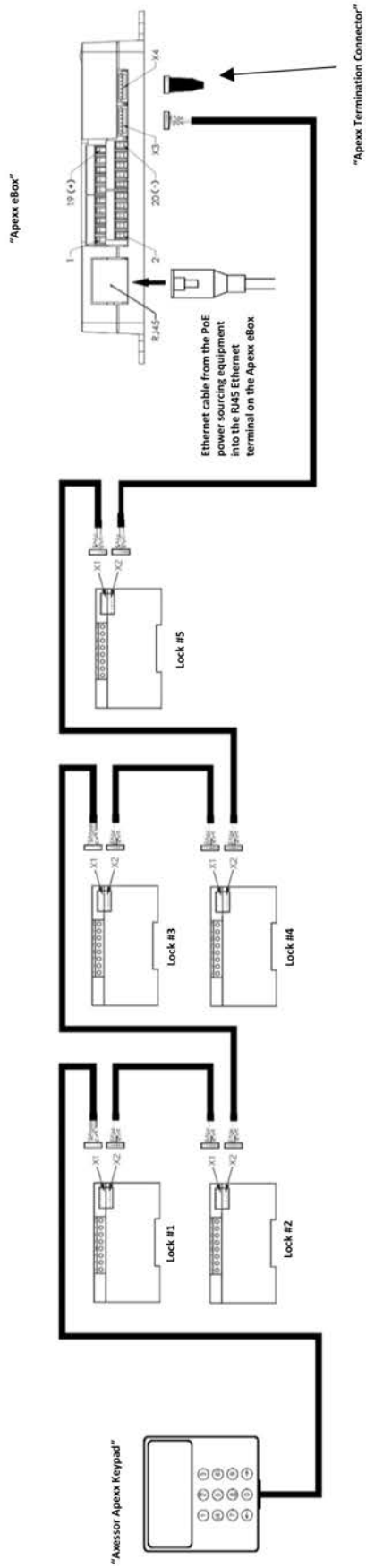

## System:

- 1 x Aressor Apex Keypad
- 5 x Apex Series Locks
- 1 x Apex eBox
- 1 x Apex Termination Connector



# System Wiring Diagram – Example Setup #3

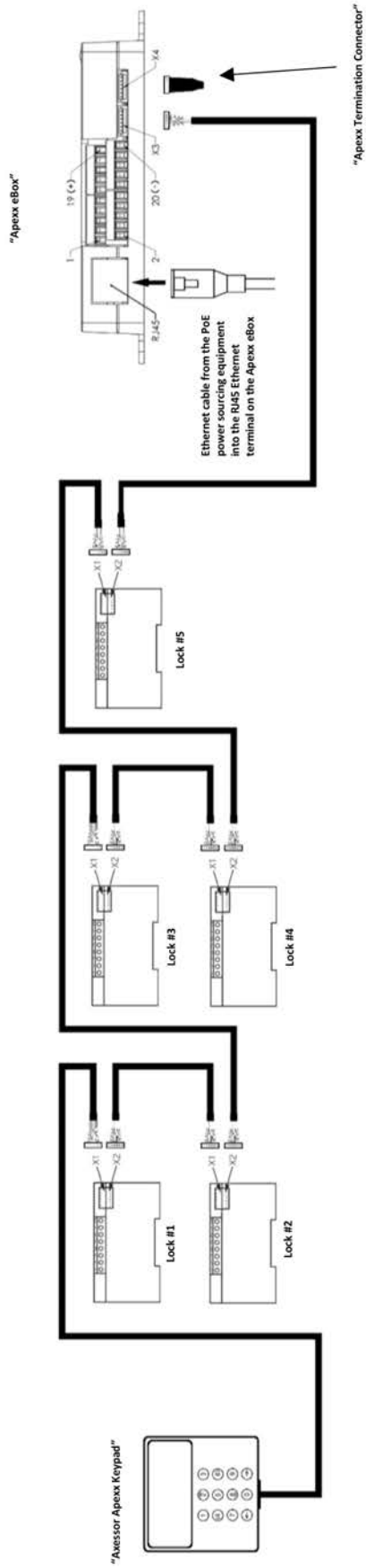

## System:

- 1 x Axxessor Apex Keypad
- 16 x Apex Series Locks
- 1 x Apex eBox
- 1 x eBox AC Line Power Adapter
- 1 x Apex Termination Connector

**NOTICE:** For systems containing 6 or more locks, the Apex eBox should be placed as close to the center /middle of CAN bus as possible to ensure even power distribution across the system.

# Drill and Tap Template – Axessor Apexx Keypad

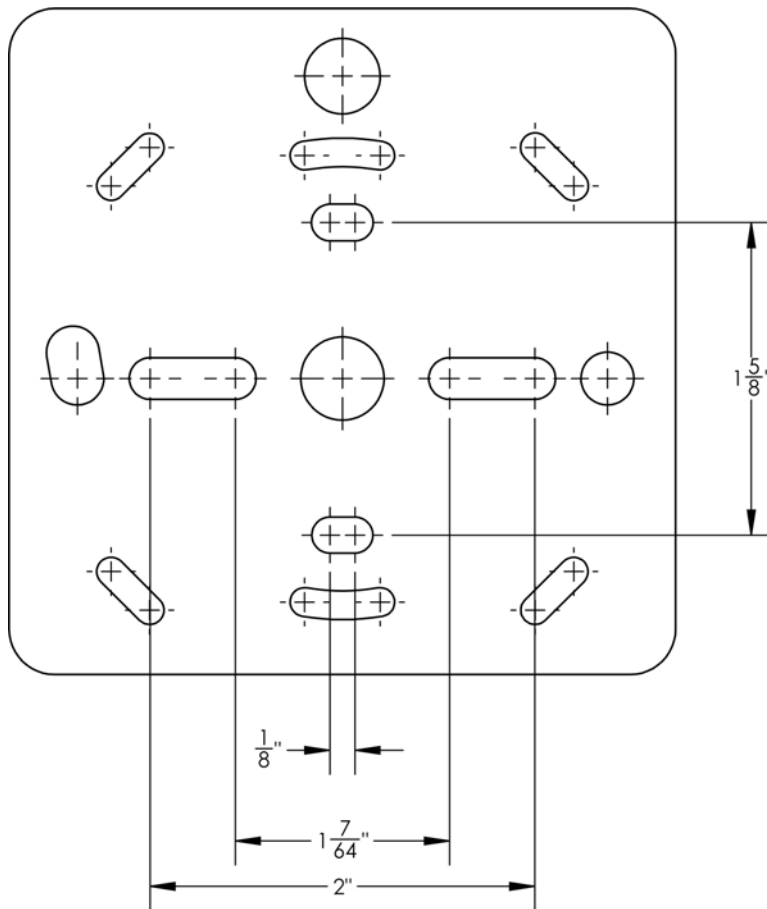

# Drill and Tap Template Apexx eBox

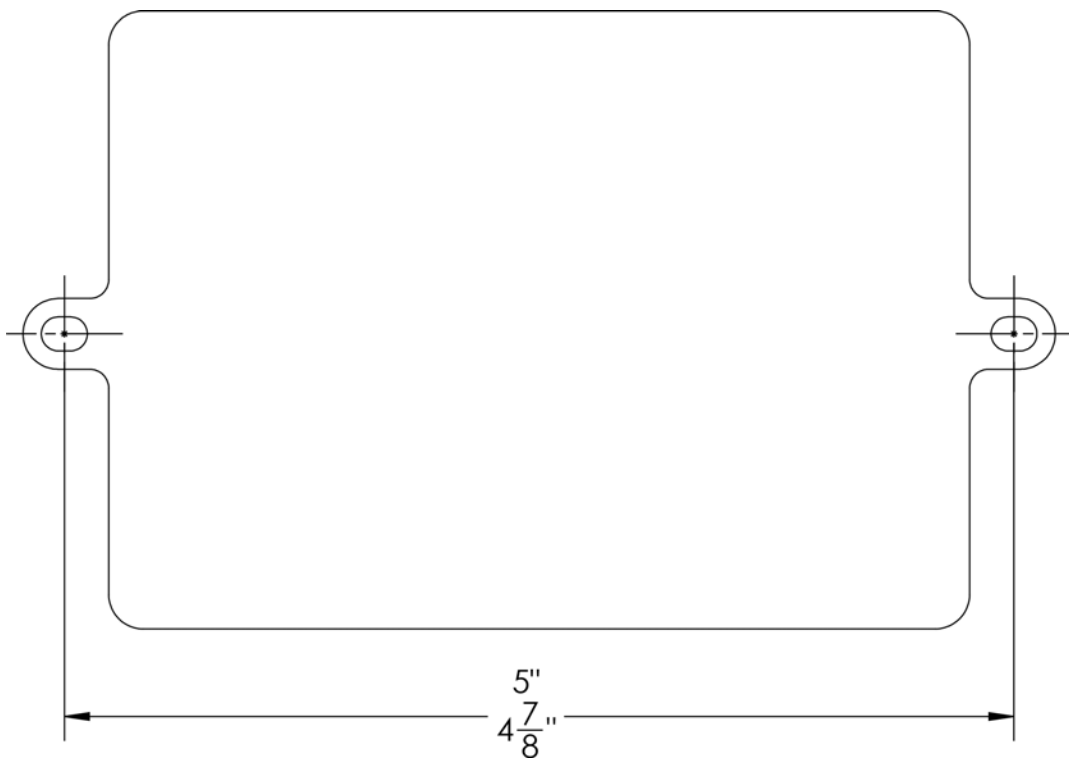

# Drill and Tap Template – Apex Series Lock

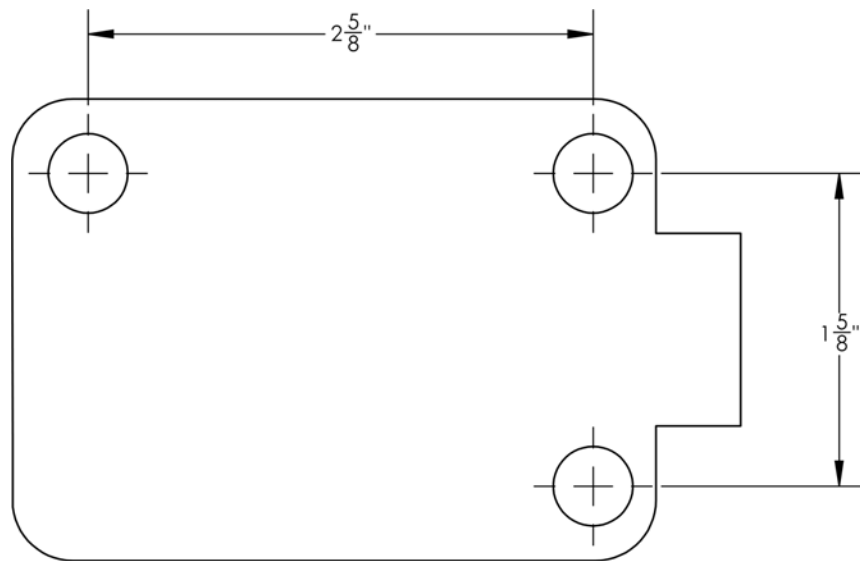

## Our Sustainability Commitment

We are committed to foster a sustainable development along our entire value chain in line with our economic, environmental and social responsibilities toward current and future generations. Sustainability at product level is an important, future-oriented approach in the field of construction. In order to give quantified disclosures of a product's environmental impact through its entire life cycle, dormakaba provides Environmental Product Declarations (EPD), based on holistic life cycle assessments.

[www.dormakaba.com/sustainability](http://www.dormakaba.com/sustainability)



## Our offering

### Access Automation Solutions

Entrance Automation  
Entrance Security



### Access Control Solutions

Electronic Access & Data  
Escape and Rescue Systems  
Lodging Systems



### Access Hardware Solutions

Door Closers  
Architectural Hardware  
Mechanical Key Systems



### Services

Technical Support  
Installation and commissioning  
Maintenance and Repair



### Key & Wall Solutions

Key Systems  
Movable / Sliding Walls



### Safe Locks

Electronic Safe Locks  
Mechanical Safe Locks  
Boltworks and Accessories



### Glass systems

Manual door systems  
Glass fittings  
Horizontal Sliding Walls



801.0622 Rev A - 02/2024  
Subject to change without notice

**dormakaba USA Inc.**  
1525 Bull Lea Road, Suite 100  
Lexington, KY 40511  
[sales.safelocks.us@dormakaba.com](mailto:sales.safelocks.us@dormakaba.com)  
T +1 800 950 4744  
+1 888 950 4715 (tech support)  
**dormakaba.com**



[dk.world/AxessorApexxIP](http://dk.world/AxessorApexxIP)