

KTV ATRIUM FLEX

All glass revolving doors



KTV ATRIUM FLEX

**Automatic, semi-automatic
and manual all-glass
revolving doors**

The design-oriented solution for
special requirement

Introduction	05
KTV ATRIUM FLEX: All-glass – simply all glass	06
Overview, functions and equipment	09
Designs and dimensions	10
Façade and building connections	12
Electrical connection	13
Safety equipment and functional elements	14

Note on product illustrations in this brochure

The product illustrations in this brochure are true representations at time of going to print.
Actual products may differ from the illustrations due to continuous development and/or local market regulations.



Welcome to transparency.

KTV ATRIUM FLEX revolving doors combine design, light and function. The exclusive all-glass design underscores the architectural references equally in a modern or historic building.

Daylight accompanies you as you enter the building, enhanced by the integrated light ring if needed.

The electromagnetic drive translates the individual functional requirements of the building into the highest level of convenience for the user. KTV ATRIUM FLEX – inviting and representative. – in line with the entire installation

KTV ATRIUM FLEX

All-glass – simply all glass

Reinventing the revolving door. The all-glass ceiling and a clearance height of up to four metres make for a breath-taking sense of transparency. The discreet direct drive in the centre of the ceiling reduces planning effort and guarantees easy installation and safe operation.

KTV ATRIUM FLEX revolving doors are up-market architectural solutions for discerning building owners.

New dimensions: Up to four metres in height and three metres in diameter

Impressively sized systems are easily implemented. We support you from the very first stages of planning. Each door system is manufactured according to your specific requirements. You can freely select the dimensions and profile surfaces. The scope of functions is configured to your needs – rotation speed, acceleration characteristics, additional safety equipment or automatic convenience features – the range of options is extensive. We work with you to find the perfect solution for your project.

01

Maximum transparency thanks to the all-glass ceiling in combination with a minimalist design featuring extra-narrow profiles

02

KT FLEX Direct drive system with LED light ring integrated in the ceiling assembly – easy to install and protected from water and dirt

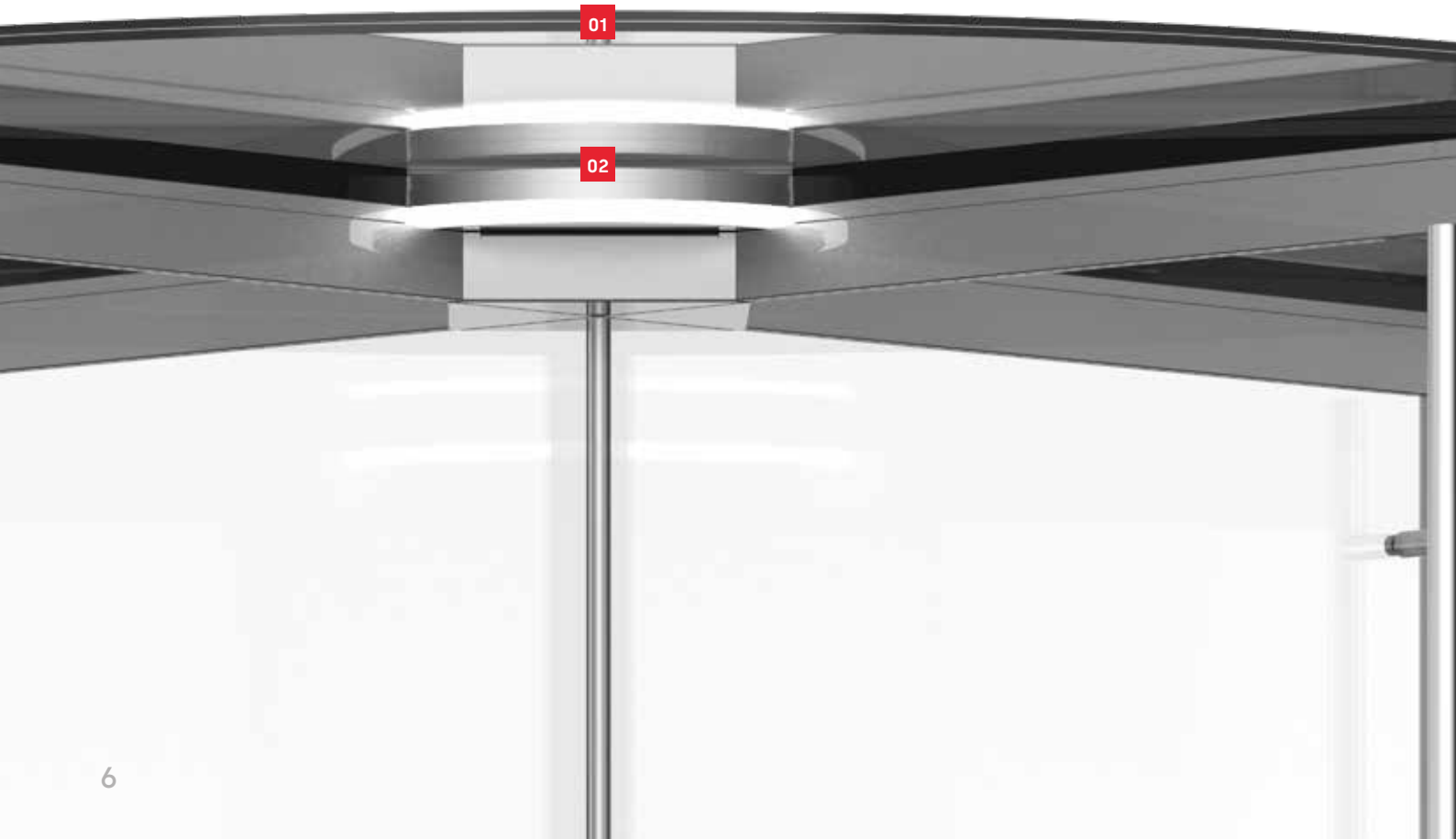

Strikingly subtle: Compact KT FLEX Direct drive system

The innovation lies within the glass ceiling. Small and protected from dirt and rainwater. System planning and construction are simplified and less costly, as there is no need for a floor pit with a complex drainage system. The electromagnetic drive works without a transmission gear, so it is extremely quiet, low-wear and low-maintenance. Depending on the operating mode, the turnstile is moved manually, power-assisted or fully automatically and its rotation speed is limited. The system controls are discreetly integrated in the design and do not require an additional control cabinet.



More detailed information and planning tips, e.g. on the subject of transit capacities, can be found in the KTV3/KTV4 technical brochure, which is available for download at www.dormakaba.com.

KT FLEX Direct drive

Safety in convenience



Configurable drive

All KTV ATRIUM FLEX revolving doors are equipped with the KT FLEX Direct drive system. The operating modes P, S or A are determined by a function module that can easily be retrofitted if the use of the door changes at a later date. The various operating modes can be supplemented with additional safety sensors and switch elements. See pages 14 and 15.

Manual, power-assisted or fully automatic?

In moderate pedestrian traffic, light and small revolving doors are easy to operate manually. The turnstile is then accelerated and guided manually. The rotation speed is limited by the drive system. Additional safety sensors are not required.

In locations with high traffic and for heavy turnstiles, the drive system can further optimise operation – from automatically starting the rotation, to fully automatic acceleration to walking speed. After each entry, the drive system automatically positions the door wings in the optimum rest position. Alternatively, the door wings can rotate continuously at check-speed.

- 01** KT FLEX Direct drive system with LED light ring
- 02** Emergency stop switch
- 03** Optional disabled button

Overview: System dimensions

Diameter	2,000–3,000 mm
Clearance height	2,100–4,000 mm
Number of door wings	3 or 4

Functions and equipment

Drive system	KT FLEX Direct			
	none	module P	module S	module A
Function module	none	module P	module S	module A
Operating mode	overspeed trip unit	automatic positioning control	servomatic	automatic
Start rotation	manual	manual	automatic	automatic
Acceleration to walking speed	manual	manual	manual	automatic
Power-assisted		●	●	
Adjustable overspeed trip unit	●	●	●	
Automatic speed control				●
Automatic positioning in rest position		●	●	●
Low-energy drive acc. to EN 16005		●	●	
Safety sensors acc. to EN 16005				●
Emergency stop switch		●	●	●
Disabled button (slow traverse)				○
Manual locking device for door wing	○	○	○	○
Air curtain system	○	○	○	○
Interface for door status signals	○	○	○	○
External interface (diagnostics and parameter setting)	●	●	●	●
Vertical push handles	●	●	●	
Vertical or horizontal cross bars	○	○	○	
Lighting	LED light ring	LED light ring	LED light ring	LED light ring
Approval certificates		EN 16005	EN 16005	EN 16005
Proven durability (cycles)	2 million	2 million	2 million	2 million

● = standard equipment ○ = optional equipment (subject to local regulations)



Individual planning service

Each door system represents an individual and integral part of the architecture. To meet these diverse challenges there are many flexible options for KTV revolving doors to meet the demands of even the most challenging installation

Designs and dimensions

Colour, anodised or stainless steel? Surface protection and finishes.

The profile and cover surfaces are available as standard powder coated to individually selectable RAL shades. Alternatively, DB or NCS shades, as well as special colours and anodised finishes in accordance with EURAS colour grades. For increased protection requirements in locations in coastal climates or areas such as swimming pools. Particularly resistant coatings can be added.

For special demands or in areas with particularly rough climate conditions, additional stainless-steel covers in satin or polished surface finishes (INOX) are also available.



Surfaces

- 01 Surface coating in accordance with RAL
- 02 Aluminium surface coating E6/C0 (EV1)
- 03 Stainless steel surface coating INOX





3 or 4-wing turnstile.Safe with floor locking device.

The turnstile can be equipped with three or four door wings. The advantage of the 3-wing door is that it provides more space in the individual segments. The lower weight also reduces the effort needed to enter manual and power-assisted doors. In addition, 3-wing doors make the clearance heights greater and brighter, which in turn allows for particularly slim door designs.

4-wing doors offer wider entrance and exit areas to facilitate simultaneous entering and exiting of the facility. With a higher number of seals toward the posts, such doors also provide better protection against draughts, noise and external climatic influences when in the rest position.

In both cases, the doors are locked against unauthorised access by means of a floor lock installed on the lower door wing section.

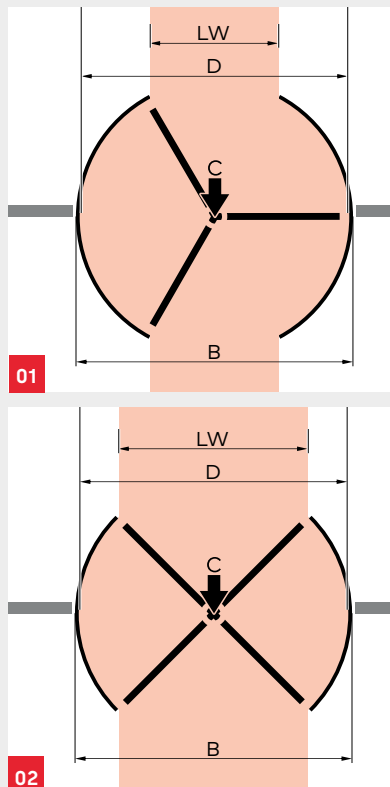

Possible Dimensions

The table shows the possible system dimensions. Any intermediate size is possible.

01 3-wing door KTV 3 ATRIUM FLEX

D	Inside diameter	2,000	2,200	2,400	2,600	2,800	3,000
B	Outside diameter	W = D + 98 mm*					
LW	Clear passage width	900	1,000	1,100	1,200	1,300	1,400
LH	Freely selectable from	2,100 to 4,000 mm					

02 4-wing door KTV 4 ATRIUM FLEX

D	Inside diameter	2,000	2,200	2,400	2,600	2,800	3,000
B	Outside diameter	W = D + 98 mm*					
LW	Clear passage width	1,331	1,472	1,614	1,755	1,896	2,038
LH	Freely selectable from	2,100 to 4,000 mm					

Minimum façade opening height $H = LH + \text{min. } 40 \text{ mm}$

Minimum façade opening width $= W + \text{min. } 80 \text{ mm}$

* With stainless steel sheeting $W = D + 102 \text{ mm}$

Façade and building connections

Each revolving door is individually planned. The connections to the building are realised in consultation with the building/façade planner. The images shown here are examples of possible designs.

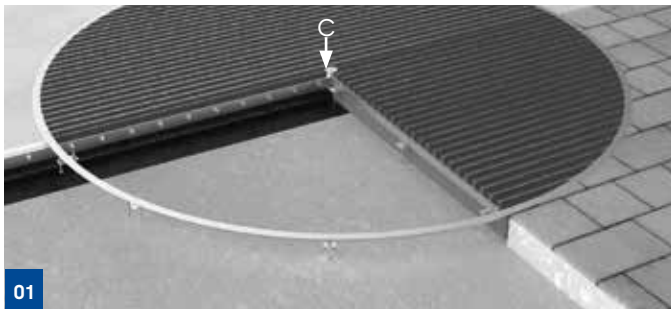

01

Design with floor ring and seal in the façade level

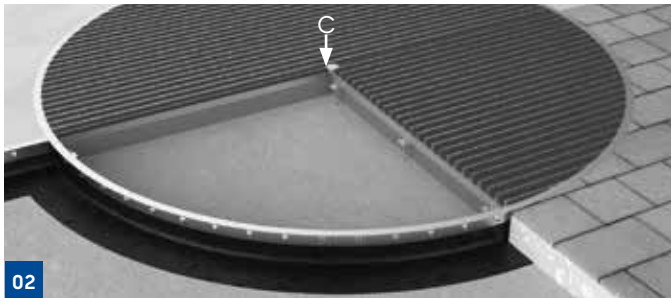

02

Design with floor ring and circumferential outside seal

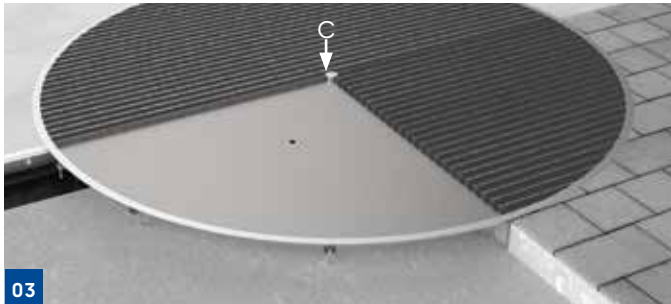

03

Design with floor ring and seal in the façade level with optional floor tray

Floor connection

In new construction projects, a stainless-steel floor ring is set in the screed, which allows for professional and precise door installation. The sophisticated fastening system makes anchoring the component in the subfloor fast and easy – without additional welding and with precise alignment to the required height level. The casting panels facilitate the professional casting of the floor rings in the screed. In addition, cleaning mats can be inserted into the floor ring as a clean run zone.

Optional extras:

- Cleaning mat with textile or rubber insert
- Clamping flange for on-site foil sealing (at centre axis **01** or circumferentially outside **02**), also in accordance with DIN 18195-5.
- Floor sheets or foil guide plates
- Stainless steel floor tray **03** with drainage connection to drain rainwater entering inside the drum during driving rains.

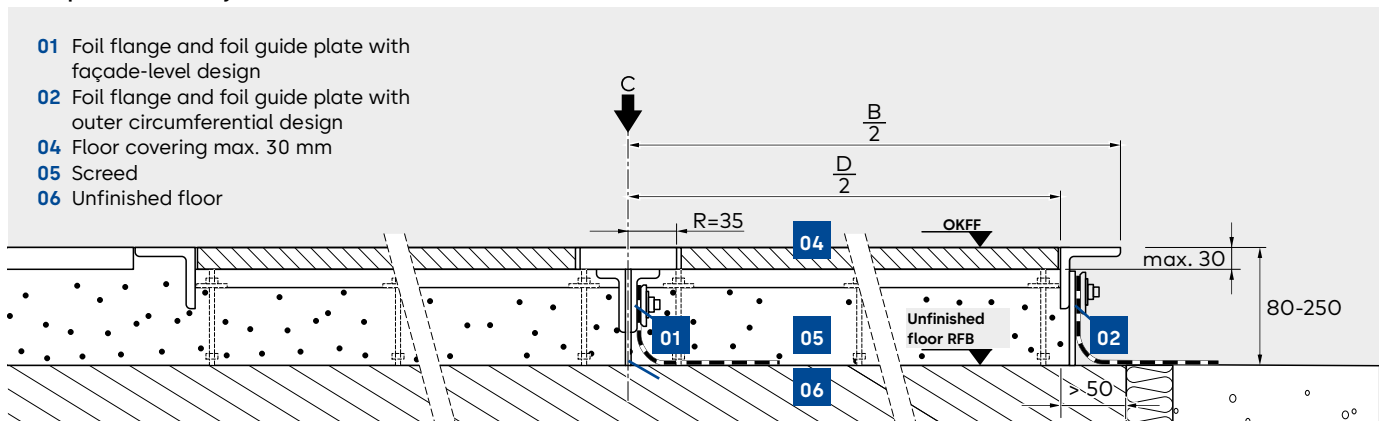

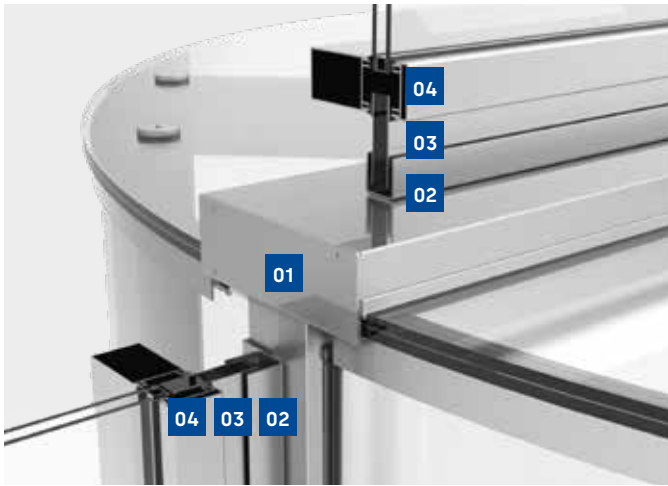

Design detail: example of a mullion-transom façade

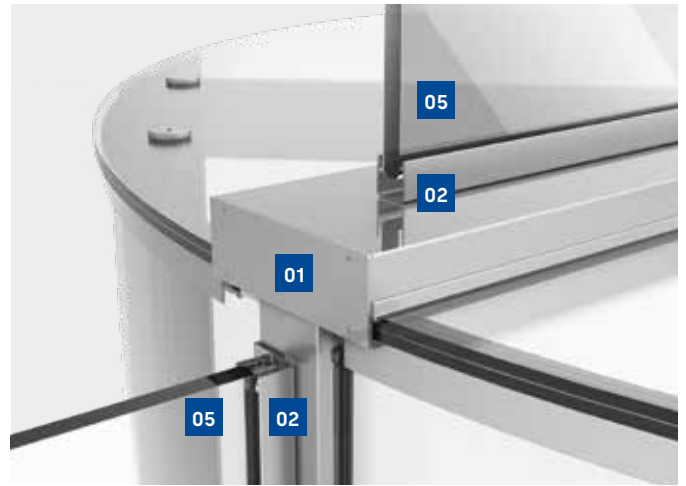

Design detail: example of an all-glass façade

Façade connection

The connection to the façade must always be coordinated with the façade planner. A wide range of solutions is available. Special attention must be paid to load transmission into the façade. With an optimised support frame, vibration can be reduced to a minimum.

The connections to the drive in the glass ceiling are established through the circumferential profile construction.

- 01** Circumferential profile construction is part of the door system and contains the connections to the drive (power supply and control)
- 02** Façade connection profiles
- 03** Sheet metal panelling or filling as defined by planner
- 04** Mullion/transom of the façade construction (on-site)
- 05** Connection glass from the façade construction (on-site)

Electrical connection

Standard connections

- 01** Power supply drive unit 3 x 1.5 mm²/220 V
- Equipotential bonding min. 6 mm²

If the system is not to be controlled from the post, the following leads must be provided on site:

- 02** Programme switch 5 x 0.75 mm²
- 03** Emergency stop switch 2 x 0.75 mm²
- 04** Disabled button
(slow traverse) 2 x 0.75 mm² (optional)

Connections for optional on-site technical building equipment

- 05** Potential-free contact
(status message) 2 x 0.75 mm² (optional)



Safety equipment and functional elements

Depending on the operating mode and function module, different safety equipment is required and additional functions are possible. With a purely manual door without a function module, no safety equipment is required, but speed limiter unit is recommended. The necessary safety equipment must be clarified individually and in advance in accordance with the national regulations.

Revolving door with KTV P positioning automatic or KTV S servomatic system
(function module P or S /low-energy mode)



Operational safety in low-energy mode

Revolving doors with positioning automatic (KTV P) or servomatic drive (KTV S) are designed as a low-energy drive system. The drive power and rotation speed are reduced. Active safety sensors are not required, the opposing closing edges on the leading mullion are secured by impact protection strips. In addition, the drive can be stopped at all times using the emergency stop switch.

		KTV P automatic positioning	KTV S servomatic
Safety equipment			
01 Impact protection strips on leading mullion	inside/outside	●	●
02 Emergency stop switch	inside	●	●
	outside	○	○
Speed limiter (adjustable)		●	●
Functional equipment			
03 Handles	Push handles (350 mm)	●	●
	Vertical/horizontal cross bars	○	○
Starting trigger	Manual push	●	-
	Movement sensor	-	●
Manual acceleration to walking speed		●	●
Program switch to select the operating mode		●	●
Locking device	manual	○	○
● = standard equipment ○ = optional equipment - = not required/not possible			

KTV-A automatic revolving door
(function module A/full-energy mode)

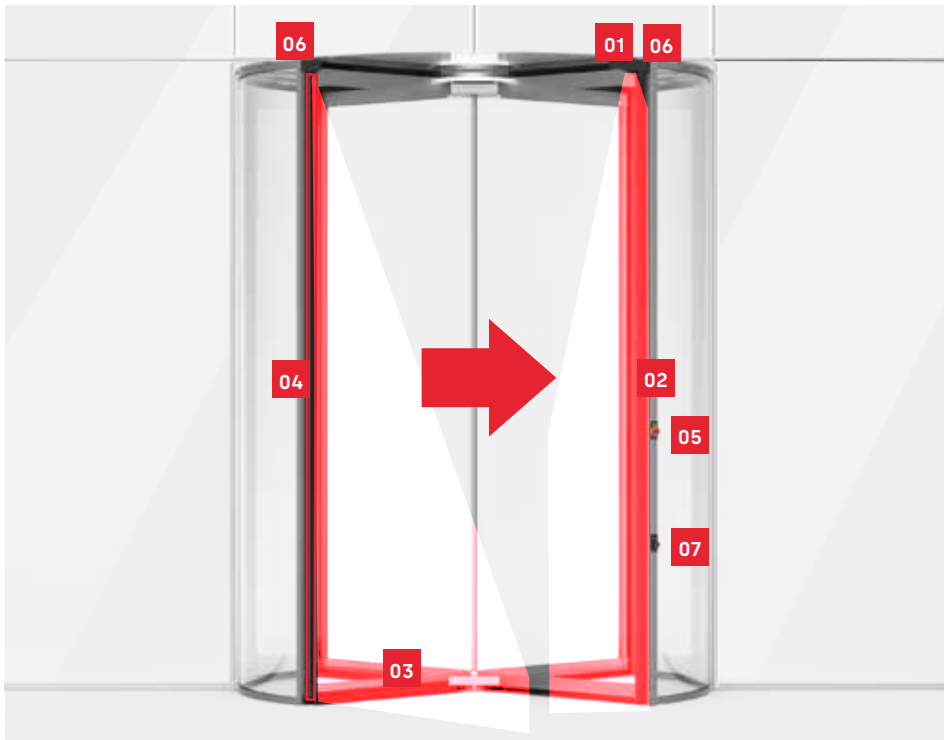

☞ Catchword emergency stop switch

When the emergency stop switch is triggered, the door stops moving immediately. It can then be manually rotated in both directions. Resetting the emergency stop switch puts the door back into the standard operating mode.

		KTV A automatic	
Safety equipment		EN 16005	Non-EU
01	Canopy sensors on leading mullion inside/outside Laser	●	●
02	Safety bumpers on leading mullion inside/outside Impact protection strips	●	
			●
03	Safety contact strips on wings horizontal, lower edge	●	●
04	Safety contact strips on wings, vertical, outer edge	●	
05	Emergency stop switch inside	●	●
		○	○
Functional equipment			
06	Internal/external movement sensors	●	●
07	Disabled button (slow rotation) inside/outside	○	○
	Program switch to select the operating mode	●	●
	Locking device manual	○	○

● = standard equipment ○ = optional equipment (subject to local regulations)

Operational safety in full-energy mode

The revolving door is automatically operated and, if necessary, slowed down or stopped. Depending on the size of the system and the requirements to be fulfilled, various actuating and safety devices are used with the system:

- Movement sensors, start buttons, card readers
- Disabled buttons, emergency stop switch
- Active safety contact strips, passive impact protection strips
- Canopysafety sensors on the opposing closing edges (posts)

Our Sustainability Commitment

We are committed to foster a sustainable development along our entire value chain in line with our economic, environmental and social responsibilities toward current and future generations. Sustainability at product level is an important, future-oriented approach in the field of construction. In order to give quantified disclosures of a product's environmental impact through its entire life cycle, dormakaba provides Environmental Product Declarations (EPD), based on holistic life cycle assessments.

www.dormakaba.com/sustainability



Our offering

Access Automation Solutions

Entrance Automation
Entrance Security



Access Control Solutions

Electronic Access & Data
Escape and Rescue Systems
Lodging Systems



Access Hardware Solutions

Door Closers
Architectural Hardware
Mechanical Key Systems



Services

Technical Support
Installation and commissioning
Maintenance and Repair



WN 05344651532, EN, 10/2023
Subject to change without notice



dormakaba.com

dormakaba
International Holding AG
Hofwissenstrasse 24
CH-8153 Rümlang
T +41 44 818 90 11
info@dormakaba.com
dormakaba.com